

LM Guide HSR – Four-Way Equal-Load Type

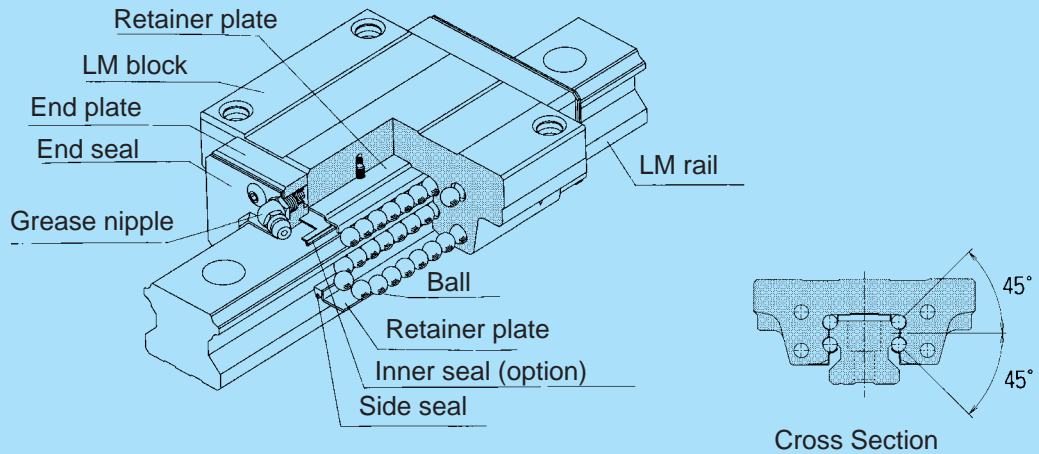

Fig. 1 Construction of Model NRS

Construction and Features

Balls roll in four rows of a precisely-ground raceway on an LM rail and an LM block. The end plate attached to the LM block causes the trains of balls to circulate.

As the balls are held in place by the retainer plate, they do not fall off if the LM block is removed from the rail (except for types HSR 8, 10, and 12).

The four trains of balls are arranged so that the contact angle is 45°, allowing each train of balls to bear an equal rated load in all four directions: radial, reverse-radial, and the two lateral directions. This type can therefore be used in any installation direction. Moreover, HSR enables the application of a well-balanced preload, making it possible to increase rigidity in the four directions while maintaining a low friction coefficient. The low-profile design and use of high-rigidity LM blocks provide stable, highly accurate linear motion.

Four-way equal load

The raceways are arranged at 45° in relation one another, so that each train of balls bears an equal rated load in all four directions: radial, reverse-radial, and the two lateral directions. This type can therefore be used in any installation directions and boasts a wide range of uses.

High rigidity

The excellent balance among the four rows of raceways enables the application of a sufficient preload, providing the LM Guide with a high degree of rigidity and freeing it from undesired strain. Moreover, due to the strength of the mounting bolts and LM block used, type HSR is in use in a wide range of heavy-cutting machine tools.

Self-adjusting capability

Self-adjustment is performed automatically due to the circular-arc groove design (face-to-face DF). Installation errors can therefore be compensated for, even under a preload, resulting in highly precise and smooth linear motion.

High durability

Even under a preload or uneven load, no differential sliding occurs to the balls, thereby enabling smooth ball rolling. Wear is thus limited, and long-term precision is ensured.

Stainless steel type available

Upon request, we can provide stainless steel LM blocks, rails, and balls.

Types and Features

Standard heavy-load types

Type HSR-A

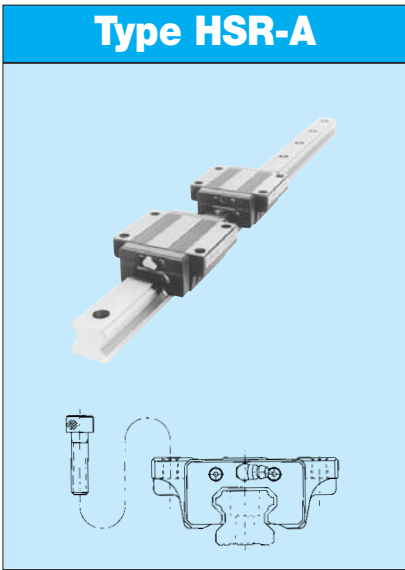

The flange of the LM block is provided with tapped holes to enable simple assembly, making it suitable for use in build-up systems.
Four-bolt type

Type HSR-B

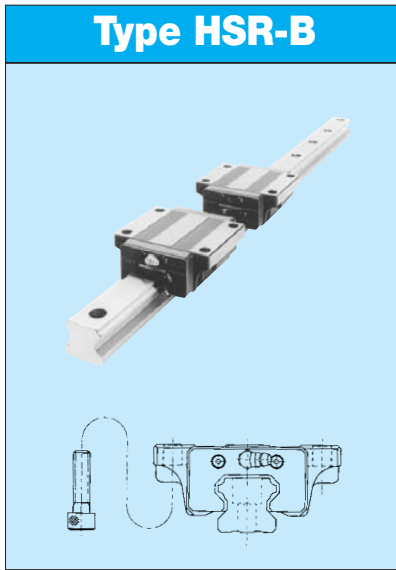

The LM blocks can be attached to a table from below. For use with a table in which a through hole cannot be drilled.
Four-bolt type

Type HSR-R

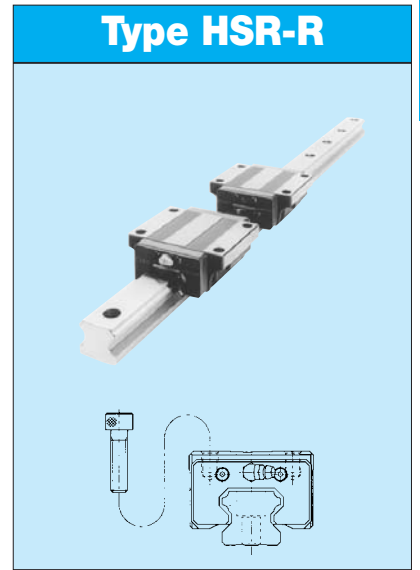

The narrowed flange of the LM block is provided with tapped holes, making it convenient for use in build-up systems. Can be used to replace the former type NSR-TBA.
Four-bolt type

Standard ultra-heavy-load types

Type HSR-LA

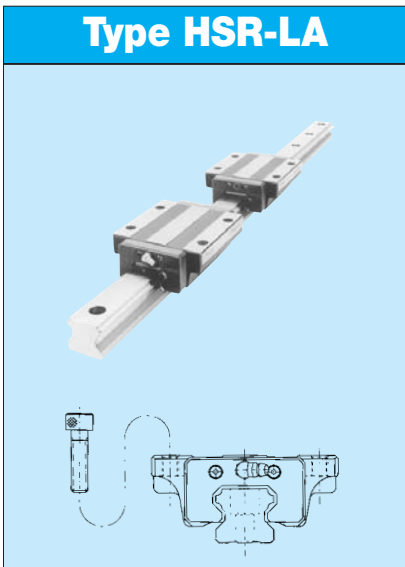

While the cross-sectional dimensions are the same as for type HSR-A, the LM block is longer. The number of effective balls is greater than in type HSR-A.
Four-bolt type

Type HSR-LB

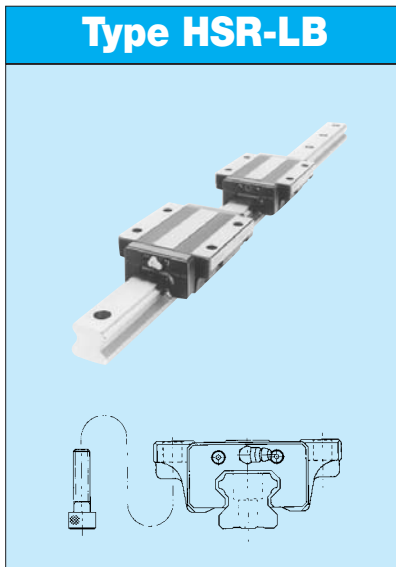

While the cross-sectional dimensions are the same as for type HSR-B, the LM block is longer. The number of effective balls is greater than in type HSR-B.
Four-bolt type

Type HSR-LR

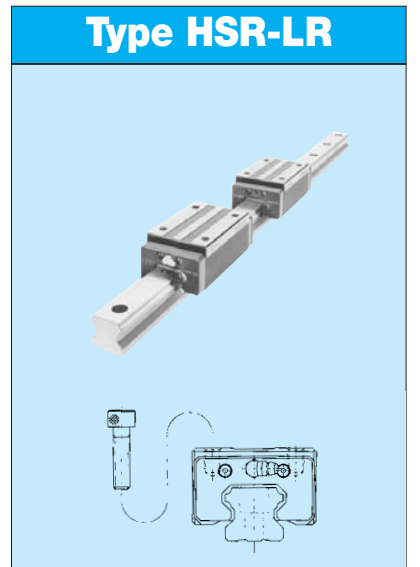

While the cross-sectional dimensions are the same as for type HSR-R, the LM block is longer. The number of effective balls is greater than in type HSR-R.
Four-bolt type

Miniature four-way equal-load type

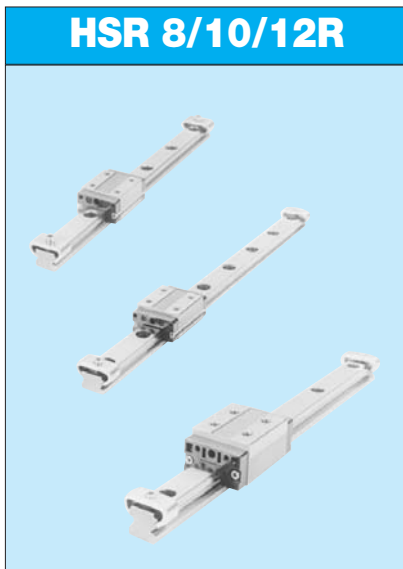

This series features the smallest LM Guide models. As the LM block is slim, it must be fastened in place using the tapped holes provided on the top surface.

Heavy-duty four-way equal-load type



Can be used for large machine tools and even buildings

Load rating

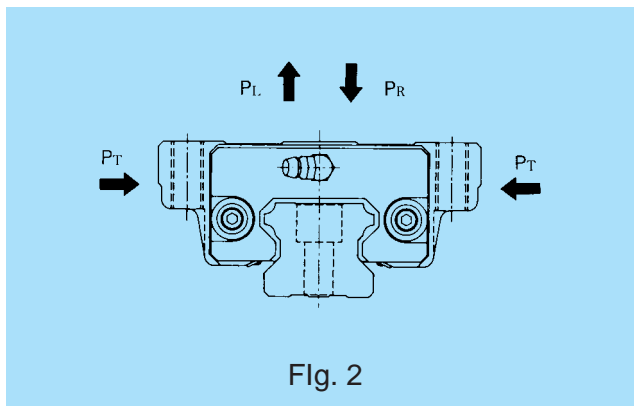

Fig. 2

Type HSR can bear loads in all four directions: radial, reverse-radial, and two lateral directions.

The basic load ratings of HSR are equivalent to one another in all four directions (radial, reverse-radial and two lateral directions). The values are presented in the corresponding dimension tables.

Equivalent load

An equivalent load for type HSR when loads in all four directions are exerted on its LM block simultaneously can be obtained using the following equation:

$$P_E = P_R (P_L) + P_T$$

where

P_E : equivalent load (N)

- In the radial direction
- In the reverse-radial direction
- In the lateral direction

P_R : radial load (N)

P_L : reverse-radial load (N)

P_T : lateral load (N)

Permissible moment

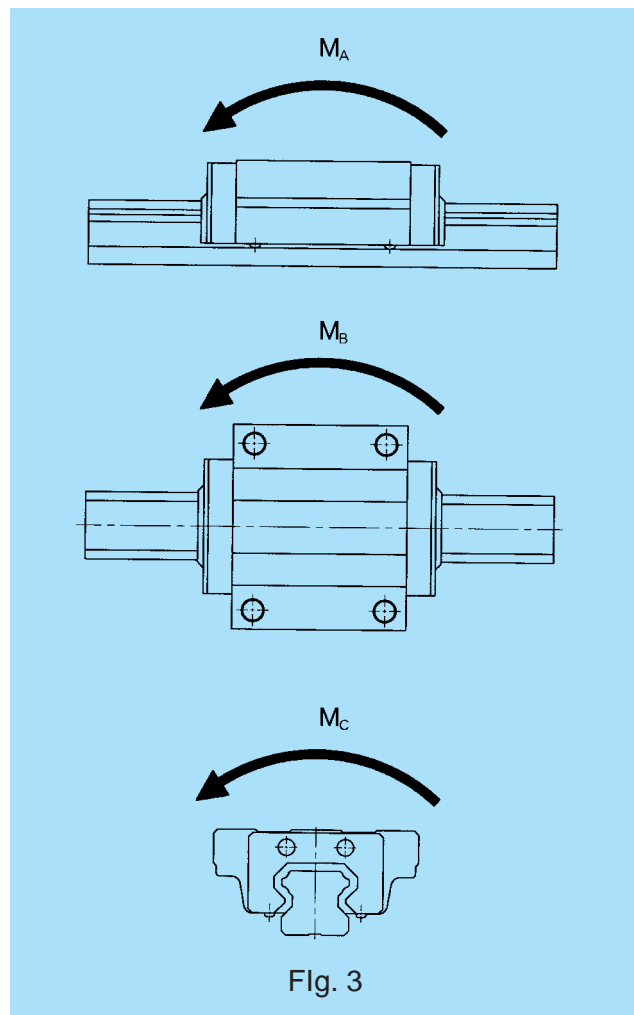

Fig. 3

In type HSR, a single LM block can bear moments in all directions. Table 1 presents the permissible moments in directions M_A , M_B , and M_C for a single LM block and two LM blocks laid over one another (no data for direction M_C).

Table 1 Type-HSR Static Permissible Moment

Unit : kNm

Clearance symbol Model No.	M_A		M_B		M_C
	Single block	Double block	Single block	Double block	Single block
HSR 8	0.0039	0.026	0.0039	0.026	0.0088
HSR 10	0.0098	0.062	0.0098	0.062	0.0196
HSR 12	0.0333	0.20	0.0333	0.20	0.052
HSR 15	0.07	0.37	0.07	0.37	0.10
HSR 20	0.16	0.82	0.16	0.82	0.23
HSR 20 L	0.27	1.4	0.27	1.4	0.31
HSR 25	0.27	1.4	0.27	1.4	0.4
HSR 25 L	0.46	2.4	0.46	2.4	0.51
HSR 30	0.43	2.3	0.43	2.3	0.65
HSR 30 L	0.73	3.7	0.73	3.7	0.86
HSR 35	0.64	3.4	0.64	3.4	1.0
HSR 35 L	1.1	5.6	1.1	5.6	1.4
HSR 45	1.3	6.9	1.3	6.9	2.1
HSR 45 L	2.1	10.9	2.1	10.9	2.8
HSR 55	2.2	11.7	2.2	11.7	3.6
HSR 55 L	3.7	18.8	3.7	18.8	4.8
HSR 65	4.2	21.0	4.2	21.0	6.6
HSR 65 L	7.2	35.8	7.2	35.8	8.9
HSR 85	10.2	56.5	10.2	56.5	12.6
HSR 85 L	12.4	63.5	12.4	63.5	16.7
HSR 100	16.9	86.1	16.9	86.1	25.3
HSR 120	22.5	113.5	22.5	113.5	34.8
HSR 150	29.2	146.9	29.2	146.9	52.4

Accuracy Standards

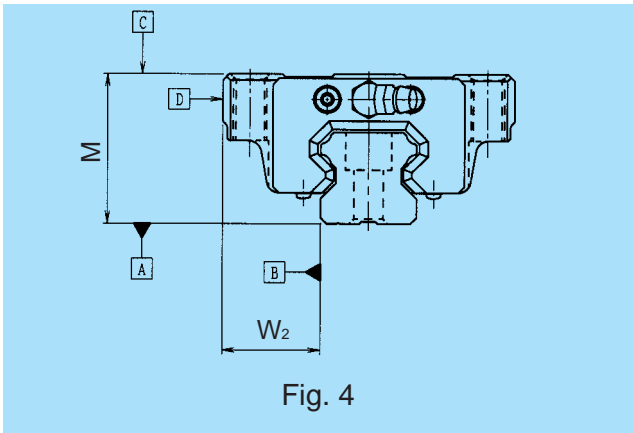

Fig. 4

The accuracy of type HSR is divided into five grades, normal, high, precision, super-precision, and ultra-precision, in accordance with the model numbers shown in Table 2.

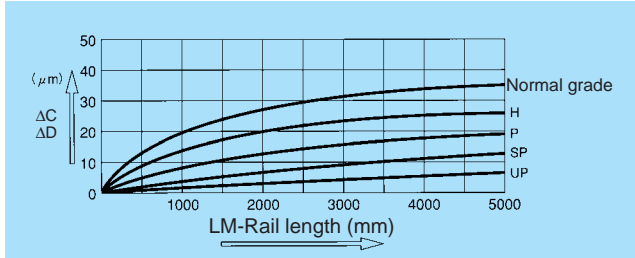

Fig. 5 Relationship Between LM-Rail Length and Running Parallelism

Table 2 Type HSR Accuracy Standard

Unit : mm

Model No.	Accuracy standard	Normal	High	Precision	Super-precision	Ultra-precision
	Item	No symbol	H	P	SP	UP
HSR 8 HSR 10 HSR 12	Tolerance for height M	±0.08	±0.04	±0.02	±0.01	—
	Tolerance for the height M difference among LM blocks	0.015	0.007	0.005	0.003	—
	Tolerance for rail-to-block lateral distance W_2	±0.05	±0.025	±0.015	±0.010	—
	Tolerance for rail-to-block lateral distance W_2 difference among LM blocks	0.02	0.01	0.007	0.005	—
	Running Parallelism of surface C with surface A	C (as per Fig. 5)				
	Running parallelism of surface D with surface B	D (as per Fig. 5)				
HSR 15 HSR 20	Tolerance for height M	±0.1	±0.03	0 -0.03	0 -0.015	0 -0.008
	Tolerance for the height M difference among LM blocks	0.02	0.01	0.006	0.004	0.003
	Tolerance for rail-to-block lateral distance W_2	±0.1	±0.03	0 -0.03	0 -0.015	0 -0.008
	Tolerance for rail-to-block lateral distance W_2 difference among LM blocks	0.02	0.01	0.006	0.004	0.003
	Running Parallelism of surface C with surface A	C (as per Fig. 5)				
	Running parallelism of surface D with surface B	D (as per Fig. 5)				
HSR 25 HSR 30 HSR 35	Tolerance for height M	±0.1	±0.04	0 -0.04	0 -0.02	0 -0.01
	Tolerance for the height M difference among LM blocks	0.02	0.015	0.007	0.005	0.003
	Tolerance for rail-to-block lateral distance W_2	±0.1	±0.04	0 -0.04	0 -0.02	0 -0.01
	Tolerance for rail-to-block lateral distance W_2 difference among LM blocks	0.03	0.015	0.007	0.005	0.003
	Running Parallelism of surface C with surface A	C (as per Fig. 5)				
	Running parallelism of surface D with surface B	D (as per Fig. 5)				
HSR 45 HSR 55	Tolerance for height M	±0.1	±0.05	0 -0.05	0 -0.03	0 -0.02
	Tolerance for the height M difference among LM blocks	0.03	0.015	0.007	0.005	0.003
	Tolerance for rail-to-block lateral distance W_2	±0.1	±0.05	0 -0.05	0 -0.03	0 -0.02
	Tolerance for rail-to-block lateral distance W_2 difference among LM blocks	0.03	0.02	0.01	0.007	0.005
	Running Parallelism of surface C with surface A	C (as per Fig. 5)				
	Running parallelism of surface D with surface B	D (as per Fig. 5)				
HSR 65 HSR 85 HSR100 HSR120 HSR150	Tolerance for height M	±0.1	±0.07	0 -0.07	0 -0.05	0 -0.03
	Tolerance for the height M difference among LM blocks	0.03	0.02	0.01	0.007	0.005
	Tolerance for rail-to-block lateral distance W_2	±0.1	±0.07	0 -0.07	0 -0.05	0 -0.03
	Tolerance for rail-to-block lateral distance W_2 difference among LM blocks	0.03	0.025	0.015	0.010	0.007
	Running Parallelism of surface C with surface A	C (as per Fig. 5)				
	Running parallelism of surface D with surface B	D (as per Fig. 5)				

Radial clearance

Table 3 presents the radial clearances of types HSR.

Table 3 Type-HSR Radial Clearances

Unit : μm

Model No.	Clearance symbol	Normal	Under a light preload	Medium preload
	No symbol		C1	C0
HSR 8		± 1	- 4 ~ - 1	—
HSR 10		± 2	- 5 ~ - 1	—
HSR 12		± 3	- 6 ~ - 2	—
HSR 15		- 4 ~ + 2	- 12 ~ - 4	—
HSR 20		- 5 ~ + 2	- 14 ~ - 5	- 23 ~ - 14
HSR 25		- 6 ~ + 3	- 16 ~ - 6	- 26 ~ - 16
HSR 30		- 7 ~ + 4	- 19 ~ - 7	- 31 ~ - 19
HSR 35		- 8 ~ + 4	- 22 ~ - 8	- 35 ~ - 22
HSR 45		- 10 ~ + 5	- 25 ~ - 10	- 40 ~ - 25
HSR 55		- 12 ~ + 5	- 29 ~ - 12	- 46 ~ - 29
HSR 65		- 14 ~ + 7	- 32 ~ - 14	- 50 ~ - 32
HSR 85		- 16 ~ + 8	- 36 ~ - 16	- 56 ~ - 36
HSR100		- 19 ~ + 9	- 42 ~ - 19	- 65 ~ - 42
HSR120		- 21 ~ + 10	- 47 ~ - 21	- 73 ~ - 47
HSR150		- 23 ~ + 11	- 51 ~ - 23	- 79 ~ - 51

Model-number coding

HSR25 A 2 UU C0 M + 1200L P M - II

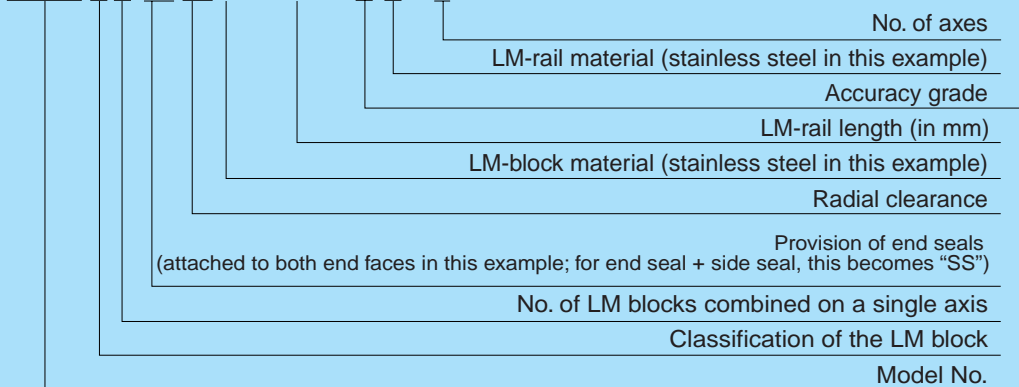

Note: This coding is based on the assumption of one set of code for a one-axis unit.
(A configuration of two axes installed in parallel is given at least two sets of code.)

Contamination Protection

Types HSR is provided with end and side seals as standard contamination-protection accessories.

End seal

Standard accessory

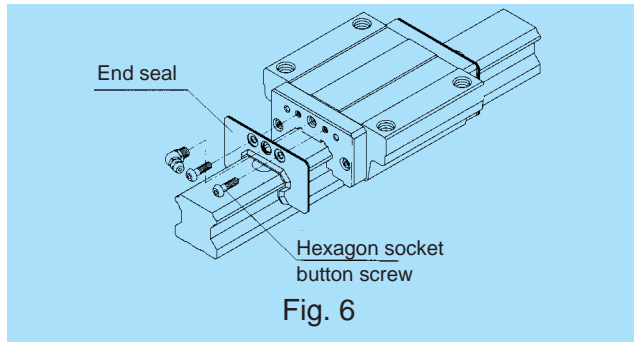

Double seal

Use two end seals to enhance the contamination-protection capacity

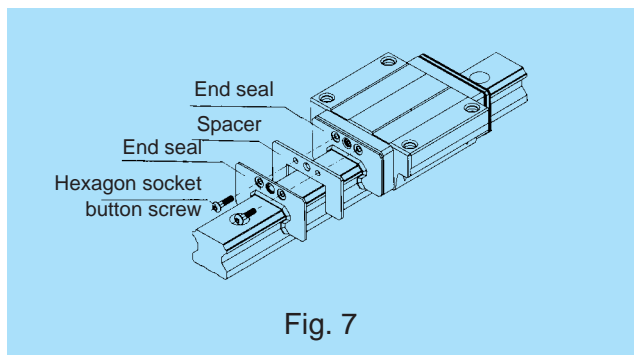

Scraper

Removes spatters and similar large foreign matter

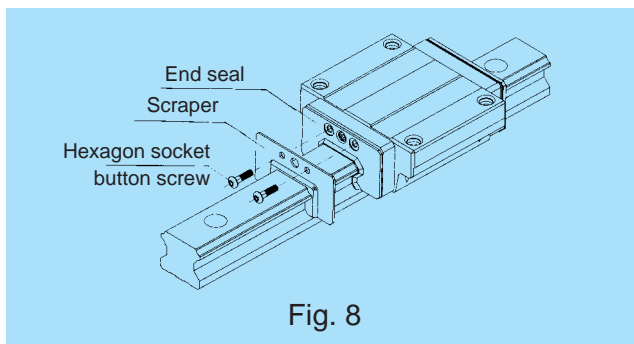

Side seal

Prevents contaminants from entering an LM block from below

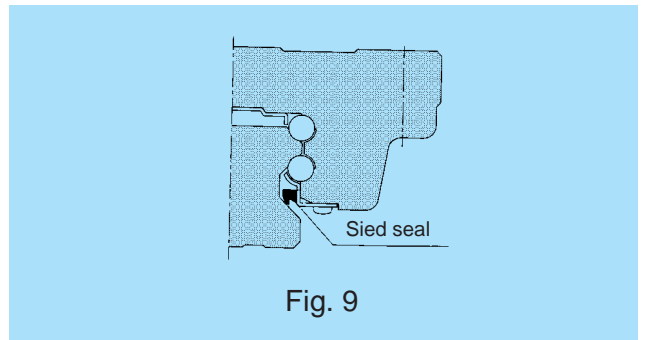

Inner seal

Installed in a LM block

Applicable model Nos.: HSR 30/35/45/55/65/85

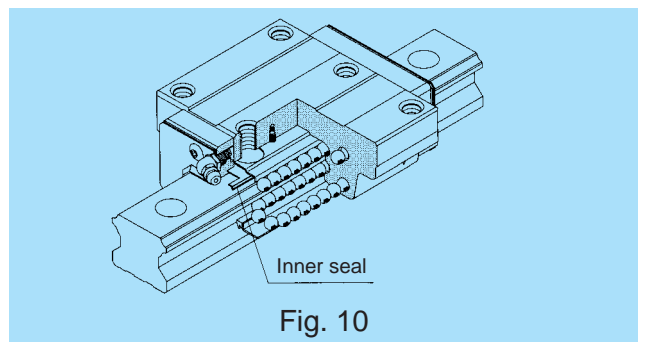

Contamination-protection-accessory symbol

Where a contamination-protection accessory is required, specify so using the symbols shown below.

Some models do not accept contamination-protection accessories. Confirm which parts are applicable by referring to Table 4.

Attaching a contamination-protection accessory to an LM block changes the block overall length. Add to dimension L the increment specified in the corresponding dimension table.

Contamination-protection accessory	Symbol
End seal (on both end faces)	UU
End seal + side seal	SS
End seal + side seal + scraper	ZZ
Double seals + side seal	DD
Double seals + side seal + scraper	KK
End seals (low seal resistance)	LL
LL seal + side seal	RR

Table 4 Applicability of Seals to Type HSR, and the Increment to Be Added to the Block Overall Length

Unit : mm

Model. No.	No symbol		UU		SS		DD		ZZ		KK		LL		RR	
	O	-	O	-	O	-	O	-	O	-	O	-	O	-	O	-
HSR 8	O	- 3.0	O	-	×		×		×		×		×		×	
HSR 10	O	- 3.0	O	-	×		×		×		×		×		×	
HSR 12	O	- 3.0	O	-	×		×		×		×		×		×	
HSR 15	O	- 5.0	O	-	O	-	O	5.2	△	1.6	△	6.8	O	-	O	-
HSR 20	O	- 6.0	O	-	O	-	O	6.6	O	2.6	O	9.2	O	-	O	-
HSR 25	O	- 7.0	O	-	O	-	O	7.6	O	2.6	O	10.2	O	-	O	-
HSR 30	O	- 7.0	O	-	O	-	O	7.6	O	2.6	O	10.2	O	-	O	-
HSR 35	O	- 7.0	O	-	O	-	O	7.6	O	2.6	O	10.2	O	-	O	-
HSR 45	O	- 7.0	O	-	O	-	O	7.2	O	5.2	O	12.4	O	-	O	-
HSR 55	O	- 7.0	O	-	O	-	O	7.2	O	5.2	O	12.4	O	-	O	-
HSR 65	O	- 7.0	O	-	O	-	O	7.2	O	5.2	O	12.4	O	-	O	-
HSR 85	O	- 7.0	O	-	O	-	O	7.2	O	4.8	O	12.0	×		×	
HSR 100	O	-12.0	O	-	O	-	×		×		×		×		×	
HSR 120	O	-12.0	O	-	O	-	×		×		×		×		×	
HSR 150	O	-12.0	O	-	O	-	×		×		×		×		×	

Note: O = Applicable

× = Inapplicable

△ = Applicable, but a grease nipple cannot be attached; contact us

Semi-standard greasing hole

For type HSR, a greasing hole is semi-standard. When placing an order, specify the application of the hole required.

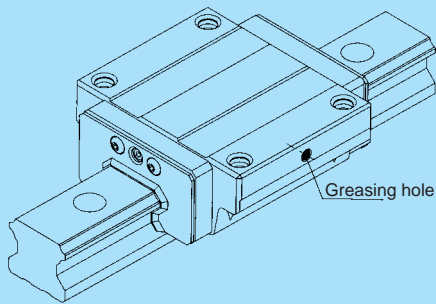

Greasing
Side-Hole Specifications

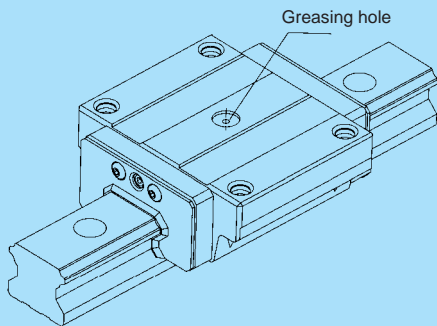

Greasing
Top-Hole Specifications

Fig. 11

For details, contact us.

Seal resistance value

For the maximum value of seal resistance of seals type HSR...UU per LM block in which grease is applied, see Table 5.

Table 5 Maximum Resistance Value
of seals to Type HSR

Unit : N

Model No.	Seal resistance value
HSR 8	0.5
HSR 10	0.8
HSR 12	1.2
HSR 15	2.0
HSR 20	2.5
HSR 25	3.9
HSR 30	7.8
HSR 35	11.8
HSR 45	19.6
HSR 55	19.6
HSR 65	34.3
HSR 85	34.3
HSR 100	-
HSR 120	-
HSR 150	-

Dedicated Bellows JH for LM-Guide Type HSR

Shown below are the dimensions of dedicated bellows JH for type HSR. When ordering the bellows, specify the relevant model number shown in the table below.

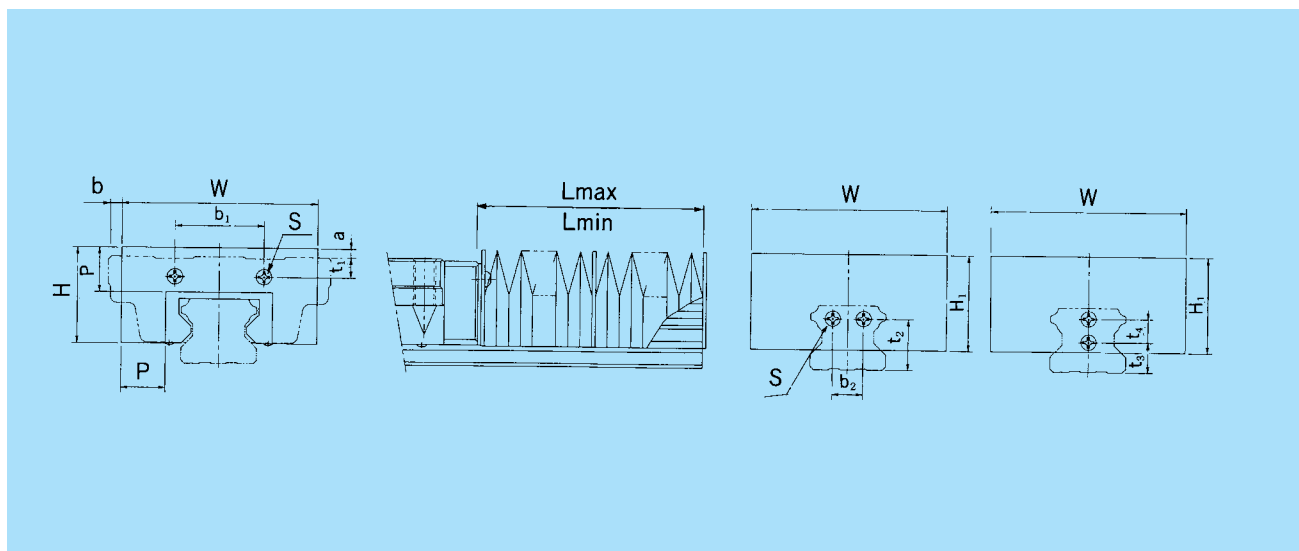

Unit : mm

Model No.	Boundary dimensions												Mounting bolt S	a				b		A ($\frac{L_{max}}{L_{min}}$)	Applicable LM-Guide model
	W	H	H ₁	P	b ₁	A/B type	t ₁	R type	b ₂	t ₂	t ₃	t ₄		A/B type	R type	A/B type	R type				
JH15	55	27	30	15	25	2.5	6.5	-	-	10	-	M4×8	7.5	3.5	-4	-10.5	5	HSR15			
JH20	66	32	35	17	34	5	5	-	-	6	8	M3×0.5×6	7	7	-1.5	-11	6	HSR20			
JH25	78	38	38	20	30	7	11	-	-	10	8	M3×0.5×6	8.5	4.5	-4	-15	7	HSR25			
JH30	84	42	42	20	40	8	11	-	-	11	10	M4×0.7×8	7	4	3	-12	7	HSR30			
JH35	88	43	43	20	40	9	16	14	23	-	-	M4×0.7×8	4	-	6	-9	7	HSR35			
JH45	100	51	51	20	58	10	20	20	29	-	-	M5×0.8×10	-	-	10	-7	7	HSR45			
JH55	108	54	54	20	66	11	21	26	35	-	-	M5×0.8×10	-	-	16	-4	7	HSR55			
JH65	132	68	68	20	80	19	19	32	42	-	-	M6×12	-	-	19	-3	7	HSR65			
JH85	170	88	88	30	105	23	23	44	50	-	-	M6×12	-	-	22.5	-7	10	HSR85			

Notes:

1. Mounting bolts marked with a "*" for model JH15 are provided on the LM-rail side only. On the LM block, tapping screws of nominal size at "2x5" are used.
2. In installation positions other than horizontal (e.g., vertical and wall-hung), the expansion ratios differ from those given in this table (guideline: A-1.5). When placing an order, specify your installation direction.
3. If bellows are attached to both ends of an LM block, a grease nipple cannot be installed there. In such a case, contact us.

Model-number coding

JH25 - 60/420

Bellows dimensions $\frac{\text{length when compressed}}{\text{length when expanded}}$

Model No. (bellows for type HSR25 in this example)

Note: A bellows length can be calculated as shown below.

$$L_{min} = \frac{S}{(A - 1)} \quad S: \text{stroke length in (mm)}$$

$$L_{max} = L_{min} \cdot A \quad A: \text{expansion ratio}$$

DH Bellows Designed for Type HSR

For types HSR15, HSR20, and HSR25, a bellows-type DH with the features specified below is available. When placing an order, specify model numbers, which are shown below.

Features

q The width and height are smaller than those of conventional bellows. As a result, type DS does not protrude over the top surface of an LM block. The expansion ratio is equal to or greater than that of a conventional bellows.

- w Each ridge of the bellows has a partition plate to prevent the bellows from lifting. As a result, type DS can be used in the vertical, wall-hung, and tilted positions.
- e Excellent high-speed operation, up to as high as 120 m/min.
- r Can be equipped with Velcro, enabling use at any desired length, either by cutting a regular-length product into short sections or by joining more multiple pieces using an adhesive.
- t As with conventional types, type DS can also be fastened using screws. When doing so, hold the plate (1.6 mm in thickness) between the LM block and the bellows.

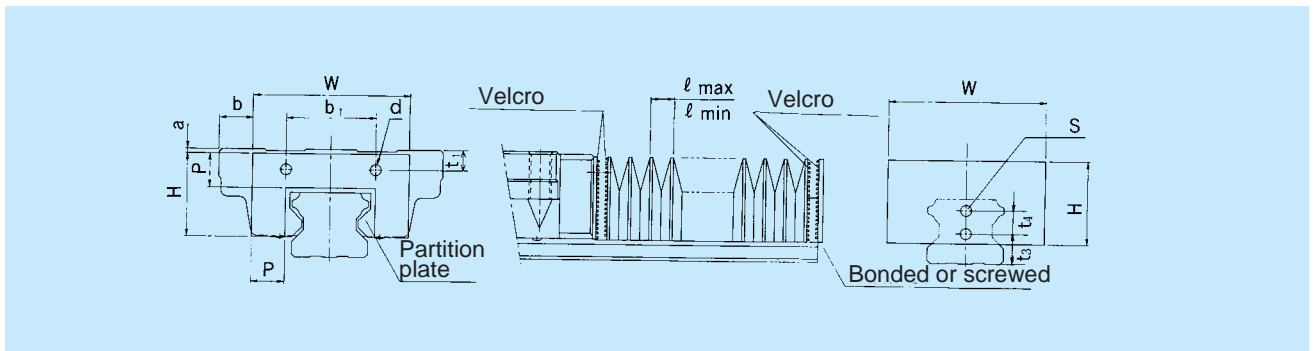

Unit : mm

Model No.	Boundary dimensions																		Applicable LM-Guide model
	W	H	P	b ₁	A/B type	t ₁ R type	t ₃	t ₄	d	A/B type	R type	A/B type	R type	ℓ _{max}	ℓ _{min}	Expansion ratio	A	E	
DH15	35	19.5	8.5	25	2.5	6.5	10	-	3.5	0	4	6	-0.5	10	2.5	4	2	1.2	HSR15
DH20	45	25	10	34	5	5	6	8	4	0	0	9	-0.5	13	2.5	5	2	1.3	HSR20
DH25	52	29.5	12	30	7	11	10	8	4	0	4	9	-2	15	3	5	2	1.3	HSR25

Note : If bellows are attached to both ends of an LM block, a grease nipple cannot be installed there. In such a case, contact us.

Model-number coding

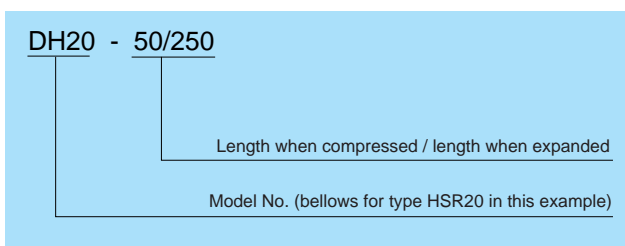

- Max length (Standard length) as a single piece is

$$L_{\min} = \frac{\ell_s}{(A - 1)} = \frac{530}{4} = 132.5 \approx 135$$

$$L_{\max} = A \cdot L_{\min} = 5 \times 135 = 675$$

Hence, the number of crests required is as follows:

$$n = \frac{L_{\max}}{P \cdot k} = \frac{675}{10 \times 1.3} = 51.9 \approx 52$$

$$L_{\max} (L_{\min}) = \ell_{\max} (\ell_{\min}) \times 200$$

(E = plate thickness; 2 in the present example)

Thus, the bellows to be used are DH20-132/675.

LM Cover TPH Designed for Type HSR

The dimensions of type-HSR-dedicated LM cover type TPH are as shown below. When placing an order,

specify by the following model numbers.

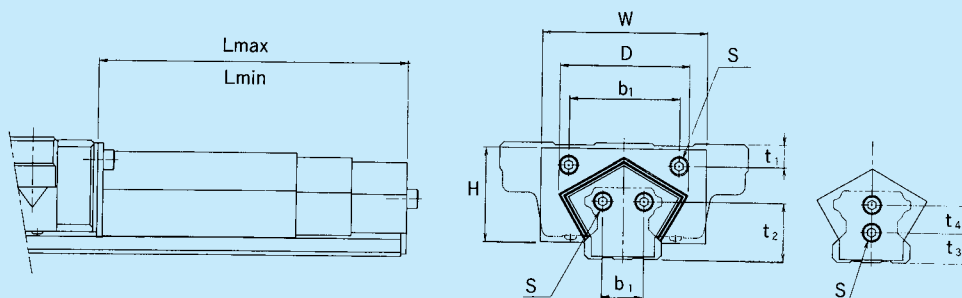

Unit : mm

Model No.	Boundary dimensions										Applicable LM-Guide model
	W	D (max)	H	b ₁	t ₁	b ₂	t ₂	t ₃	t ₄	Mounting bolt	
TPH 25	55	42	28	30	7	-	-	10	8	M3 × 0.5 × 6	HSR 25
TPH 30	60	48	34	40	8	-	-	11	10	M4 × 0.7 × 8	HSR 30
TPH 35	70	55	38	40	9	14	23	-	-	M4 × 0.7 × 8	HSR 35
TPH 45	90	75	48	58	10	20	29	-	-	M5 × 0.8 × 10	HSR 45
TPH 55	100	88	55	66	11	26	35	-	-	M5 × 0.8 × 10	HSR 55

Unit : mm

Model No.	No. of sectors	L		Stroke
		min	max	
TPH 25	3	200	530	330
	3	150	380	230
	3	100	230	130
TPH 30	3	250	680	430
	3	200	530	330
TPH 35	3	300	830	530
	3	250	680	430
	3	200	530	330
	3	150	380	230

Unit : mm

Model No.	No. of sectors	L		Stroke
		min	max	
TPH 45	3	350	980	630
	3	300	830	530
	3	250	680	430
	3	200	530	330
TPH 55	4	400	1460	1060
	4	350	1330	980
	4	300	1060	760
	4	250	860	610

Model-number coding

TPH55 - 400/1460

Lmax (cover length when expanded)

Lmin (cover length when compressed)

Model number (for HSR55)

Note : If bellows are attached to both ends of an LM block, a grease nipple cannot be installed there. In such a case, contact us.

Precautions on Use

Mounting-Surface Height and Corner Profile

Normally, mounting surfaces for LM blocks and rails have lateral reference surfaces to aid in positioning rails and blocks with a high degree of accuracy.

For the reference-surface shoulder height, see Table 6.

Furthermore, provide enough space to the corner profile of a mounting surface so that the corner does not interfere with chamfers made on the LM blocks or rails, or provide the corner with a radius smaller than corner radius r_1 and r_2 specified in Table 6.

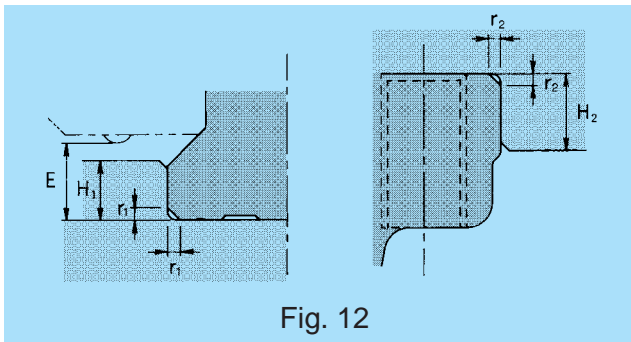
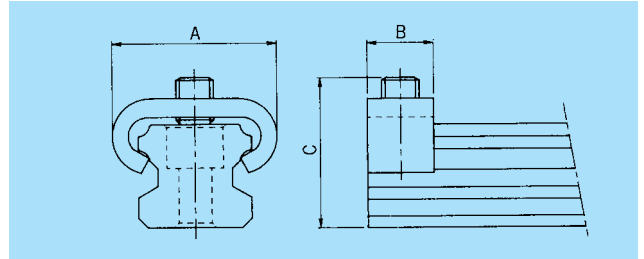

Fig. 12

Stopper

In miniature LM Guide HSR 8, 10, and 12, removal of the LM block from the rail may cause the balls to fall off. To prevent this, the LM block is delivered with stoppers installed. If the LM Guide is used without the stoppers, be careful not to allow the LM block to overrun.



Unit : mm

Model No.	A	B	C
HSR 8	12.5	6	10
HSR 10	15	6	11
HSR 12	18.5	7	16

Table 6 Mounting-Surface Shoulder Height and Corner Radius

Unit : mm

Model No.	LM-rail corner radius r_1 (Max.)	LM-block corner radius r_2 (Max.)	LM-rail shoulder height H_1	LM-block shoulder height H_2	E
HSR 8	0.3	0.5	1.6	6	2.1
HSR 10	0.3	0.5	1.7	5	2.2
HSR 12	0.8	0.5	2.6	4	3.1
HSR 15	0.5	0.5	3	4	3.5
HSR 20	0.5	0.5	3.5	5	4
HSR 25	1.0	1.0	5	5	5.5
HSR 30	1.0	1.0	5	5	7
HSR 35	1.0	1.0	6	6	7.5
HSR 45	1.0	1.0	8	8	10
HSR 55	1.5	1.5	10	10	13
HSR 65	1.5	1.5	10	10	14
HSR 85	1.5	1.5	12	14	16
HSR 100	2.0	2.0	16	16	20.5
HSR 120	2.5	2.5	17	18	20
HSR 150	2.5	2.5	20	20	22.5

LM-Rail Standard and Maximum Lengths

Table 7 presents the standard and maximum lengths of LM rails for type HSR. If your maximum length is not within the range of this table, we offer special LM rails intended for connected use.

For dimension G when a special length is specified, we recommend those listed in Table 7. A large dimension

G tends to reduce stability at the rail ends, which may degrade accuracy.

For connected use, we offer LM rails that ensure the elimination of level differences at joints. Therefore, when placing an order, please specify the overall length of the LM rails you require.

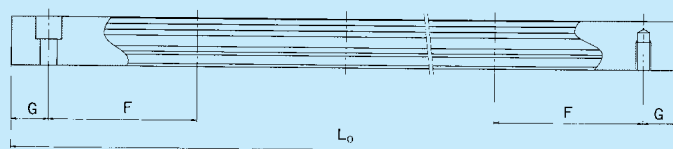

Table 7 Type-HSR LM-Rail Standard and Maximum Lengths

Unit : mm

Model No.	HSR8	HSR10	HSR12	HSR15	HSR20	HSR25	HSR30	HSR35	HSR45	HSR55	HSR65	HSR85	HSR100	HSR120	HSR150
	35	45	70	160	220	220	280	280	570	780	1270	1530	1340	1470	1600
	55	70	110	220	280	280	360	360	675	900	1570	1890	1760	1930	2100
	75	95	150	280	340	340	440	440	780	1020	2020	2250	2180	2390	2350
	95	120	190	340	400	400	520	520	885	1140	2620	2610	2600		
	115	145	230	400	460	460	600	600	990	1260					
	135	170	270	460	520	520	680	680	1095	1380					
	155	195	310	520	580	580	760	760	1200	1500					
	175	220	350	580	640	640	840	840	1305	1620					
	195	245	390	640	700	700	920	920	1410	1740					
	215	270	430	700	760	760	1000	1000	1515	1860					
	235	295	470	760	820	820	1080	1080	1620	1980					
	255	320	510	820	940	940	1160	1160	1725	2100					
	275	345	550	940	1000	1000	1240	1240	1830	2220					
		370	590	1000	1060	1060	1320	1320	1935	2340					
		395	630	1060	1120	1120	1400	1400	2040	2460					
		420	670	1120	1180	1180	1480	1480	2145	2580					
		445		1180	1240	1240	1560	1560	2250	2700					
		470		1240	1360	1300	1640	1640	2355	2820					
				1360	1480	1360	1720	1720	2460	2940					
				1480	1600	1420	1800	1800	2565	3060					
				1600	1720	1480	1880	1880	2670						
					1840	1540	1960	1960	2775						
					1960	1600	2040	2040	2880						
					2080	1720	2200	2200	2985						
					2200	1840	2360	2360	3090						
						1960	2520	2520							
						2080	2680	2680							
						2200	2840	2840							
						2320	3000	3000							
						2440									
Standard pitch F	20	25	40	60	60	60	80	80	105	120	150	180	210	230	250
G	7.5	10	15	20	20	20	20	20	22.5	30	35	45	40	45	50
Max. length	(275)	(470)	(670)	2500 (1240)	3000 (1480)	3000 (2020)	3000 (2520)	3000 (2520)	3090	3060	3000	3000	3000	3000	3000

- Notes:
- The maximum length differs by accuracy grade. Contact us for details.
 - In special cases in which connected use is impossible but one of the maximum lengths specified here is required, contact us.
 - Numbers in parentheses indicate the maximum lengths of stainless steel types.

Tapped-Hole Rail Models of Type HSR

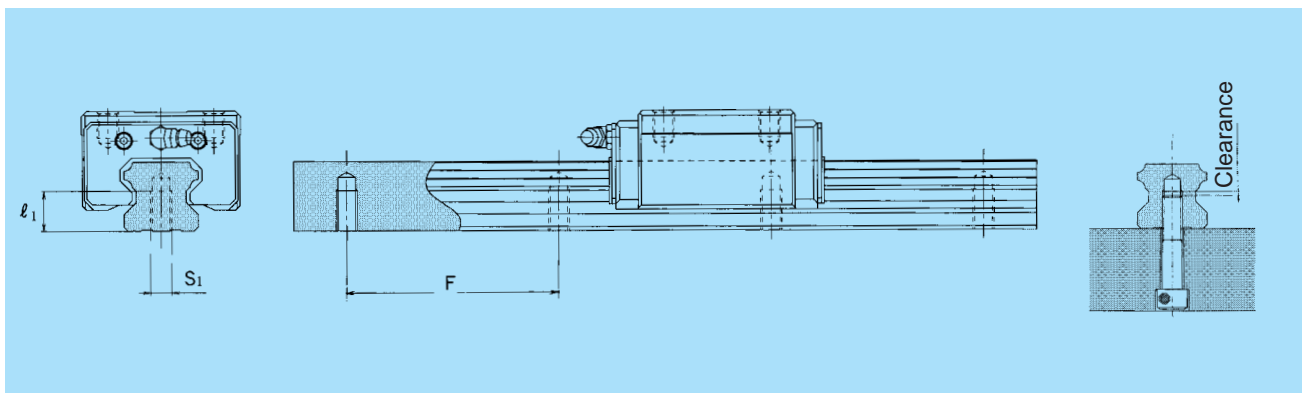
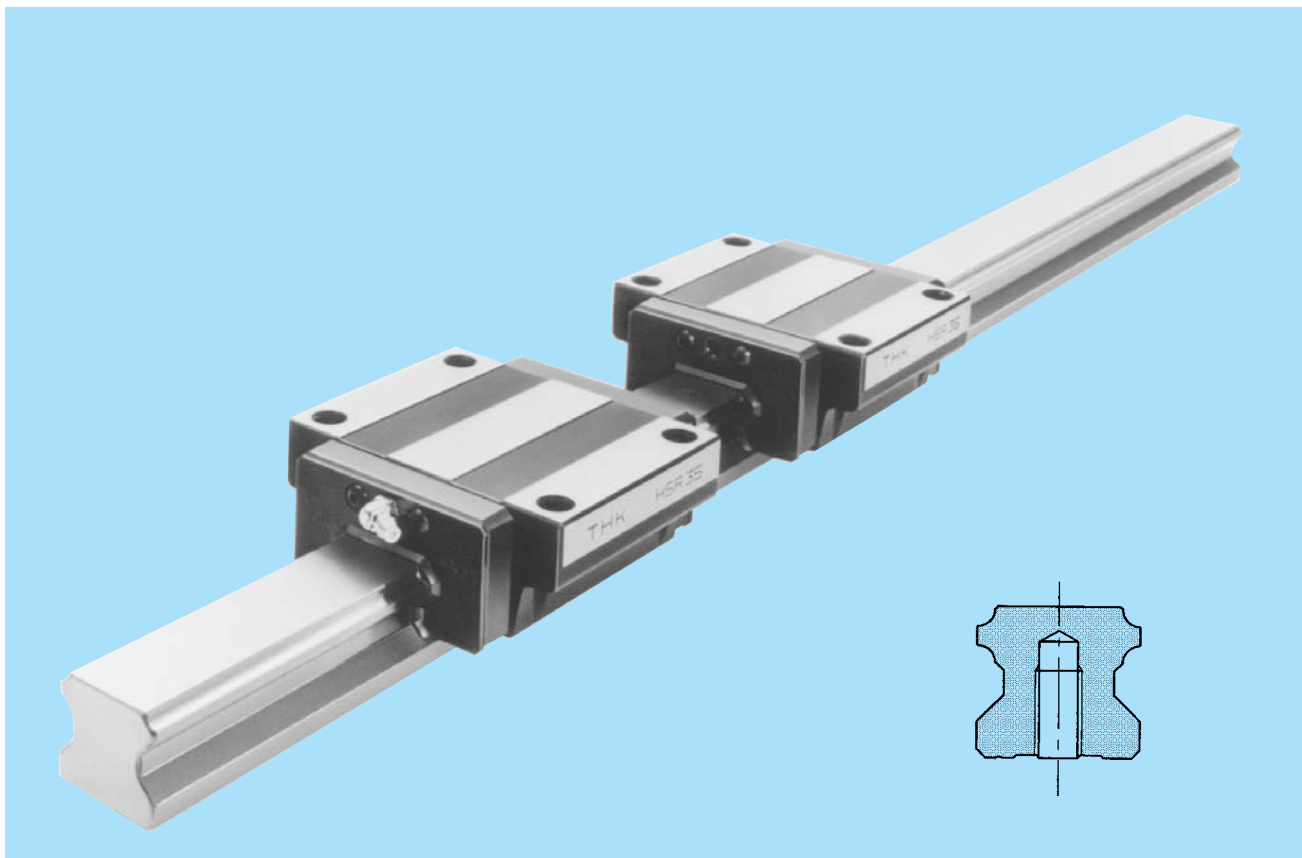

Table 8 Tapped-Hole Rail Dimensions

Unit : mm

Model No.	S ₁	Effective tapped thread length l_1
HSR 15	M5 × 0.8	8
HSR 20	M6	10
HSR 25	M6	12
HSR 30	M8	15
HSR 35	M8	17
HSR 45	M12	24
HSR 55	M14	24
HSR 65	M20	30

1. Set the bolt length such that a clearance of 2 to 5 mm is reserved at the tip of each bolt when the bolt is tightened over the full length of the effective tapped thread (diagram shown above).

2. Model-number coding

HSR30 A2UU + 1000LH K

Tap-type symbol

3. The rail tap types also apply to type HSR-YR.
4. For the standard tapping pitch (F), see page A-230.

HSR-A Type HSR-LA Type

Standard type

HSR-AM Type HSR-LAM Type

Stainless-steel type

Four-tapped-hole type

HSR-A Type
(Heavy-load type)

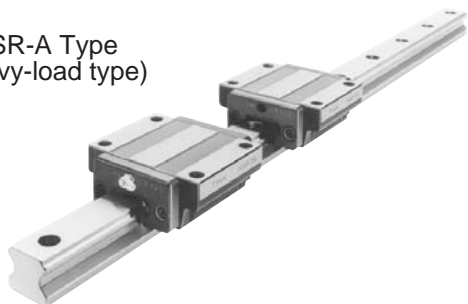

HSR-LA Type
(Ultra-heavy-load type)

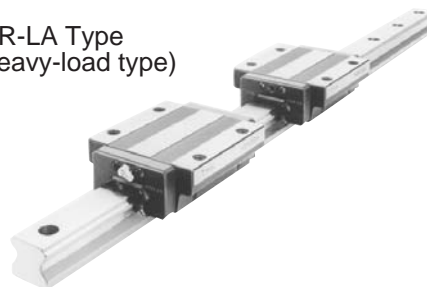

Model No.	External dimensions			LM-block dimensions								
	Height M	Width W	Length L	B	C	$S \times \ell$	L_1	T	T_1	K	N	E
HSR 15 A HSR 15 AM	24	47	56.6	38	30	M5 × 0.8 × 11	38.8	7	11	19.3	4.3	5.5
HSR 20 A HSR 20 AM	30	63	74	53	40	M6 × 10	50.8	10	10	26	5	12
HSR 20 LA HSR 20 LAM	30	63	90	53	40	M6 × 10	66.8	10	10	26	5	12
HSR 25 A HSR 25 AM	36	70	83.5	57	45	M8 × 16	59.5	10	16	30.5	6	12
HSR 25 LA HSR 25 LAM	36	70	102.5	57	45	M8 × 16	78.6	10	16	30.5	6	12
HSR 30 A HSR 30 AM	42	90	98	72	52	M10 × 18	70.4	10	18	35	7	12
HSR 30 LA HSR 30 LAM	42	90	121	72	52	M10 × 18	93	10	18	35	7	12
HSR 35 A HSR 35 AM	48	100	109.5	82	62	M10 × 21	80.4	13	21	40.5	8	12
HSR 35 LA HSR 35 LAM	48	100	135	82	62	M10 × 21	105.8	13	21	40.5	8	12
HSR 45 A HSR 45 LA	60	120	139 171	100	80	M12 × 15	98 129.8	14	25	50	10	16
HSR 55 A HSR 55 LA	70	140	163 201	116	95	M14 × 17	118 156.1	15	29	57	11	16
HSR 65 A HSR 65 LA	90	170	186 246	142	110	M16 × 23	147 206.5	23	37	76	19	16
HSR 85 A HSR 85 LA	110	215	247 303	185	140	M20 × 30	178.6 236	30	55	94	23	16

Notes:

- An “M” in a model number indicates that the corresponding LM blocks, rails, and balls are made of stainless steel and are therefore corrosion- and environment-resistant.
- For products marked with a “*”, stainless-steel end plates are available in cases in which they are to be used at 80°C or higher.

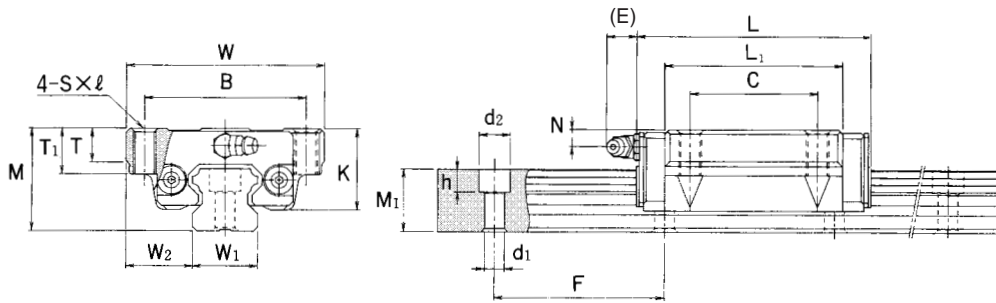

Unit : mm

Grease nipple	LM-rail dimensions					Basic load rating		Mass	
	Width W_1 ± 0.05	W_2	Height M_1	Pitch F	$d_1 \times d_2 \times h$	C kN	C_0 kN	LM block kg	LM rail kg/m
PB1021B	15	16	15	60	4.5×7.5×5.3	8.33	13.5	0.2	1.5
B-M6F	20	21.5	18	60	6×9.5×8.5	13.8	23.8	0.35	2.3
B-M6F	20	21.5	18	60	6×9.5×8.5	21.3	31.8	0.47	2.3
B-M6F	23	23.5	22	60	7×11×9	19.9	34.4	0.59	3.3
B-M6F	23	23.5	22	60	7×11×9	27.2	45.9	0.75	3.3
B-M6F	28	31	26	80	9×14×12	28	46.8	1.1	4.8
B-M6F	28	31	26	80	9×14×12	37.3	62.5	1.3	4.8
B-M6F	34	33	29	80	9×14×12	37.3	61.1	1.6	6.6
B-M6F	34	33	29	80	9×14×12	50.2	81.5	2.0	6.6
B-PT1/8	45	37.5	38	105	14×20×17	60 80.4	95.6 127	2.8 3.3	11.0
B-PT1/8	53	43.5	44	120	16×23×20	88.5 119	137 183	4.5 5.7	15.1
B-PT1/8	63	53.5	53	150	18×26×22	141 192	215 286	8.5 10.7	22.5
B-PT1/8	85	65	65	180	24×35×28	210 282	310 412	17.0 23.0	35.2

- For permissible static moments M_A , M_B , and M_C , see page A-219.
- For standard LM-rail lengths, see page A-230.
- For model-number coding, see page A-222.

HSR-B Type HSR-LB Type

Standard type

HSR-BM Type HSR-LBM Type

Stainless-steel type

Four-through-hole type

HSR-B Type
(Heavy-load type)

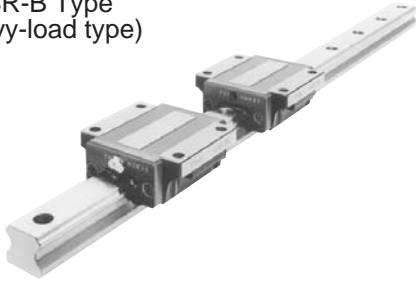

HSR-LB Type
(Ultra-heavy-load type)

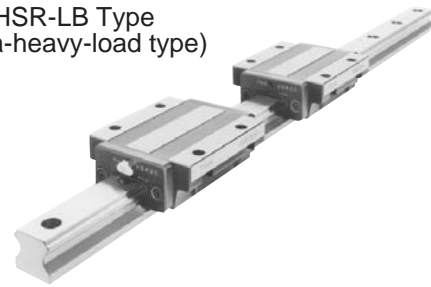

Model No.	External dimensions			LM-block dimensions								
	Height M	Width W	Length L	B	C	H	L ₁	T	T ₁	K	N	E
HSR 15 B HSR 15 BM	24	47	56.6	38	30	4.5	38.8	7	11	19.3	4.3	5.5
HSR 20 B HSR 20 BM	30	63	74	53	40	6	50.8	10	10	26	5	12
HSR 20 LB HSR 20 LBM	30	63	90	53	40	6	66.8	10	10	26	5	12
HSR 25 B HSR 25 BM	36	70	83.5	57	45	7	59.5	10	16	30.5	6	12
HSR 25 LB HSR 25 LBM	36	70	102.5	57	45	7	78.6	10	16	30.5	6	12
HSR 30 B HSR 30 BM	42	90	98	72	52	9	70.4	10	18	35	7	12
HSR 30 LB HSR 30 LBM	42	90	121	72	52	9	93	10	18	35	7	12
HSR 35 B HSR 35 BM	48	100	109.5	82	62	9	80.4	13	21	40.5	8	12
HSR 35 LB HSR 35 LBM	48	100	135	82	62	9	105.8	13	21	40.5	8	12
HSR 45 B HSR 45 LB	60	120	139 171	100	80	11	98 129.8	15	25	50	10	16
HSR 55 B HSR 55 LB	70	140	163 201	116	95	14	118 156.1	17	29	57	11	16
HSR 65 B HSR 65 LB	90	170	186 246	142	110	16	147 206.5	23	37	76	19	16
HSR 85 B HSR 85 LB	110	215	247 303	185	140	18	178.6 236	30	55	94	23	16

Notes:

- An “M” in a model number indicates that the corresponding LM blocks, rails, and balls are made of stainless steel and are therefore corrosion- and environment-resistant.
- For products marked with a “*”, stainless-steel end plates are available in cases in which they are to be used at 80°C or higher.

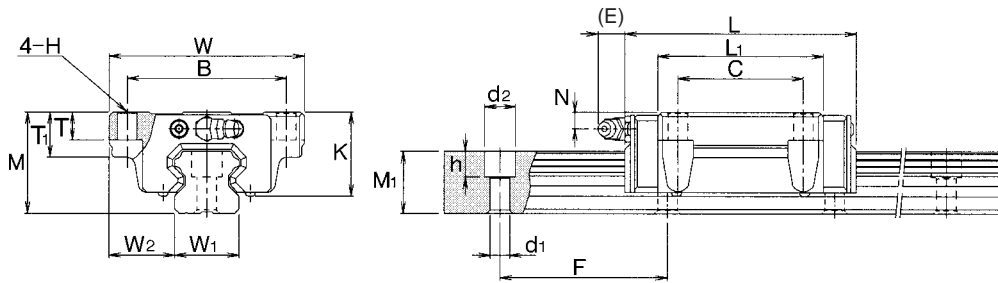

Unit : mm

Grease nipple	LM-rail dimensions					Basic load rating		Mass	
	Width W_1 ± 0.05	W_2	Height M_1	Pitch F	$d_1 \times d_2 \times h$	C kN	C_0 kN	LM block kg	LM rail kg/m
PB1021B	15	16	15	60	4.5×7.5×5.3	8.33	13.5	0.2	1.5
B-M6F	20	21.5	18	60	6×9.5×8.5	13.8	23.8	0.35	2.3
B-M6F	20	21.5	18	60	6×9.5×8.5	21.3	31.8	0.47	2.3
B-M6F	23	23.5	22	60	7×11×9	19.9	34.4	0.59	3.3
B-M6F	23	23.5	22	60	7×11×9	27.2	45.9	0.75	3.3
B-M6F	28	31	26	80	9×14×12	28	46.8	1.1	4.8
B-M6F	28	31	26	80	9×14×12	37.3	62.5	1.3	4.8
B-M6F	34	33	29	80	9×14×12	37.3	61.1	1.6	6.6
B-M6F	34	33	29	80	9×14×12	50.2	81.5	2.0	6.6
B-PT1/8	45	37.5	38	105	14×20×17	60 80.4	95.6 127	2.8 3.3	11.0
B-PT1/8	53	43.5	44	120	16×23×20	88.5 119	137 183	4.5 5.7	15.1
B-PT1/8	63	53.5	53	150	18×26×22	141 192	215 286	8.5 10.7	22.5
B-PT1/8	85	65	65	180	24×35×28	210 282	310 412	17.0 23.0	35.2

- For permissible static moments M_A , M_B , and M_C , see page A-219.
- For standard LM-rail lengths, see page A-230.
- For model-number coding, see page A-222.

HSR-R Type HSR-LR Type

Standard type

HSR-RM Type HSR-LRM Type

Stainless-steel type

Four-tapped-hole type

HSR-R Type
(Heavy-load type)

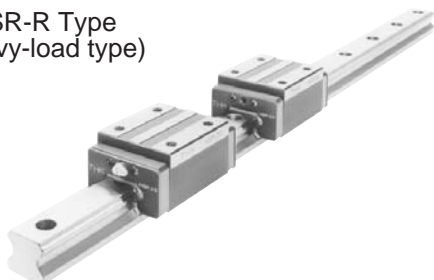

HSR-LR Type
(Ultra-heavy-load type)

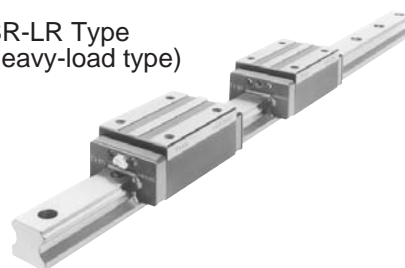

Model No.	External dimensions			LM-block dimensions							
	Height M	Width W	Length L	B	C	S × ℓ	L ₁	T	K	N	E
HSR 15 R HSR 15 RM	28	34	56.6	26	26	M4 × 0.7 × 5	38.8	6	23.3	8.3	5.5
HSR 20 R HSR 20 RM	30	44	74	32	36	M5 × 0.8 × 6	50.8	8	26	5	12
HSR 20 LR HSR 20 LRM	30	44	90	32	50	M5 × 0.8 × 6	66.8	8	26	5	12
HSR 25 R HSR 25 RM	40	48	83.5	35	35	M6 × 8	59.5	8	34.5	10	12
HSR 25 LR HSR 25 LRM	40	48	102.5	35	50	M6 × 8	78.6	8	34.5	10	12
HSR 30 R HSR 30 RM	45	60	98	40	40	M8 × 10	70.4	8	38	10	12
HSR 30 LR HSR 30 LRM	45	60	121	40	60	M8 × 10	93	8	38	10	12
HSR 35 R HSR 35 RM	55	70	109.5	50	50	M8 × 12	80.4	10	47.5	15	12
HSR 35 LR HSR 35 LRM	55	70	135	50	72	M8 × 12	105.8	10	47.5	15	12
HSR 45 R HSR 45 LR	70	86	139 171	60	60 80	M10 × 17	98 129.8	15	60	20	16
HSR 55 R HSR 55 LR	80	100	163 201	75	75 95	M12 × 18	118 156.1	18	67	21	16
HSR 65 R HSR 65 LR	90	126	186 246	76	70 120	M16 × 20	147 206.5	23	76	19	16
HSR 85 R HSR 85 LR	110	156	247 303	100	80 140	M18 × 25	178.6 236	30	94	23	16

Notes:

- An “M” in a model number indicates that the corresponding LM blocks, rails, and balls are made of stainless steel and are therefore corrosion- and environment-resistant.
- For products marked with a “*”, stainless-steel end plates are available in cases in which they are to be used at 80°C or higher.

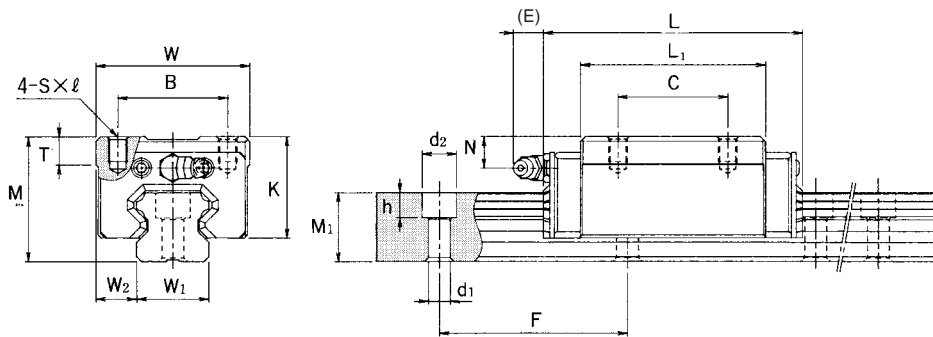

Unit : mm

Grease nipple	LM-rail dimensions					Basic load rating		Mass	
	Width W_1 ± 0.05	W_2	Height M_1	Pitch F	$d_1 \times d_2 \times h$	C kN	C_0 kN	LM block kg	LM rail kg/m
PB1021B	15	9.5	15	60	4.5×7.5×5.3	8.33	13.5	0.18	1.5
B-M6F	20	12	18	60	6×9.5×8.5	13.8	23.8	0.25	2.3
B-M6F	20	12	18	60	6×9.5×8.5	21.3	31.8	0.35	2.3
B-M6F	23	12.5	22	60	7×11×9	19.9	34.4	0.54	3.3
B-M6F	23	12.5	22	60	7×11×9	27.2	45.9	0.67	3.3
B-M6F	28	16	26	80	9×14×12	28	46.8	0.9	4.8
B-M6F	28	16	26	80	9×14×12	37.3	62.5	1.1	4.8
B-M6F	34	18	29	80	9×14×12	37.3	61.1	1.5	6.6
B-M6F	34	18	29	80	9×14×12	50.2	81.5	2.0	6.6
B-PT1/8	45	20.5	38	105	14×20×17	60 80.4	95.6 127	2.6 3.1	11.0
B-PT1/8	53	23.5	44	120	16×23×20	88.5 119	137 183	4.3 5.4	15.1
B-PT1/8	63	31.5	53	150	18×26×22	141 192	215 286	7.3 9.3	22.5
B-PT1/8	85	35.5	65	180	24×35×28	210 282	310 412	13.0 16.0	35.2

- For permissible static moments M_A , M_B , and M_C , see page A-219.
- For standard LM-rail lengths, see page A-230.
- For model-number coding, see page A-222.

Miniature LM Guide Type HSR-R M

Stainless type



Model No.	External dimensions			LM-block dimensions							
	Height M	Width W	Length L	B	C	$S \times \ell$	L_1	T	K	N	E
HSR 8R M	11	16	24	10	10	M2 × 0.4 × 2.5	15	-	8.9	2.6	-
HSR 10R M	13	20	31	13	12	M2.6 × 0.45 × 2.5	20.1	-	10.8	3.5	-
HSR 12R M	20	27	45	15	15	M4 × 0.7 × 4.5	30.5	6	16.9	5.2	4.0

Notes:

- An “M” in a model number indicates that the corresponding LM blocks, rails, and balls are made of stainless steel and are therefore corrosion- and environment-resistant.
- For permissible static moments M_A , M_B , and M_C , see page A-219.

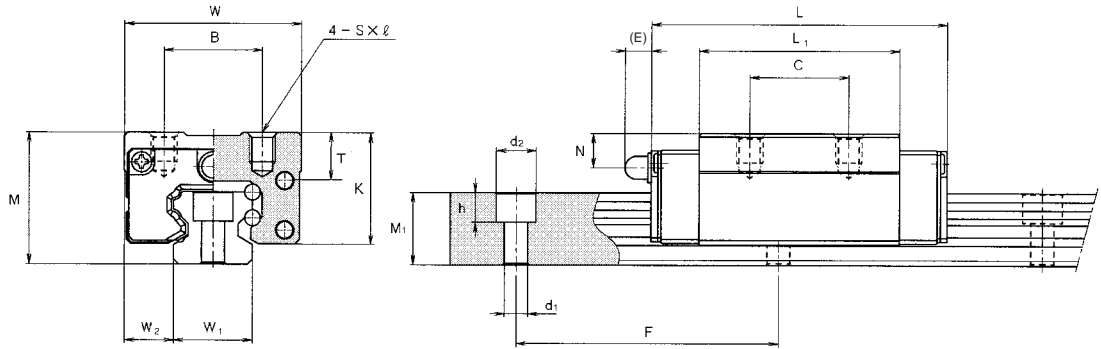

Unit : mm

Grease nipple	LM-rail dimensions					Basic load rating		Mass	
	Width W_1 ± 0.05	W_2	Height M_1	Pitch F	$d_1 \times d_2 \times h$	C N	C_0 N	LM block kg	LM rail kg/m
2.2 Oil hole	8	4	6	20	$2.4 \times 4.2 \times 2.3$	1080	2160	0.012	0.30
2.5 Oil hole	10	5	7	25	$3.5 \times 6 \times 3.3$	1960	3820	0.025	0.45
PB-107	12	7.5	11	40	$3.5 \times 6 \times 4.5$	4700	8530	0.080	0.83

- For standard LM-rail lengths, see page A-230.
- For model-number coding, see page A-222.

Types HSR-HA, HSR-HB, and HSR-HR

Heavy-duty nine- and six-bolt type

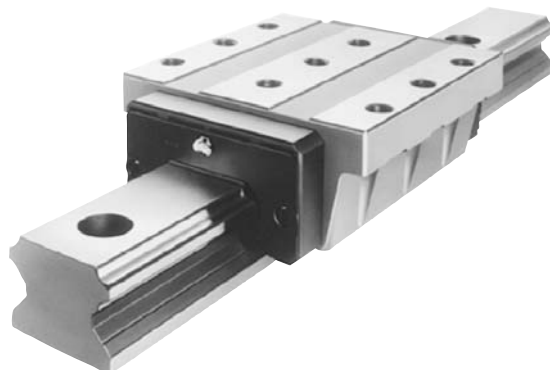

Model No.	External dimensions			LM-block dimensions									
	Height M	Width W	Length L	B	C	S×ℓ	H	h ₁	L ₁	T	K	N	E
HSR 100 HA	120	250	334	110	100	M18 × 35	-	-	261	35	100	23	16
HSR 100 HB		250		-		20	23						
HSR 100 HR		200		M18 × 27		-	-						
HSR 120 HA	130	290	365	125	105	M20 × 38	-	-	287	38	110	26.5	16
HSR 120 HB		290		-		22	23						
HSR 120 HR		220		M20 × 30		-	-						
HSR 150 HA	145	350	396	150	115	M24 × 40	-	-	314	40	123	29	16
HSR 150 HB		350		-		26	23.5						
HSR 150 HR		266		M24 × 35		-	-						

Notes:

- For permissible static moments M_A , M_B , and M_C , see page A-219.
- For model-number coding, see page A-222.

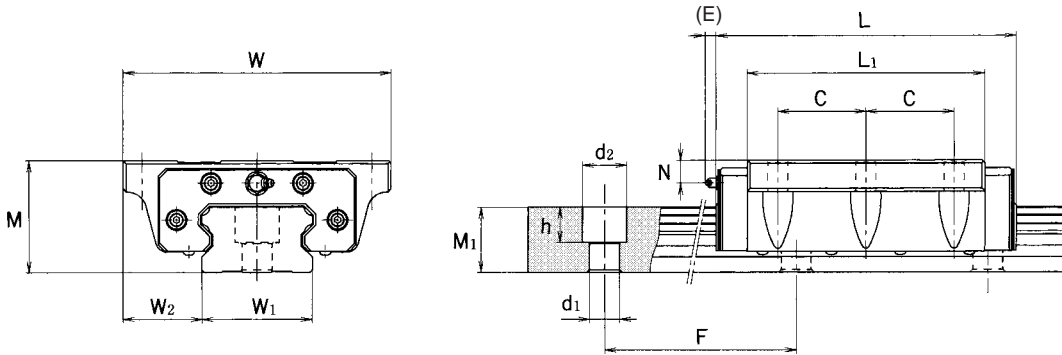

Unit : mm

Grease nipple	LM-rail dimensions					Basic load rating		Mass	
	Width W_1 ± 0.05	W_2	Height M_1	Pitch F	$d_1 \times d_2 \times h$	C kN	C_0 kN	LM block kg	LM rail kg/m
B-PT1/4	100	75 75 50	70	210	26×39×32	351	506	32	49
B-PT1/4	114	88 88 53	75	230	33×48×43	429	612	43	61
B-PT1/4	144	103 103 61	85	250	39×58×46	518	728	62	87

- For standard LM-rail lengths, see page A-230.

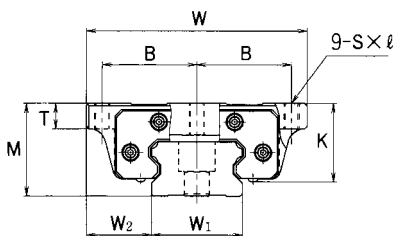

HSR-HA Type

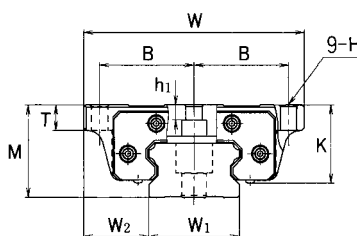

HSR-HB Type

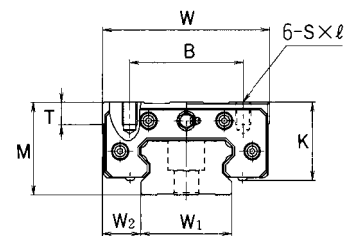

HSR-HR Type