

Roller Rail Systems

The Drive & Control Company

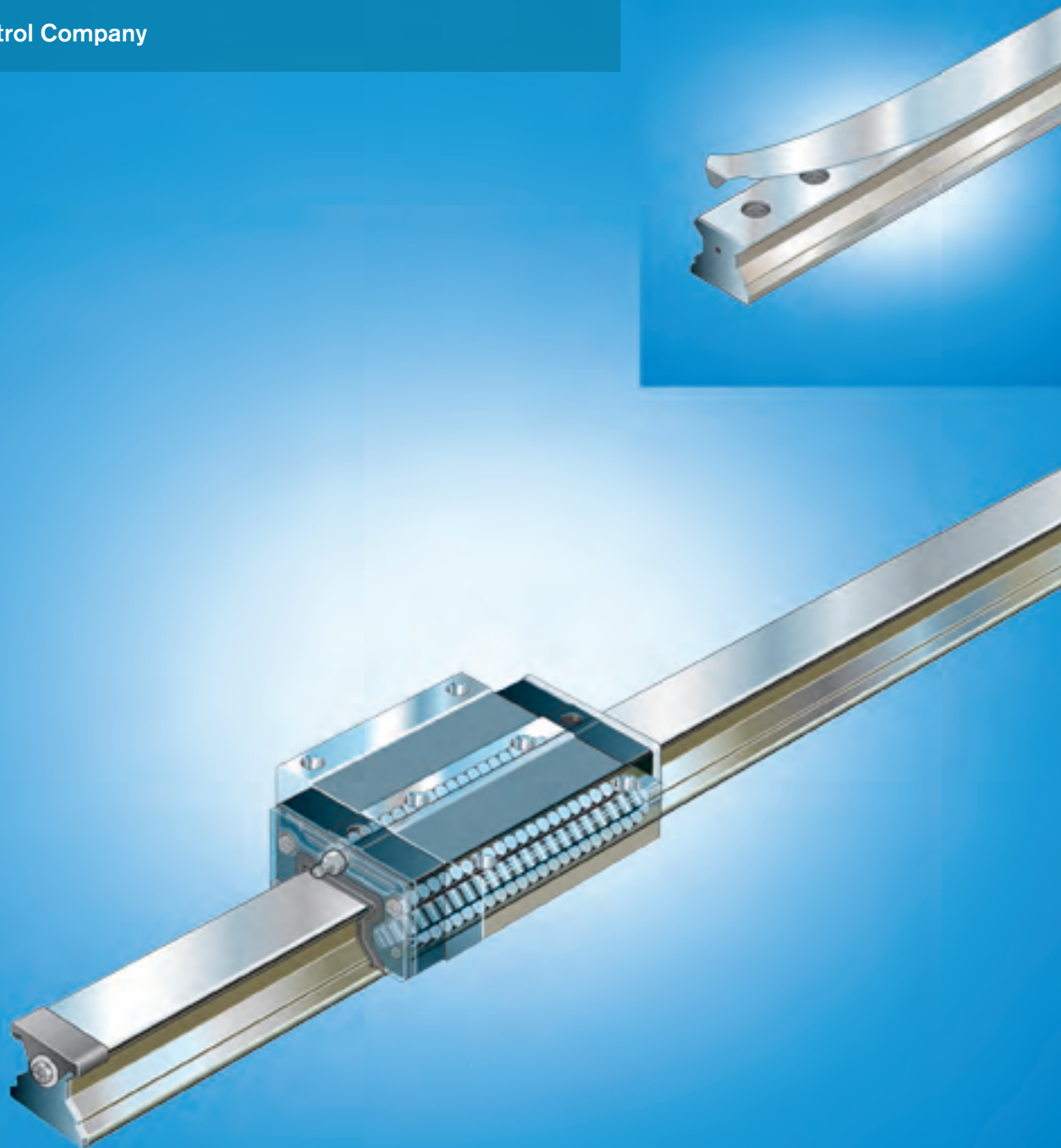

Linear Motion and Assembly Technologies

Ball Rail Systems

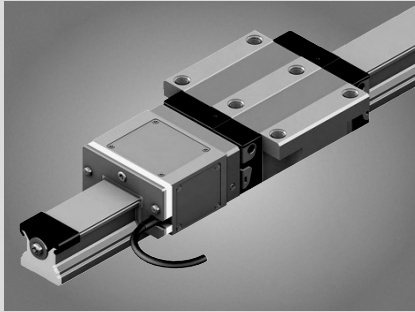

Roller Rail Systems

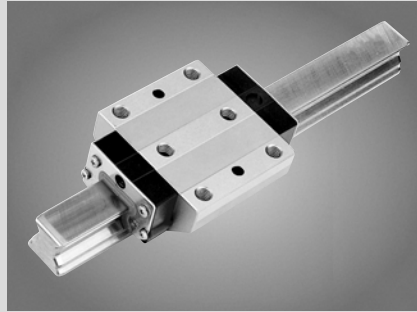

Linear Bushings and Shafts



Ball Screw Drives



Linear Motion Systems

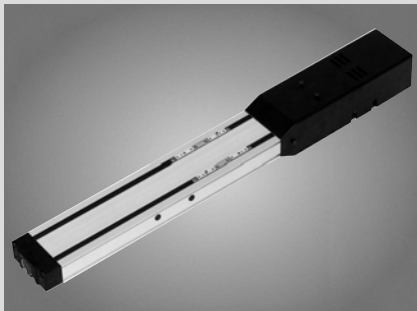

Basic Mechanical Elements

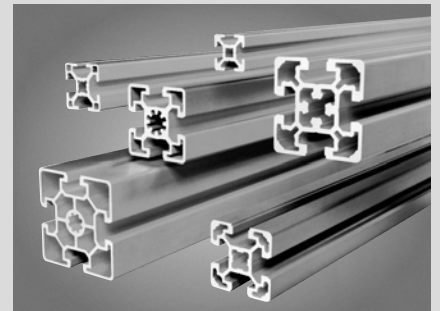

Manual Production Systems



Assembly Conveyors



VarioFlow Conveyors

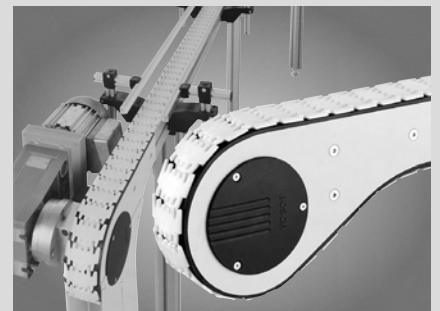

Roller Rail Systems

General Product Description	4	Accessories and Spare Parts	106
New Features at a Glance	4	Accessories for Standard Runner Blocks	106
Product Description	6	Metal scraper	107
Product Overview with Load Capacities and Rail Lengths	8	Viton or NBR wiper seal, two-piece	108
Combination Options	14	Set of Viton seals with metal scraper	109
General Technical Data and Calculations	16	Standard lube plate	110
Selection of Accuracy Classes	22	Front lube units	111
Selection of System Preload	25	Protective bellows	116
Standard Runner Blocks, Steel version	26	Accessories for Guide Rails	120
Product Description	26	Notes on cover strip	121
Rigidity	30	Cover strip, separate	122
Runner Blocks	38	Expanding tool	123
FNS – Flanged, normal, standard height	38	Cover strip mounting kit	123
FLS – Flanged, long, standard height	40	Parts for securing the cover strip	124
SNH – Slimline, normal, high	42	Plastic mounting hole plugs	125
SLH – Slimline, long, high	44	Steel mounting hole plugs	125
Runner Blocks with Aluminum End Caps	46	Mounting tool for steel mounting hole plugs	125
Runner Blocks for Oil and Grease Lubrication From Above	48	General Accessories – Runner Blocks	126
Runner Blocks for Central Oil Lubrication Systems	50	Lube nipples	127
Runner Blocks for Wall Mounting	52	Lube fittings	127
Standard Runner Blocks, Resist CR version	56	O-rings	129
Standard Guide Rails, Steel version	62	Combination options for lube fittings	130
Product Description	62	Mounting aid for heavy duty runner blocks	132
Ordering Examples	63	General Accessories – Guide Rails	133
Guide rails	64	Adjusting shafts	134
With Cover Strip and Protective End Caps	64	Wedge profile	135
With Cover Strip and Strip Clamps	66	Mounting runner block	136
For Cover Strip	68	Spare Parts	138
With Plastic Mounting Hole Plugs	70	End seal	139
For Steel Mounting Hole Plugs	72	Set of end cap with end seal	140
For Mounting From Below	74	Transport and mounting arbor for runner blocks	141
Standard Guide Rails, Resist CR version	76	Mounting Instructions	142
V-Guide Rails	82	General Mounting Instructions	142
Product Description	82	Mounting	147
V-Guide Rails without Mounting Holes	84	Load on the screw connections	147
Pressure Pieces for V-Guide Rails	85	Standard Roller Rail Systems	148
Wide Roller Rail Systems	86	Wide Roller Rail Systems	150
Product Description	86	Heavy Duty Roller Rail Systems	151
Rigidity	88	Lubrication and Maintenance	152
Wide Runner Blocks, Steel and Resist CR versions	92	Lubrication	152
Wide Guide Rails, Steel and Resist CR versions	94	Grease lubrication	152
Heavy Duty Roller Rail Systems	96	Liquid grease lubrication	155
Product Description	96	Oil lubrication	159
Rigidity	98	Design calculation example	163
Heavy Duty Runner Blocks, Steel and Resist CR versions	100	Lubrication from above	165
Heavy Duty Guide Rails, Steel and Resist CR versions	104	Maintenance	166

General Product Description

New Features at a Glance

New Runner Blocks for oil and grease lubrication from above

The dimensions, load capacities, rigidity and moment loads correspond to those of standard runner blocks R18.. ... 10.

Special feature:

Runner blocks R18.. ... 16 have been prepared for oil and grease lubrication from above. In the high runner blocks S.H, the vertical clearance between the end caps and an attachment mounting surface with integrated lube adapters has been designed for ease of maintenance.

How to recognize them:

The top lube holes at both ends have already been opened, but they are closed with screws for shipment (O-rings for sealing the lube fittings are provided with the runner blocks).

FNS R1851 ... 16

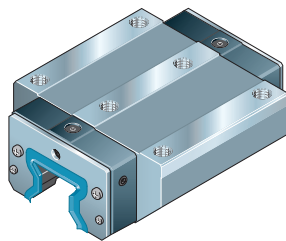

SNH R1821 ... 16

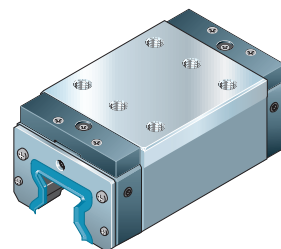

FLS R1853 ... 16

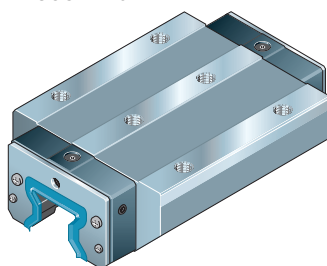

SLH R1824 ... 16

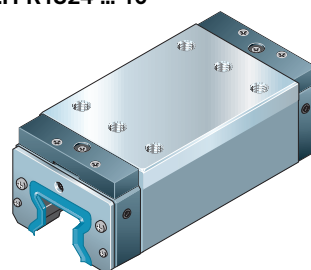
**New Runner Blocks (exclusively) for central oil lubrication via dosing valves**

The dimensions, load capacities, rigidity and moment loads correspond to those of standard runner blocks R18.. ... 10.

Special feature:

Runner blocks R18.. ... 17 have smaller lube ducts. They need only small quantities of lube oil even when wall-mounted and are therefore suitable for all mounting orientations.

How to recognize them:

The end caps are gray. In the high runner blocks S.H, the vertical clearance between the end caps and an attachment mounting surface with integrated lube adapters has been designed for ease of maintenance. The top lube holes have already been opened, but they are closed with screws for shipment (O-rings for sealing the lube fittings are provided with the runner blocks).

FNS R1851 ... 17

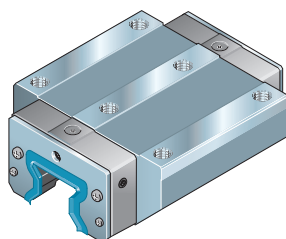

SNH R1821 ... 17

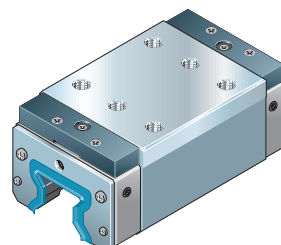

FLS R1853 ... 17

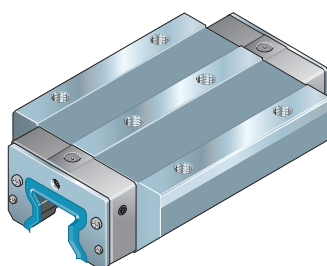

SLH R1824 ... 17

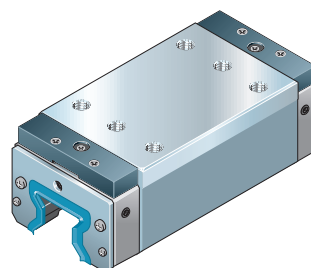
**Runner block short names**

FNS = Flanged, normal, standard height

FLS = Flanged, long, standard height

SNH = Slimline, normal, high

SLH = Slimline, long, high

Heavy Duty Runner Blocks now also in size 100

Heavy duty steel runner blocks now also available in size 100.

Options

Corrosion-resistant runner blocks, Resist CR, matte silver hard chrome plated.

Part numbers: FNS R1861 2.. 60 or FLS R1863 2.. 60

FNS R1861 2.. 10

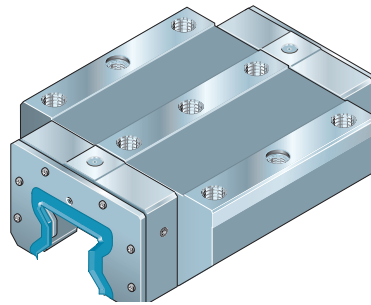

(Illustrations not to scale)

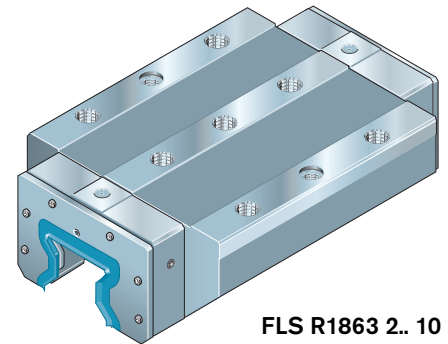

FLS R1863 2.. 10

New V-Guide Rails without mounting holes

Special feature:

The V-guide rails R1808 .1. 3. have no mounting holes. Instead, pressure pieces are used to push them up against an inclined reference edge, align them and fix them in place.

Advantages:

- Optimally smooth runner block travel, since there are no mounting holes in the guide rail
- Improved straightness through uninterrupted guide rail profile
- Smooth rail surface for optimal sealing action
- Cost-saving – only one row of holes necessary for mounting and alignment
- Number of pressure pieces can be varied to match loads
- Mounting base can be machined using standard profile milling tools

V-Guide Rail R1808 .1. 3.

Without mounting holes
Mounting with pressure pieces

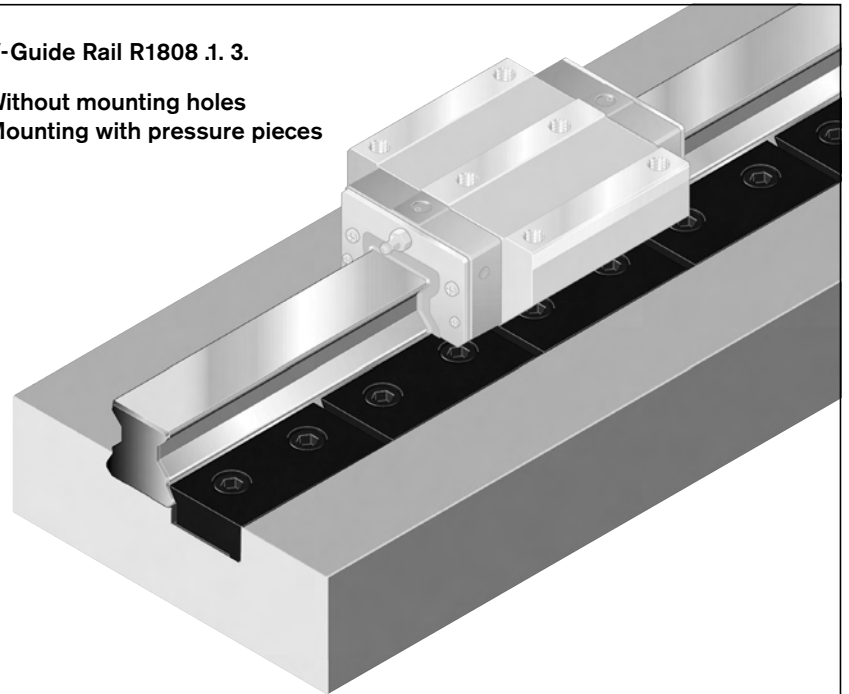

New Resist CR coating: matte silver hard chrome plated

Corrosion-resistant runner blocks and guide rails in Resist CR, matte silver hard chrome plated, replace the runner blocks and guide rails with zinc-iron coating.

Resist CR runner blocks and guide rails come in accuracy class H; accuracy classes P and SP on request.

One-piece Resist CR guide rails are available in two versions:

- End faces **uncoated**, on request in some cases
- End faces, chamfers and end-face threads coated

In composite Resist CR guide rails the joint faces are coated as well as the end faces.

New codes for Roller Runner Block preload classes

Preload classes

- C1 = preload 3% C, manufactured on special request
- C2 = preload 8% C
- C3 = preload 13% C

Wide and heavy duty runner blocks are not available in preload class C1. Please refer also to "Selection of System Preload".

General Product Description

Product Description

Outstanding features

Rexroth Roller Rail Systems were specially developed for use in machine tools, industrial robots and general machine construction applications calling for compact, rolling-element linear motion guideways. They are available in various accuracy classes, each with extremely high load capacity and high rigidity. Standard Roller Rail Systems are suitable for all typical applications. These space-saving assemblies in many common sizes afford the same high load capacities in all four major planes of load application. Standard runner blocks can also be supplied for special conditions of installation and use and for special working environments. Wide Roller Rail Systems were developed to cater for high moment loads and highest rigidity requirements. For heavy duty applications there is a choice of Heavy Duty Roller Rail Systems.

Make up your own compact linear motion guideways from interchangeable standard stock elements...

Rexroth fabricates its guide rails and runner blocks with such high precision that each individual component element can be replaced by another at any time. This makes infinite combinations possible. Each element can be individually ordered and separately stocked. Both sides of the guide rail can be used as reference edges.

Accessories can be simply attached to the ends of the runner block.

Further highlights

- Uniform guide rail profile with or without cover strip allows unrestricted interchangeability of components across all runner block variants.
- Lube ports on all sides for maximum ease of maintenance
- Novel lube duct design minimizes lubricant consumption.
- Smooth running thanks to optimized roller recirculation and guidance
- Mounting of attachments to runner block from above or below
- Maximum rigidity under load from all directions through two additional mounting screw holes at the center of the runner block
- High torque capacity
- Optimized entry-section geometry and high number of rollers per track minimizes variation in elastic deflection.
- The runner block simply slides off its arbor and onto the rail.
- Integrated all-round sealing as standard

Options

- Corrosion-resistant runner blocks and guide rails in Resist CR, matte silver hard chrome plated, come in accuracy class H; accuracy classes P and SP on request

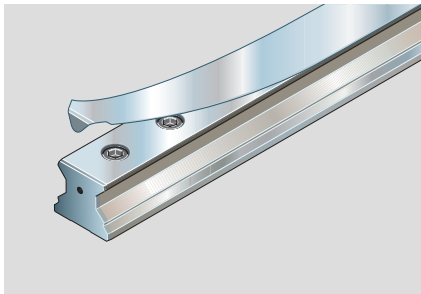

Proven cover strip for guide rail mounting holes

- A **single** cover for all holes – saves time and money
- Stainless spring steel to EN 10088
- Easy to fit – simply clip on and secure

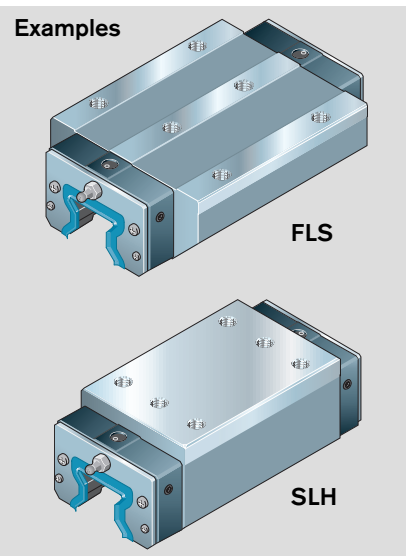

Runner block short names

- FNS = Flanged, normal, standard height
- FLS = Flanged, long, standard height
- BLS = Wide, long, standard height
- SNH = Slimline, normal, high
- SLH = Slimline, long, high

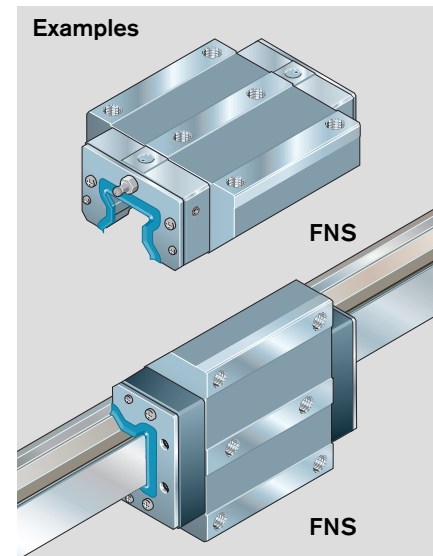

Runner blocks for special installation conditions and working environments

- with aluminum end caps
- for lubrication from above
- for wall mounting

**Standard Roller Rail System
(Example)**

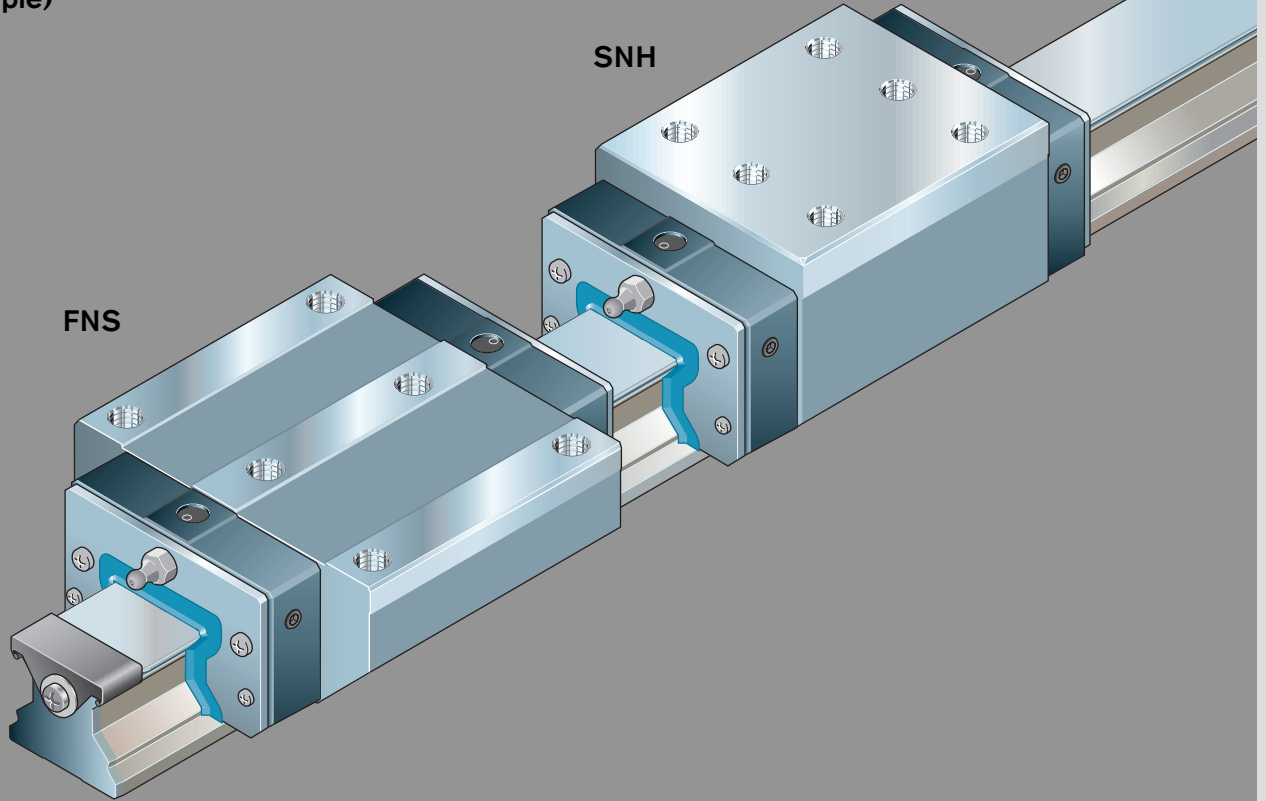

Wide Roller Rail System

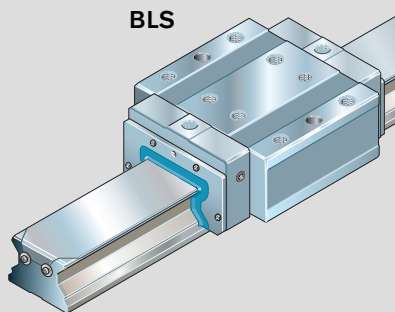

(Illustration not to scale)

Wide Roller Rail Systems for high moment loads, highest rigidity and travel accuracy

**Heavy Duty Roller Rail System
(Example)**

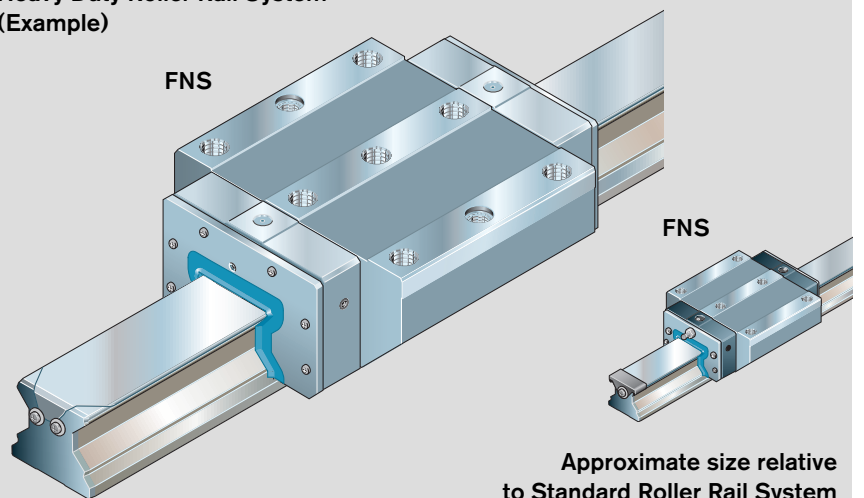

Approximate size relative to Standard Roller Rail System













Heavy Duty Roller Rail Systems for heavy duty applications

Approximate size comparison: Heavy Duty vs. Standard (example):

- Heavy duty runner block FNS R1861 on guide rail R1835 (size 125)
- Standard runner block FNS R1851 on guide rail R1805 (size 45)

General Product Description

Product Overview with Load Capacities











Standard Steel Runner Blocks			Page	Size	25	35	45	55	65
					Load capacities ¹⁾ (N)				
									
Steel runner blocks		Flanged, normal, standard height FNS R1851 ... 10	38	C C ₀	26 900 53 200	56 300 113 500	92 300 184 800	128 900 248 600	207 000 382 000
		Flanged, long, standard height FLS R1853 ... 10	40	C C ₀	33 300 70 000	69 700 149 300	119 200 256 600	165 000 345 300	265 500 525 600
		Slimline, normal, high SNH R1821 ... 10	42	C C ₀	26 900 53 200	56 300 113 500	92 300 184 800	128 900 248 600	– –
		Slimline, long, high SLH (SLS) ³⁾ R1824 ... 10	44	C C ₀	33 300 70 000	69 700 149 300	119 200 256 600	165 000 345 300	265 500 525 600
Steel runner blocks with aluminum end caps		Flanged, normal, standard height FNS R1851 ... 13	46	C C ₀	– ²⁾ – ²⁾	56 300 113 500	92 300 184 800	128 900 248 600	207 000 382 000
		Flanged, long, standard height FLS R1853 ... 13	46	C C ₀	– ²⁾ – ²⁾	69 700 149 300	119 200 256 600	165 000 345 300	265 500 525 600
		Slimline, normal, high SNH R1821 ... 13	46	C C ₀	– ²⁾ – ²⁾	56 300 113 500	92 300 184 800	128 900 248 600	– –
		Slimline, long, high SLH (SLS) ³⁾ R1824 ... 13	46	C C ₀	– ²⁾ – ²⁾	69 700 149 300	119 200 256 600	165 000 345 300	265 500 525 600
Steel runner blocks for oil and grease lubrication from above		Flanged, normal, standard height FNS R1851 ... 16	48	C C ₀	26 900 53 200	56 300 113 500	92 300 184 800	128 900 248 600	207 000 382 000
		Flanged, long, standard height FLS R1853 ... 16	48	C C ₀	33 300 70 000	69 700 149 300	119 200 256 600	165 000 345 300	265 500 525 600
		Slimline, normal, high SNH R1821 ... 16	48	C C ₀	26 900 53 200	56 300 113 500	92 300 184 800	128 900 248 600	– –
		Slimline, long, high SLH R1824 ... 16	48	C C ₀	33 300 70 000	69 700 149 300	119 200 256 600	165 000 345 300	– –

1) Basis for load capacities: The dynamic load capacities C are based on 100,000 m travel.

However, a travel of just 50,000 m is often taken as a basis. If this is the case, for comparison purposes: Multiply values **C** from the table by 1.23.

2) Size 25 in preparation







3) Size 65: Slimline, long, standard height SLS

Standard Steel Runner Blocks			Page	Size	25	35	45	55	65
					Load capacities ¹⁾ (N)				
Steel runner blocks for central oil lubrication systems		Flanged, normal, standard height FNS R1851 ... 17	50	C C ₀	- -	56 300 113 500	92 300 184 800	128 900 248 600	- -
		Flanged, long, standard height FLS R1853 ... 17	50	C C ₀	- -	69 700 149 300	119 200 256 600	165 000 345 300	- -
		Slimline, normal, high SNH R1821 ... 17	50	C C ₀	- -	56 300 113 500	92 300 184 800	128 900 248 600	- -
		Slimline, long, high SLH R1824 ... 17	50	C C ₀	- -	69 700 149 300	119 200 256 600	165 000 345 300	- -
Steel runner blocks for wall mounting		Flanged, normal, standard height FNS R1851 ... 18	52	C C ₀	- -	56 300 113 500	92 300 184 800	128 900 248 600	- -
		Flanged, long, standard height FLS R1853 ... 18	52	C C ₀	- -	69 700 149 300	119 200 256 600	165 000 345 300	- -
		Flanged, long, standard height FLS R1859 620 31	53	C C ₀	- -	- -	- -	- -	265 500 525 600
		Slimline, normal, high SNH R1821 ... 18	54	C C ₀	- -	56 300 113 500	92 300 184 800	128 900 248 600	- -
		Slimline, long, high SLH R1824 ... 18	55	C C ₀	- -	69 700 149 300	119 200 256 600	165 000 345 300	- -

1) Basis for load capacities: The dynamic load capacities C are based on 100,000 m travel. However, a travel of just 50,000 m is often taken as a basis. If this is the case, for comparison purposes: Multiply values C from the table by 1.23.

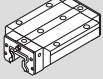
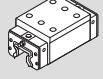
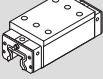
General Product Description

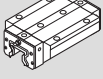
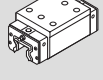
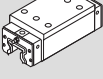
Product Overview with Load Capacities

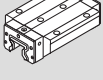
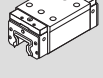
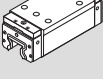
Standard Resist CR ¹⁾ Runner Blocks			Page	Size	25	35	45	55	65
					Load capacities ²⁾ (N)				
Resist CR ¹⁾ runner blocks		Flanged, normal, standard height FNS R1851 ... 60	57	C C ₀	26 900 53 200	56 300 113 500	92 300 184 800	128 900 248 600	207 000 382 000
		Flanged, long, standard height FLS R1853 ... 60	57	C C ₀	33 300 70 000	69 700 149 300	119 200 256 600	165 000 345 300	265 500 525 600
		Slimline, normal, high SNH R1821 ... 60	57	C C ₀	26 900 53 200	56 300 113 500	92 300 184 800	128 900 248 600	– –
		Slimline, long, high SLH (SLS) ⁴⁾ R1824 ... 60	57	C C ₀	33 300 70 000	69 700 149 300	119 200 256 600	165 000 345 300	265 500 525 600
Resist CR ¹⁾ runner blocks with aluminum end caps		Flanged, normal, standard height FNS R1851 ... 63	58	C C ₀	– ³⁾ – ³⁾	56 300 113 500	92 300 184 800	128 900 248 600	207 000 382 000
		Flanged, long, standard height FLS R1853 ... 63	58	C C ₀	– ³⁾ – ³⁾	69 700 149 300	119 200 256 600	165 000 345 300	265 500 525 600
		Slimline, normal, high SNH R1821 ... 63	58	C C ₀	– ³⁾ – ³⁾	56 300 113 500	92 300 184 800	128 900 248 600	– –
		Slimline, long, high SLH (SLS) ⁴⁾ R1824 ... 63	58	C C ₀	– ³⁾ – ³⁾	69 700 149 300	119 200 256 600	165 000 345 300	265 500 525 600
Resist CR ¹⁾ runner blocks for oil and grease lubrication from above		Flanged, normal, standard height FNS R1851 ... 66	59	C C ₀	26 900 53 200	56 300 113 500	92 300 184 800	128 900 248 600	207 000 382 000
		Flanged, long, standard height FLS R1853 ... 66	59	C C ₀	33 300 70 000	69 700 149 300	119 200 256 600	165 000 345 300	265 500 525 600
		Slimline, normal, high SNH R1821 ... 66	59	C C ₀	26 900 53 200	56 300 113 500	92 300 184 800	128 900 248 600	– –
		Slimline, long, high SLH R1824 ... 66	59	C C ₀	33 300 70 000	69 700 149 300	119 200 256 600	165 000 345 300	– –









1) Corrosion-resistant runner blocks, Resist CR, matte silver hard chrome plated, replace runner blocks with zinc-iron coating.

2) Basis for load capacities: The dynamic load capacities C are based on 100,000 m travel.

However, a travel of just 50,000 m is often taken as a basis. If this is the case, for comparison purposes: Multiply values C from the table by 1.23.

3) Size 25 in preparation

4) Size 65: Slimline, long, standard height SLS

Standard Resist CR ¹⁾ Runner Blocks			Page	Size	25	35	45	55	65
					Load capacities ²⁾ (N)				
Resist CR ¹⁾ runner blocks for central oil lubrication systems		Flanged, normal, standard height FNS R1851 ... 67	60	C C ₀	– –	56 300 113 500	92 300 184 800	128 900 248 600	– –
		Flanged, long, standard height FLS R1853 ... 67	60	C C ₀	– –	69 700 149 300	119 200 256 600	165 000 345 300	– –
		Slimline, normal, high SNH R1821 ... 67	60	C C ₀	– –	56 300 113 500	92 300 184 800	128 900 248 600	– –
		Slimline, long, high SLH R1824 ... 67	60	C C ₀	– –	69 700 149 300	119 200 256 600	165 000 345 300	– –
Resist CR ¹⁾ runner blocks for wall mounting		Flanged, normal, standard height FNS R1851 ... 68	61	C C ₀	– –	56 300 113 500	92 300 184 800	128 900 248 600	– –
		Flanged, long, standard height FLS R1853 ... 68	61	C C ₀	– –	69 700 149 300	119 200 256 600	165 000 345 300	– –
		Slimline, normal, high SNH R1821 ... 68	61	C C ₀	– –	56 300 113 500	92 300 184 800	128 900 248 600	– –
		Slimline, long, high SLH R1824 ... 68	61	C C ₀	– –	69 700 149 300	119 200 256 600	165 000 345 300	– –













1) Corrosion-resistant runner blocks, Resist CR, matte silver hard chrome plated, replace runner blocks with zinc-iron coating.

2) Basis for load capacities: The dynamic load capacities C are based on 100,000 m travel.

However, a travel of just 50,000 m is often taken as a basis. If this is the case, for comparison purposes: Multiply values C from the table by 1.23.

General Product Description

Product Overview with Rail Lengths

Guide Rails			Page	Size	25	35	45	55	65
					Maximum length per one-piece section (mm)				
Standard steel guide rails		R1805 .6. .. For mounting from above, with cover strip and screw-down protective caps	64		4 000	6 000 ²⁾	6 000 ²⁾	6 000 ²⁾	6 000 ²⁾
		R1805 .3. .. For mounting from above, with cover strip and strip clamp	66		4 000	6 000 ²⁾	6 000 ²⁾	6 000 ²⁾	6 000 ²⁾
		R1805 .2. .. For mounting from above, for cover strip	68		4 000	6 000 ²⁾	6 000 ²⁾	6 000 ²⁾	6 000 ²⁾
		R1805 .5. .. For mounting from above, with plastic mounting hole plugs	70		4 000	6 000 ²⁾	6 000 ²⁾	6 000 ²⁾	6 000 ²⁾
		R1806 .5. .. For mounting from above, for steel mounting hole plugs	72		4 000	6 000 ²⁾	6 000 ²⁾	6 000 ²⁾	6 000 ²⁾
		R1807 .0. .. For mounting from below	74		4 000	4 000	4 000	4 000	4 000
Standard Resist CR¹⁾ guide rails		R1845 .6. .. For mounting from above, with cover strip and screw-down protective caps	77		4 000	4 000	4 000	4 000	4 000
		R1845 .3. .. For mounting from above, with cover strip and strip clamp	77		4 000	4 000	4 000	4 000	4 000
		R1845 .7. .. For mounting from above, for cover strip	78		4 000	4 000	4 000	4 000	4 000
		R1845 .0. .. For mounting from above, with plastic mounting hole plugs	79		4 000	4 000	4 000	4 000	4 000
		R1846 .0. .. For mounting from above, for steel mounting hole plugs	80		4 000	4 000	4 000	4 000	4 000
		R1847 .0. .. For mounting from below	81		4 000	4 000	4 000	4 000	4 000
V-guide rails		R1808 .1. 3. Without mounting holes, for mounting with pressure pieces	84		–	4 000	4 000	4 000	4 000 ³⁾



1) Corrosion-resistant guide rails, Resist CR, matte silver hard chrome plated, replace guide rails with zinc-iron coating.





2) Maximum one-piece length up to 6000 mm only for special cases: The standard guide rail length is up to 4000 mm.

3) Size 65 in preparation

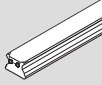
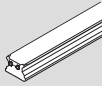
General Product Description

Product Overview with Load Capacities and Rail Lengths

Wide Roller Rail Systems			Page	Size	55/85	65/100
					Load capacities ²⁾ (N)	
Wide steel runner blocks		Wide, long, standard height BLS R1872 ... 10	92	C C ₀	165 000 345 300	265 000 525 600
Wide Resist CR ¹⁾ runner blocks		Wide, long, standard height BLS R1872 ... 60	92	C C ₀	165 000 345 300	265 000 525 600
					Maximum length per one-piece section (mm)	
Wide steel guide rails		R1875 .6 .. For mounting from above, with cover strip, screws and washers	94		4 000	6 000
Wide Resist CR ¹⁾ guide rails		R1873 .6 .. For mounting from above, with cover strip, screws and washers	94		4 000	4 000

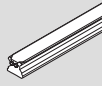
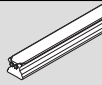
Heavy Duty Roller Rail Systems			Page	Size	100	125
					Load capacities ²⁾ (N)	
Heavy duty steel runner blocks		Flanged, normal, standard height FNS R1861 ... 10	100	C C ₀	461 000 811 700	757 200 1 324 000
		Flanged, long, standard height FLS R1863 ... 10	102	C C ₀	632 000 1 220 000	1 020 000 1 941 900
Heavy duty Resist CR ¹⁾ runner blocks		Flanged, normal, standard height FNS R1861 ... 60	100	C C ₀	461 000 811 700	757 200 1 324 000
		Flanged, long, standard height FLS R1863 ... 60	102	C C ₀	632 000 1 220 000	1 020 000 1 941 900
					Maximum length per one-piece section (mm)	
Heavy duty steel guide rails		R1835 .6 .. For mounting from above, with cover strip, screws and washers	104		3 900	2 900
Heavy duty Resist CR ¹⁾ guide rails		R1865 .6 .. For mounting from above, with cover strip, screws and washers	104		3 900	2 900

1) Corrosion-resistant runner blocks and guide rails in Resist CR, matte silver hard chrome plated, replace the runner blocks and guide rails with zinc-iron coating.

2) Basis for load capacities: The dynamic load capacities C are based on 100,000 m travel.

However, a travel of just 50,000 m is often taken as a basis. If this is the case, for comparison purposes: Multiply values C from the table by 1.23.

General Product Description

Combination Options

Rexroth profiled rail systems are no “off-the-peg” products.

They can be assembled in any desired combination for optimal customization to the user's specific application, true to our motto:

Make up your own compact linear motion guideways from interchangeable standard stock elements...

Modular design at its best.

Standard runner blocks

Flanged, normal, standard height FNS

Steel:

R1851 ... 10

R1851 ... 13 with aluminum end caps

R1851 ... 16 for oil and grease lubrication from above

R1851 ... 17 for central oil lubrication systems

R1851 ... 18 for wall mounting

Resist CR¹⁾:

R1851 ... 6. (last digit same as in corresponding steel runner block)

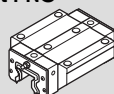

Flanged, long, standard height FLS

Steel:

R1853 ... 10

R1853 ... 13 with aluminum end caps

R1853 ... 16 for oil and grease lubrication from above

R1853 ... 17 for central oil lubrication systems

R1853 ... 18 for wall mounting

Resist CR¹⁾:

R1853 ... 6. (last digit same as in corresponding steel runner block)

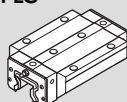

Slimline, normal, high SNH

Steel:

R1821 ... 10

R1821 ... 13 with aluminum end caps

R1821 ... 16 for oil and grease lubrication from above

R1821 ... 17 for central oil lubrication systems

R1821 ... 18 for wall mounting

Resist CR¹⁾:

R1821 ... 6. (last digit same as in corresponding steel runner block)

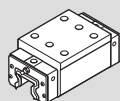

Slimline, long, high SLH

Steel:

R1824 ... 10

R1824 ... 13 with aluminum end caps

R1824 ... 16 for oil and grease lubrication from above

R1824 ... 17 for central oil lubrication systems

R1824 ... 18 for wall mounting

Resist CR¹⁾:

R1824 ... 6. (last digit same as in corresponding steel runner block)

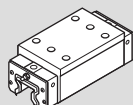

...can be combined with...

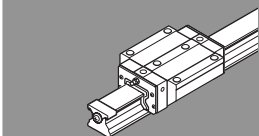

to form a complete guideway unit.

Standard guide rails

For mounting from above,
with cover strip and
screw-down protective caps

R1805 .6. ..

Steel

R1845 .6. ..

Resist CR¹⁾

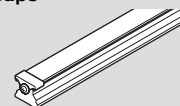

For mounting from above,
with cover strip and strip clamp

R1805 .3. ..

Steel

R1845 .3. ..

Resist CR¹⁾

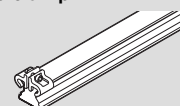

For mounting from above,
for cover strip

R1805 .2. ..

Steel

R1845 .7. ..

Resist CR¹⁾

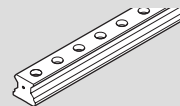

For mounting from above,
with plastic mounting hole plugs

R1805 .5. ..

Steel

R1845 .0. ..

Resist CR¹⁾

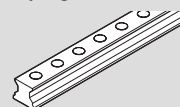

For mounting from above,
for steel mounting hole plugs

R1806 .5. ..

Steel

R1846 .0. ..

Resist CR¹⁾

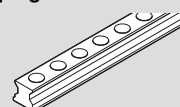

For mounting from below

R1807 .0. ..

Steel

R1847 .0. ..

Resist CR¹⁾

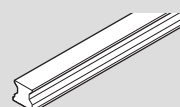

V-guide rails

Without mounting holes,
for mounting with pressure pieces

R1808 .1. 3.

Steel

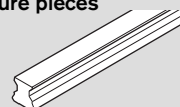

1) Corrosion-resistant runner blocks and guide rails in Resist CR, matte silver hard chrome plated, replace the runner blocks and guide rails with zinc-iron coating.

Wide runner blocks

Wide, long, standard height BLS

R1872 ... 10

Steel

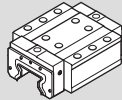

R1872 ... 60

Resist CR¹⁾

...can be combined with...

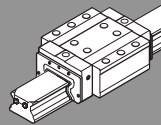

to form a complete guideway unit.

Wide guide rails

For mounting from above,
with cover strip, screws and washers

R1875 .6. ..

Steel

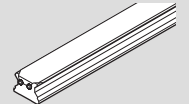

R1873 .6. ..

Resist CR¹⁾

Heavy duty runner blocks

Flanged, normal, standard height FNS

R1861 ... 10

Steel

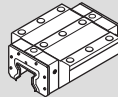

R1861 ... 60

Resist CR¹⁾

...can be combined with...

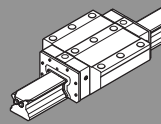

to form a complete guideway unit.

Heavy duty guide rails

For mounting from above,
with cover strip, screws and washers

R1835 .6. ..

Steel

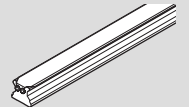

R1865 .6. ..

Resist CR¹⁾

Flanged, long, standard height FLS

R1863 ... 10

Steel

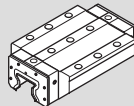

R1863 ... 60

Resist CR¹⁾

1) Corrosion-resistant runner blocks and guide rails in Resist CR, matte silver hard chrome plated, replace the runner blocks and guide rails with zinc-iron coating.

General Product Description

General Technical Data and Calculations

General Notes

The general technical data and calculations apply to all Roller Rail Systems, i.e., to all runner blocks and guide rails.

Special technical data relating to the individual runner blocks and guide rails is given separately.

Preload classes

To cater for the widest possible range of applications Rexroth roller runner blocks (RB) are provided in different preload classes.

To prevent any reduction of service life, the preload should not exceed 1/3 of the bearing load F.

The following preload classes are available as standard:

- RB with preload 8% C (preload class C2)
- RB with preload 13% C (preload class C3)

In general, the rigidity of the runner block rises with increasing preload.

Special version on request:

- RB with preload 3% C (preload class C1)
- RB with preload >13% C (example: 17% C)

Guides with parallel rails

In addition to the preload class, the permissible parallelism offset of the rails must also be taken into account (see "Selection of Accuracy Classes").

Speed

$$v_{\max} = 3^1) \text{ m/s}$$

Speeds of up to 4 m/s are possible. Service life is limited by wear of plastic parts.

1) Sizes 100 and 125: 2 m/s

Acceleration

$$a_{\max} = 150 \text{ m/s}^2$$

Requirement:
The Roller Rail System must always be preloaded, even when operated under load!

Operating temperature range

$$-10 \text{ }^\circ\text{C} \dots 80 \text{ }^\circ\text{C}$$

Brief peaks up to 100°C are permissible.

For even lower sub-zero temperatures, please consult us.

Friction

The table lists reference values for the frictional force in a sealed and lubricated complete runner block.

When the runner block starts to move, the frictional force can be 1.5 to 2 times the given value, depending on the length of time it has been at a standstill, as well as the type, quantity and condition of the lubricant, and the amount of dirt that has accumulated on the guide rail. This applies to all runner blocks in all preload classes.

Size	Frictional drag F_R (N)
25	30
35	40
45	60
55	70
65	90
55/85	70
65/100	90
100	approx. 400 ¹⁾
125	600 ¹⁾

1) Directly after lubrication, the frictional drag will be approx. 50% higher.

The friction coefficient μ is approx. 0.0004 to 0.001 (excluding seal friction).

Seals/scrapers

Additional seals and scrapers are intended to prevent dirt, chips, etc. from entering the runner block and to avoid premature termination of its useful life.

Standard version: Internal universal seal and end seal

Universal seals and end seals are standard built-in features of Rexroth runner blocks. They provide uniform sealing efficiency on guide rails with and without cover strip.

Viton or NBR wiper seals

Wiper seals made from Viton or NBR are optional accessories to be fitted by the customer.

Viton or NBR seals

- For use in environments heavily soiled with fine dirt or metal particles
- In applications involving the use of coolants or cutting fluids in addition to the presence of dirt and metal particles, only Viton seals should be used.
- Replaceable
- Two-piece version

Metal scrapers

Metal scrapers with spacer plates are optional accessories to be fitted by the customer.

Metal scrapers with spacer plates

- For use in environments with hot metal chips or welding splatter.

General Product Description

General Technical Data and Calculations

Forces and load moments

In Rexroth Roller Rail Systems the running tracks are arranged at a compression angle of 45°.

This results in the same high load capacity of the entire system in all four major planes of load application. The runner blocks may be subjected to both forces and load moments.

Forces in the four major planes of load application

- Pull F_z (positive z-direction)
- Push $-F_z$ (negative z-direction)
- Side load F_y (positive y-direction)
- Side load $-F_y$ (negative y-direction)

Moment loads

- Moment M_x (about the x-axis)
- Moment M_y (about the y-axis)
- Moment M_z (about the z-axis)

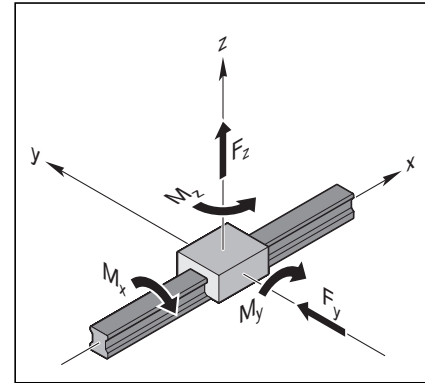

Definition of load capacities

Dynamic load capacity C

The radial loading of constant magnitude and direction which a linear rolling bearing can theoretically endure for a nominal life of 10^5 meters distance traveled (as per ISO 14728 Part 1).

Note:

The dynamic load capacities given in the tables are mostly 20% above the DIN or ISO values. They have been proven in tests.

Static load capacity C_0

Static load in the load direction that corresponds to a calculated load in the center of the contact point with the greatest load between the rolling element and track zone (guide rail) of 4000 MPa.

Note:

With this load on the contact point, a permanent overall deformation of the rolling element and track zone occurs, corresponding to around 0.0001 times the roller body diameter (as per ISO 14728 Part 1).

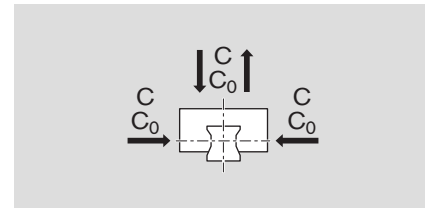

Definition of moment load capacities

Dynamic torsional moment load capacity M_t

Comparative dynamic moment about the longitudinal axis x which causes a load equivalent to the dynamic load capacity C.

Static torsional moment load capacity M_{t0}

Comparative static moment about the longitudinal axis x which causes a load equivalent to the static load capacity C_0 .

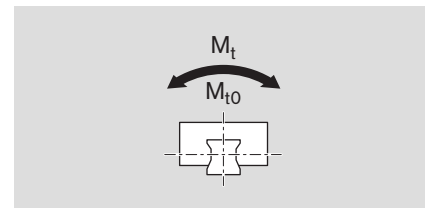

Dynamic longitudinal moment load capacity M_L

Comparative dynamic moment about the transverse axis y or the vertical axis z which causes a load equivalent to the dynamic load capacity C.

Static longitudinal moment load capacity M_{L0}

Comparative static moment about the transverse axis y or the vertical axis z which causes a load equivalent to the dynamic load capacity C_0 .

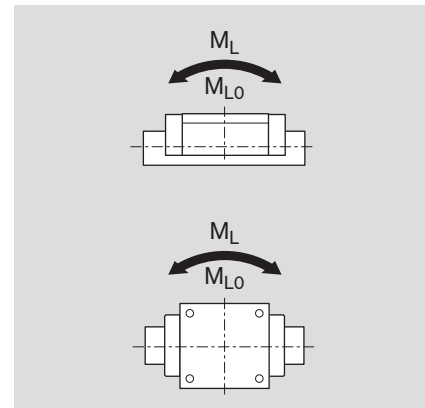

Definition and calculation of the nominal life

The calculated service life which an individual linear rolling bearing, or a group of apparently identical rolling element bearings operating under the same conditions, can attain with a 90% probability, with contemporary, commonly used materials and manufacturing quality under conventional operating conditions (to ISO 14728 Part 1) and optimal installation conditions.

If 90% probability is not sufficient, the nominal life values must be reduced by the factor a_1 as given in the table below.

Probability %	Factor a_1
90	1.00
95	0.62
96	0.53
97	0.44
98	0.33
99	0.21

Nominal life in meters

$$(1) L_{10} = \left(\frac{C}{F_m} \right)^3 \cdot 10^5 \text{ m}$$

L_{10} = nominal life (m)
 C = dynamic load capacity (N)
 F_m = equivalent dynamic load on the bearing (N)

Service life in operating hours at constant stroke length and stroke frequency

If the stroke length s and the stroke frequency n are constant throughout the service life, the service life in operating hours can be calculated using formula (2).

$$(2) L_{h 10} = \frac{L_{10}}{2 \cdot s \cdot n \cdot 60}$$

L_{10} = nominal life (m)
 $L_{h 10}$ = nominal life (h)
 s = length of stroke (m)
 n = stroke repetition rate (full cycles) (min^{-1})

Service life in operating hours at average speed

Alternatively, the service life in operating hours at average speed v_m can be calculated using formula (3).

$$(3) L_{h 10} = \frac{L_{10}}{60 \cdot v_m}$$

L_{10} = nominal life (m)
 $L_{h 10}$ = nominal life (h)
 v_m = average speed (m/min)

When the speed is varied in steps, this average speed v_m is calculated using the discrete time steps q_{tn} of the individual load levels (4).

v_m = average speed (m/min)
 $v_1 \dots v_n$ = discrete speed steps (m/min)
 $q_{t1} \dots q_{tn}$ = discrete time steps for $v_1 \dots v_n$ (%)

$$(4) v_m = \frac{q_{t1} \cdot |v_1| + q_{t2} \cdot |v_2| + \dots + q_{tn} \cdot |v_n|}{100 \%}$$

Notes

ISO 14728 Part 1 limits the applicability of formula (1) to equivalent dynamic loads $F_m < 0.5 C$.

However, our tests have demonstrated that – under ideal operating conditions – this nominal life formula can be applied to loads of $F_m = C$.

For stroke lengths less than $2 \cdot$ runner block length B_1 (see dimension tables), a reduction in load capacity may have to be taken into account. Please consult us.

General Product Description

General Technical Data and Calculations

Load on bearings for calculation of nominal life

Recommended minimum load ratios

$$\text{Dynamic load ratio} = \frac{C}{F_{m, \max}}$$

$$\text{Static load ratio} = \frac{C_0}{F_{\text{eff}, \max}}$$

Note

In general, the load ratio should not fall below the minimum value of 4.0 for both dynamic and static loads. A higher load ratio is always required in applications requiring high rigidity and/or long life.

For pulling loads, the strength of the screws must be verified. Please refer to the "Mounting Instructions" section.

Combined equivalent load on bearing

With formula (5) all of the partial loads in a particular load case can be factored in to calculate the combined equivalent load on the bearing.

Notes

The calculation of the moment loads as shown in formula (5) applies only for applications with one single rail and one runner block. The formula is simpler for other combinations.

The forces and load moments shown in the coordinate system can also act in the opposite direction.

An external load acting at an angle on the runner block is to be broken down into its F_y and F_z components, and these values are then to be used in formula (5). The structure of the runner blocks allows this simplified calculation.

$$(5) F_{\text{comb}} = |F_y| + |F_z| + C \cdot \frac{|M_x|}{M_t} + C \cdot \frac{|M_y|}{M_L} + C \cdot \frac{|M_z|}{M_L}$$

- F_{comb} = combined equivalent load on bearing (N)
- $F_{m, \max}$ = largest effective equivalent load on bearing (N)
- $F_{\text{eff}, \max}$ = maximum load occurring during the travel cycle (N)
- F_y = external load due to a resulting force in the y-direction (N)

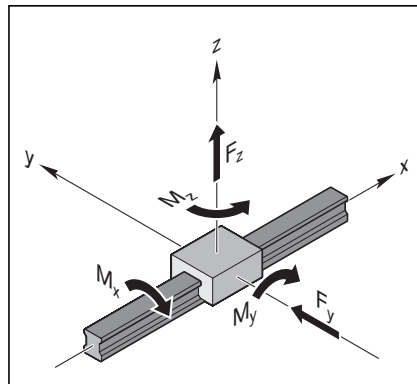

Allowance for internal preload force F_{pr}

To increase the rigidity and accuracy of the guide system preloaded runner blocks should be used (see also "Selection of System Preload").

When runner blocks in preload classes C2 and C3 are used, it may be necessary to take the internal preload force into account since the two rows of rollers a and b are designed to be oversized and are therefore preloaded against each other with an internal preload force F_{pr} which causes them to deflect by the amount δ_{pr} (see chart).

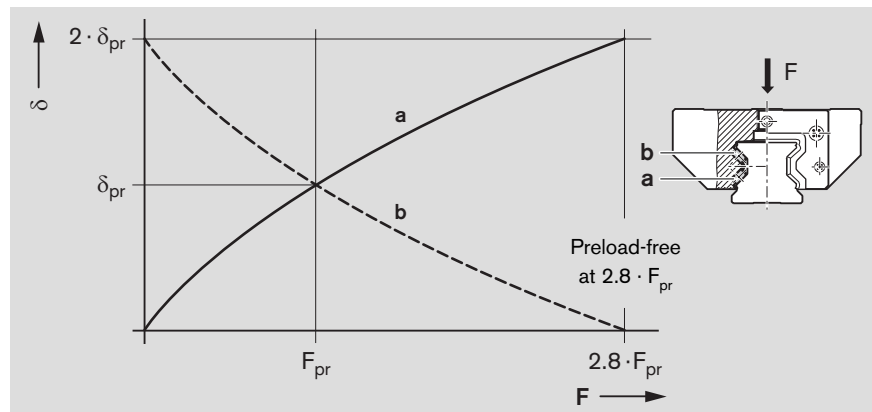

- a = loaded (lower) row of rollers
- b = non-loaded (upper) row of rollers
- δ = deflection of rollers at F
- δ_{pr} = deflection of rollers at F_{pr}
- F = load on the runner block
- F_{pr} = internal preload force

Effective equivalent load on bearing

When an external load reaches 2.8 times the internal preload force F_{pr} , one row of rollers becomes preload-free.

Note

For highly dynamic load cases, the combined equivalent load on the bearings should be $F_{comb} < 2.8 \cdot F_{pr}$ in order to avoid damage to the roller bearings due to slip.

2 different cases should be considered:

Case 1: $F_{comb} > 2.8 \cdot F_{pr}$

In case 1, the internal preload force F_{pr} has no effect on the service life:

$$(6) \quad F_{eff} = F_{comb}$$

Case 2: $F_{comb} \leq 2.8 \cdot F_{pr}$

In case 2 the preload force F_{pr} is factored into the calculation of the effective

$$(7) \quad F_{eff} = \left(\frac{F_{comb}}{2.8 \cdot F_{pr}} + 1 \right)^{\frac{3}{2}} \cdot F_{pr}$$

- F_{comb} = combined equivalent load on bearing (N)
- F_{eff} = effective equivalent load on bearing (N)
- F_{pr} = preload force (N)
- F_{pr} = 8% C (at preload class C2)
- F_{pr} = 13% C (at preload class C3)

Equivalent dynamic load on bearing

For varying load levels, calculate the equivalent dynamic load on the bearings using formula (8).

$$(8) \quad F_m = \sqrt[3]{(F_{eff1})^{\frac{10}{3}} \cdot \frac{q_{s1}}{100\%} + (F_{eff2})^{\frac{10}{3}} \cdot \frac{q_{s2}}{100\%} + \dots + (F_{effn})^{\frac{10}{3}} \cdot \frac{q_{sn}}{100\%}}$$

- F_m = equivalent total dynamic load on bearing (N)
- $F_{eff1} \dots F_{effn}$ = uniform effective single loads (m/min)
- $q_{s1} \dots q_{sn}$ = discrete travel steps for $F_{eff1} \dots F_{effn}$ (%)

Equivalent static load on bearing

For combined static external loads – vertical and horizontal – in conjunction with a static torsional or longitudinal moment load, calculate the equivalent static bearing on the load $F_{0\ comb}$ using formula (9).

$$(9) \quad F_{0\ comb} = |F_{0y}| + |F_{0z}| + C_0 \cdot \frac{|M_{0x}|}{M_{t0}} + C_0 \cdot \frac{|M_{0y}|}{M_{L0}} + C_0 \cdot \frac{|M_{0z}|}{M_{L0}}$$

- $F_{0\ comb}$ = static equivalent load on bearing (N)
- F_{0y} = external static load due to a force in the y-direction (N)
- F_{0z} = external static load due to a force in the z-direction (N)
- C_0 = static load capacity¹⁾ (N)
- M_{t0} = static torsional moment load capacity¹⁾ (Nm)
- M_{L0} = static longitudinal moment load capacity¹⁾ (Nm)
- M_{0x} = load due to a static moment load about the x-axis (Nm)
- M_{0y} = load due to a static moment load about the y-axis (Nm)
- M_{0z} = load due to a static moment load about the z-axis (Nm)

Notes

The equivalent static load on the bearing $F_{0\ comb}$ must not exceed the static load capacity C_0 . Formula (9) only applies if a single guide rail is used.

An external load acting at an angle on the runner block is to be broken down into its F_{0y} and F_{0z} components, and these values are then to be used in formula (9).

1) See tables for values

General Product Description

Selection of Accuracy Classes

Accuracy classes and their tolerances for Standard and Heavy Duty Roller Rail Systems

Standard roller rail systems are offered in up to five different accuracy classes, and heavy duty roller rail systems in up to three accuracy classes. For details of the available runner blocks and guide rails, see the "Part numbers" tables.

Built-in interchangeability through precision machining

Rexroth manufactures its guide rails and runner blocks with such high precision, especially in the roller track zone, that each individual component element can be replaced by another at any time. For example, a runner block can be used without problems on various guide rails of the same size. This applies equally to the use of different runner blocks on one and the same guide rail.

Abbreviations

RB/GR = runner block and guide rail hard chrome plated
 GR = only guide rail hard chrome plated

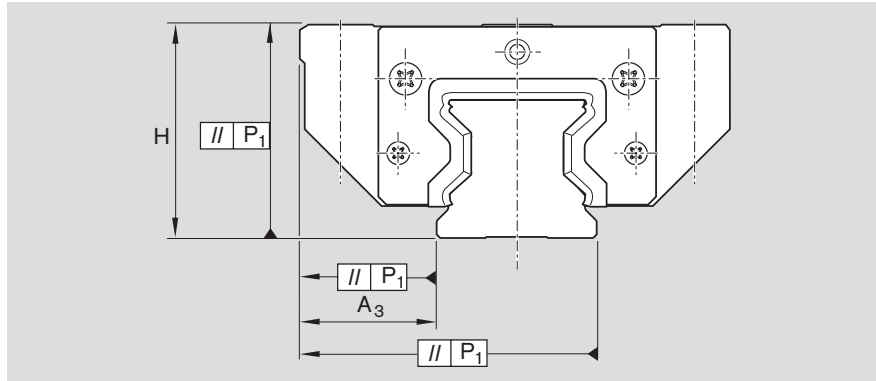

Standard and heavy duty roller rail systems, steel version

Accuracy classes	Dimensional tolerances (µm)		Max. difference in dimension H and A ₃ on one guide rail (µm) ΔH, ΔA ₃
	H	A ₃	
H	±40	±20	15
P	±20	±10	7
SP	±10	±7	5
GP ¹⁾	(±10) 10	±7	5
UP	±5	±5	3

1) Dimension H: (±10) sorted by height (GP) to 10 µm (see "Combination of Accuracy Classes")

Standard and heavy duty RRS Resist CR, matte silver hard chrome plated

	H		RB/GR	A ₃	RB/GR	ΔH, ΔA ₃
	RB/GR	GR				
H	+47	+44	±23	+19	18	15
	-38	-39				
P	+27	+24	±13	+9	10	7
	-18	-19				
SP	+17	+14	±10	+6	8	5
	-8	-9				

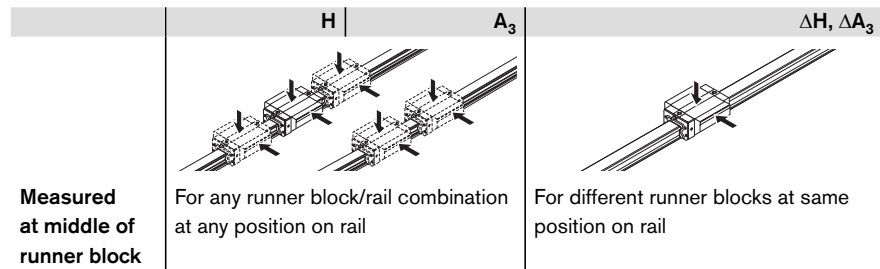

Parallelism offset P₁ of the roller rail system in service

Values measured at middle of runner block for roller rail systems without surface coating.

For hard chrome plated guide rails the values may increase by up to 2 µm.

Key to graph

P₁ = parallelism offset (µm)
 L = rail length (mm)

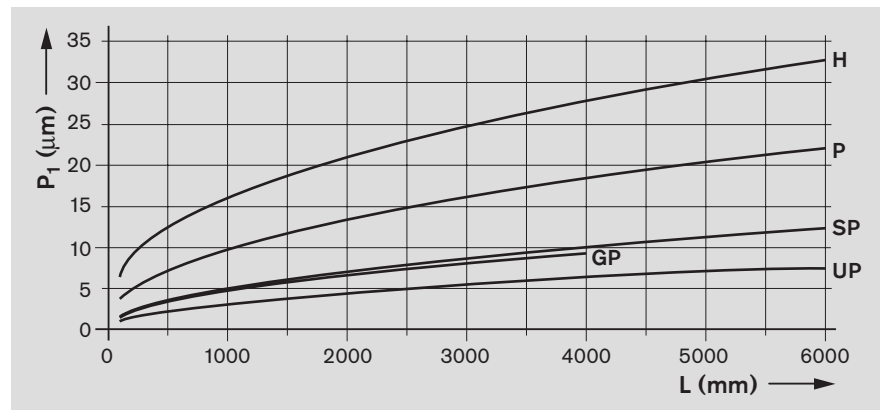

Accuracy classes and their tolerances for Wide Roller Rail Systems

Wide roller rail systems are offered in up to three different accuracy classes. For details of the available runner blocks and guide rails, see the "Part numbers" tables.

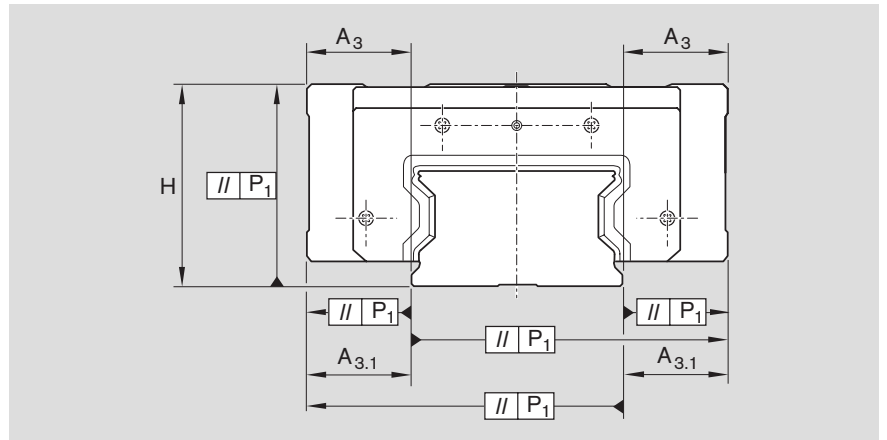

Wide roller rail systems, steel version

Accuracy classes	Dimensional tolerances (µm)			Max. difference in dimension H and A ₃ on one guide rail (µm)	
	H	A ₃	A _{3.1}	ΔH, ΔA ₃	ΔA _{3.1}
H	±40	±20	+26/-24	15	17
P	±20	±10	+15/-13	7	9
SP	±10	±7	+12/-10	5	7

Wide roller rail systems, Resist CR, matte silver hard chrome plated

	H		A ₃		A _{3.1}		ΔH, ΔA ₃		ΔA _{3.1}	
	RB/GR	GR	RB/GR	GR	RB/GR	GR	RB/GR	GR	RB/GR	GR
H	+47	+44	±23	+19	+29	+25	18	15	20	17
	-38	-39		-24	-27	-28				
P	+27	+24	±13	+9	+18	+14	10	7	12	9
	-18	-19		-14	-16	-17				
SP	+17	+14	±10	+9	+18	+14	10	7	12	9
	-8	-9		-14	-16	-17				

Abbreviations

RB/GR = runner block and guide rail hard chrome plated
 GR = only guide rail hard chrome plated

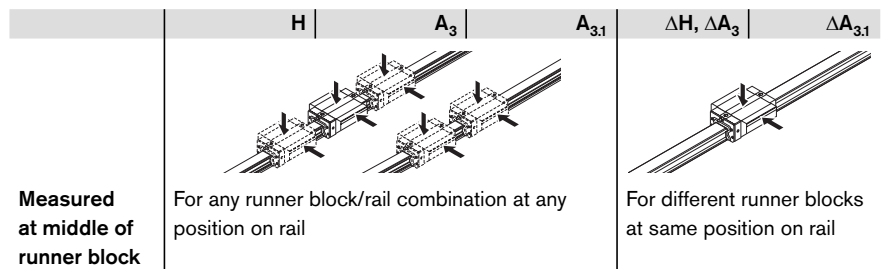

Parallelism offset P₁ of the roller rail system in service

Values measured at middle of runner block for roller rail systems without surface coating.

For hard chrome plated guide rails the values may increase by up to 2 µm.

Key to graph

P₁ = parallelism offset (µm)
 L = rail length (mm)

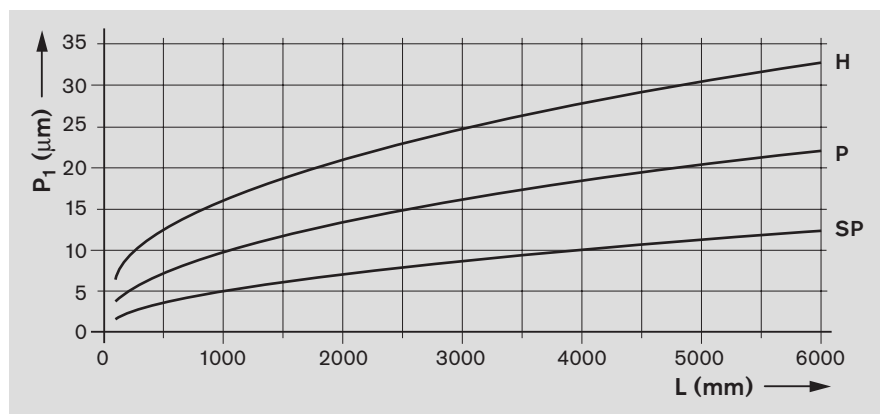

General Product Description

Selection of Accuracy Classes

Combination of accuracy classes

Accuracy classes		Guide rail class				
Runner block class	Dimensional tolerances	H μm	P μm	SP μm	GP μm	UP μm
H	Tolerance for dimension H	±40	±24	±15	-	±11
	Tolerance for dimension A ₃	±20	±14	±12	-	±11
	Max. difference in dimension H and A ₃ on one rail	15	15	15	-	15
P	Tolerance for dimension H	±36	±20	±11	-	±7
	Tolerance for dimension A ₃	±16	±10	±8	-	±7
	Max. difference in dimension H and A ₃ on one rail	7	7	7	-	7
SP	Tolerance for dimension H	±35	±19	±10	(±10) ¹⁾ ±5	±6
	Tolerance for dimension A ₃	±15	±9	±7	±7	±6
	Max. difference in dimension H and A ₃ on one rail	5	5	5	5	5
UP	Tolerance for dimension H	±34	±18	±9	±4	±5
	Tolerance for dimension A ₃	±14	±8	±6	±6	±5
	Max. difference in dimension H and A ₃ on one rail	3	3	3	3	3

1) Dimension H: (±10) sorted by height (GP) to 10 μm (see "Combination: Runner block SP with guide rail GP")

Combination: Runner block SP with guide rail GP

Tolerances for dimension H

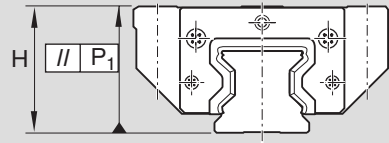

Measured at middle of runner block over the entire rail length

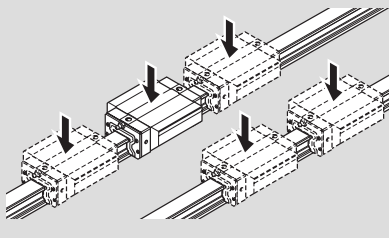

Dimension H (±10) sorted by height (GP) to ±5 ... 10 μm:

Applies for any combination of runner blocks with accuracy class SP and guide rails R1805 .68 .. with the same sorting dimension, e.g. -1^{±2.5} μm, over the entire rail length.

Sorting code on the guide rail and the additional label, e.g. GP -1, GP +3, etc.

When ordering, please state the quantity per sorting dimension, e.g. 2 pcs per sorting dimension.

Height sorting of the guide rails

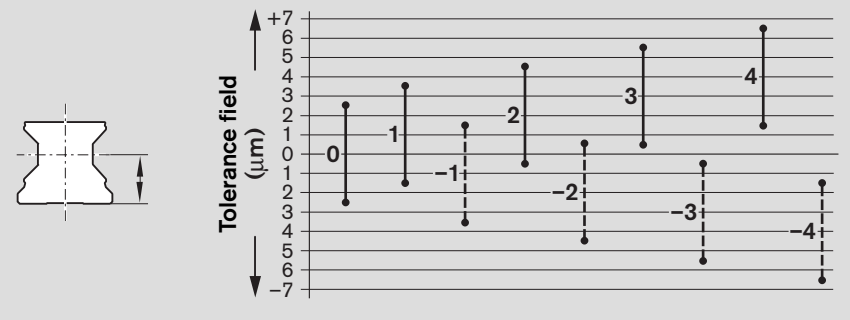

Recommendations for combining accuracy classes

Recommended for **close spacing of runner block** and short strokes:
Runner block in higher accuracy class than guide rail.

Recommended for **larger runner block spacing** and long strokes:
Guide rail in higher accuracy class than runner block.

Caution!

For runner blocks and guide rails in Resist CR, matte silver hard chrome plated, different tolerances apply for the dimensions H and A₃ (see "Accuracy classes and their tolerances").

Travel accuracy

Perfected roller entry and exit zones in the runner blocks and optimized spacing of the mounting screws provide unmatched travel accuracy with very low pulsation.

These high accuracy systems are especially suitable for high-precision machining processes, measurement systems, high-precision scanners, EDM equipment, etc.

General Product Descriptions

Selection of System Preload

Definition of the preload class

Preloading force relative to the dynamic load capacity C of the respective runner block.

Example

- Runner block FNS R1851 423 10
- Preload class C2
- Dynamic load capacity $C = 92,300$ N (value taken from runner block table)

Calculation:

$$C2 = 8\% C = 7384 \text{ N}$$

This runner block is preloaded with a base load of 7384 N.

Selection of the preload class

Code	Preload	Application area
C1	3% C	Special version on request
C2	8% C	For precise guide systems with both high external loading and high demands on overall rigidity; also recommended for single rail systems. Above average moment loads can be absorbed without significant elastic deflection. Further improved overall rigidity with only medium moment loads.
C3	13% C	For highly rigid guide systems such as precision machine tools, etc. Above average loads and moments can be absorbed with the least possible elastic deflection. Runner blocks with preload C3 available in accuracy classes P, SP (GP) and UP only.

Recommended preload for roller runner blocks

Preference should be given to runner blocks with preload C2.

Runner blocks with preload C1 are available on request (special versions).

Recommended preload and accuracy class combinations

Recommended for preload C2:
Accuracy classes H and P

Recommended for preload C3:
Accuracy classes P and SP (GP)

Combination of hard chrome plated runner blocks with hard chrome plated guide rails

When hard chrome plated runner blocks with preload $C2 = 8\% C$ (or $C3 = 13\% C$) are combined with hard chrome plated guide rails, the preload increases to approx. $10\% C$ (or approx. $15\% C$).

Standard Runner Blocks, Steel version

Product Description

Outstanding features

- Standard runner blocks are suitable for all typical applications.
- Runner blocks can also be supplied for special conditions of installation and use and for special working environments.
- High torque capacity
- Same high load capacities in all four major planes of load application
- Highest rigidity in all load directions when additional mounting screws are used in two holes provided at the center of the runner block.
- Unrestricted interchangeability
- Unlimited combinability: any guide rail version can be paired with any runner block version.
- Accessories can be simply attached to the ends of the runner block.
- Mounting of attachments to runner block from above or below

Further highlights

- Lube ports on all sides for maximum ease of maintenance
- Novel lube duct design minimizes lubricant consumption.
- Runner blocks made from antifriction bearing steel, with hardened and ground raceways
- Smooth running thanks to optimized roller recirculation and guidance
- Optimized entry-section geometry and high number of rollers per track minimizes variation in elastic deflection.
- The runner block simply slides off its arbor and onto the rail.
- End seals integrated as standard for better sealing of all running tracks and to protect plastic parts

Standard Roller Rail System (example)

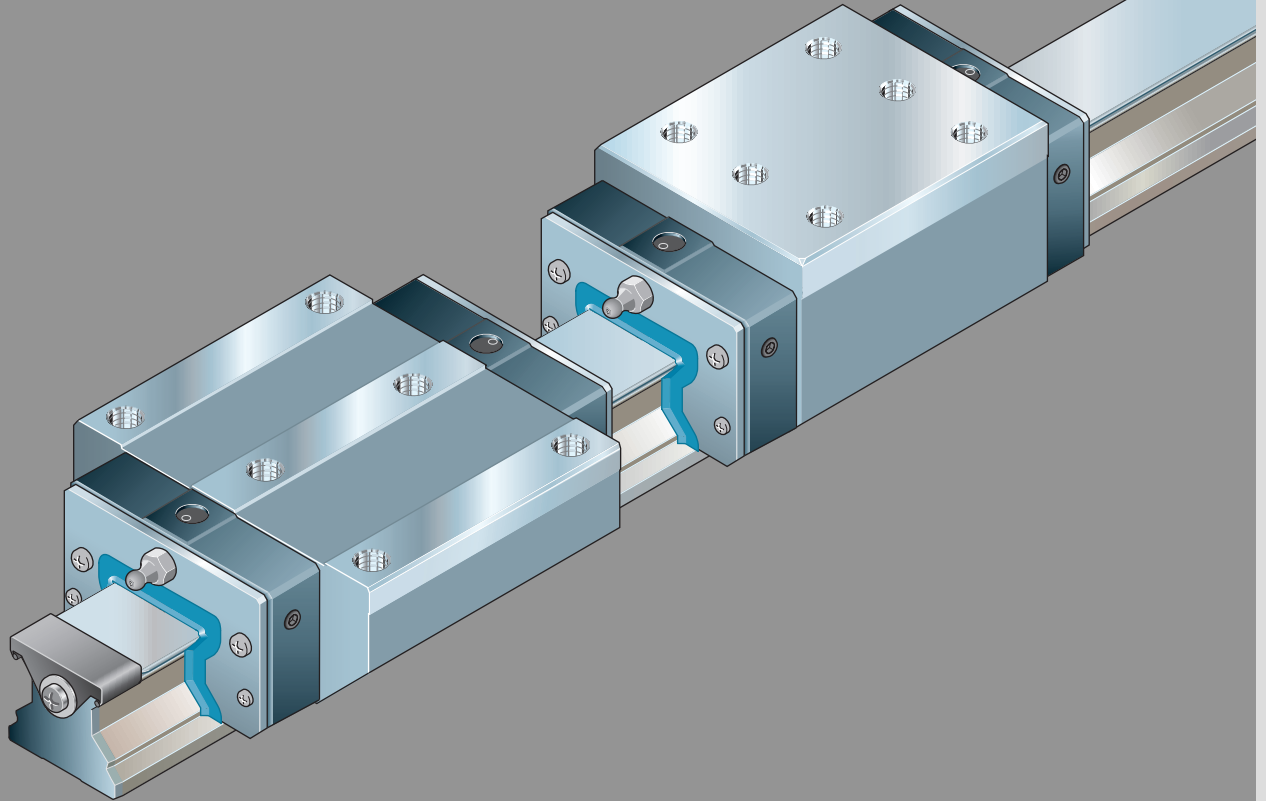

Material specifications

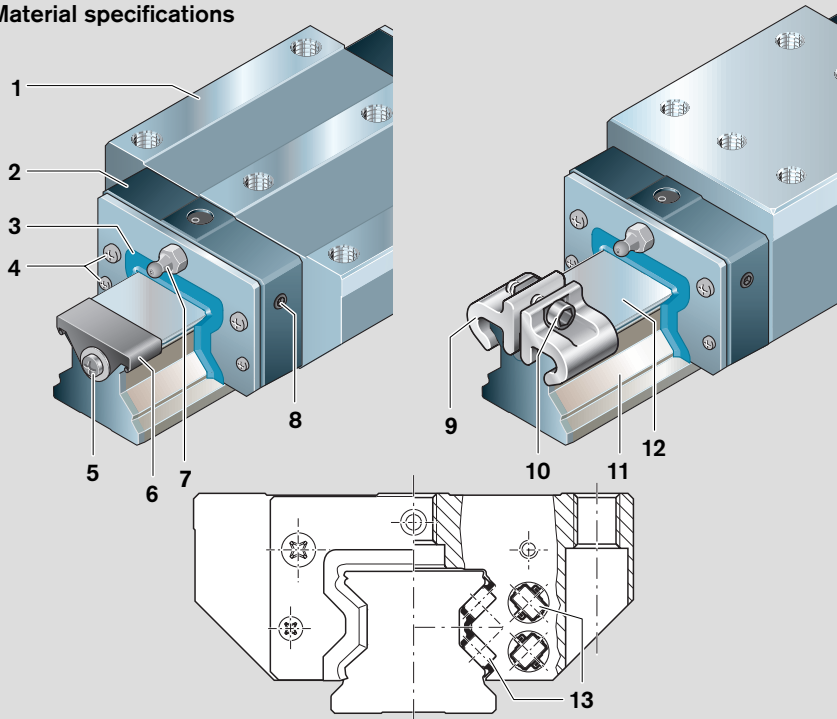

- 1 Runner block body: antifriction bearing steel
- 2 End cap: plastic (alternative: aluminum)
- 3 End seal: 1.4301 (corrosion-resistant spring steel to EN 10088) with polymer seal
- 4 Mounting screws: stainless steel A2
- 5 Screw: stainless steel A2
Washer: galvanized steel
- 6 Protective cap: plastic
- 7 Lube nipple: galvanized carbon steel
- 8 Screw plug: carbon steel (side lube hole)
- 9 Strip clamp: anodized aluminum
- 10 Clamping screw/nut: 1.4301
- 11 Guide rail: heat-treatable steel
- 12 Cover strip: 1.4301
- 13 Rollers: antifriction bearing steel

Standard Runner Blocks, Steel version

Product Description

Runner blocks

Standard runner blocks are suitable for almost all applications.

FNS R1851 ... 10

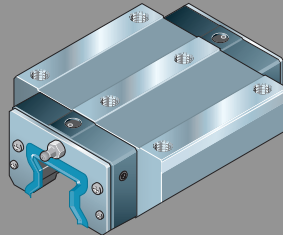

SNH R1821 ... 10

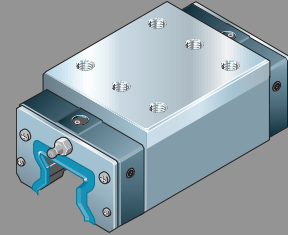

FLS R1853 ... 10

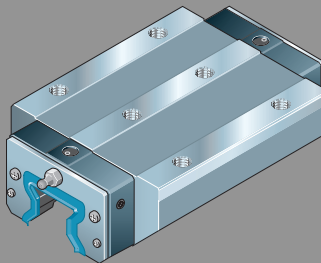

SLH R1824 ... 10

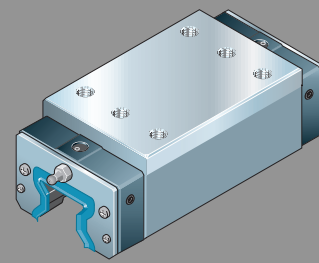

Runner blocks with aluminum end caps

Special feature:
These runner blocks are recommended for especially demanding conditions of use.

FNS R1851 ... 13

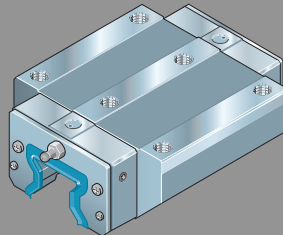

SNH R1821 ... 13

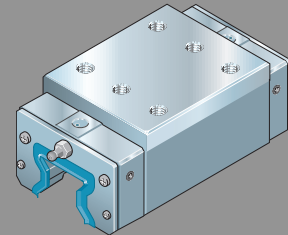

FLS R1853 ... 13

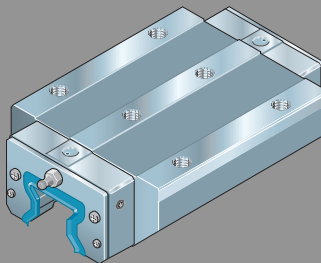

SLH R1824 ... 13

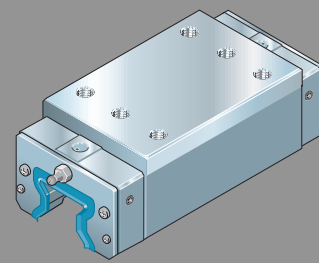

Runner block short names

FNS = Flanged, normal, standard height
FLS = Flanged, long, standard height
SNH = Slimline, normal, high
SLH = Slimline, long, high

Options

Corrosion-resistant runner blocks,
Resist CR, matte silver hard chrome
plated, see section on "Standard
Runner Blocks, Resist CR".

Runner Blocks for oil and grease lubrication from above

Special feature:

Runner blocks R18.. ... 16 have been prepared for oil and grease lubrication from above. In the high runner blocks S.H, the vertical clearance between the end caps and an attachment mounting surface with integrated lube adapters has been designed for ease of maintenance.

How to recognize them:

The top lube holes at both ends have already been opened, but they are closed with screws for shipment (O-rings for sealing the lube fittings are provided with the runner blocks).

FNS R1851 ... 16

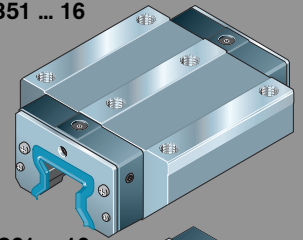

SNH R1821 ... 16

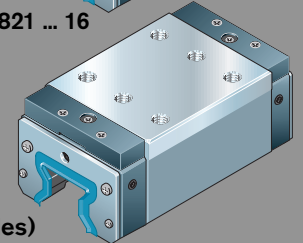

(Examples)

Runner blocks (exclusively) for central oil lubrication via dosing

Special feature:

Runner blocks R18.. ... 17 have smaller lube ducts. They need only small quantities of lube oil even when wall-mounted and are therefore suitable for all mounting orientations.

How to recognize them:

The end caps are gray. In the high runner blocks S.H, the vertical clearance between the end caps and an attachment mounting surface with integrated lube adapters has been designed for ease of maintenance.

The top lube holes at both ends have already been opened, but they are closed with screws for shipment (O-rings for sealing the lube fittings are provided with the runner blocks).

FNS R1851 ... 17

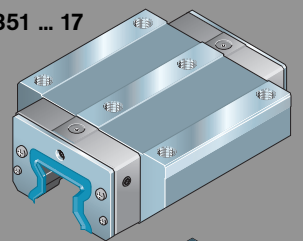

SNH R1821 ... 17

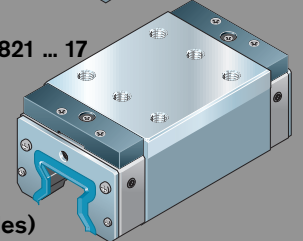

(Examples)

Runner blocks for wall mounting

Special feature:

Runner blocks R18.. ... 18 are especially suitable for wall mounting. For lubrication, both lube holes on the end face must be used – to ensure proper lubrication of the upper and lower raceways.

For short-stroke applications, lubricant must be applied to all (four) lube holes.

How to recognize them:

The runner blocks have two lube holes at each end face for oil lubrication.

Runner blocks size 65 (only)

Special feature:

The runner block FLS R1859 620 31 for wall mounting is available in size 65 (only) with accuracy class SP and preload class C3 (13% C).

Lube fittings must be attached at both ends faces (a) or at both ends of the attachment mounting surface (b) – to ensure proper lubrication of the upper and lower raceways.

The side holes (c) cannot be used!

The dimensions, load capacities, rigidity and moment loads correspond to those of standard runner block FLS R1853 631 10.

How to recognize them:

The end caps are blue.

FNS R1851 ... 18
(Example)

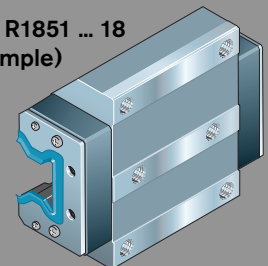

FLS R1859 620 31

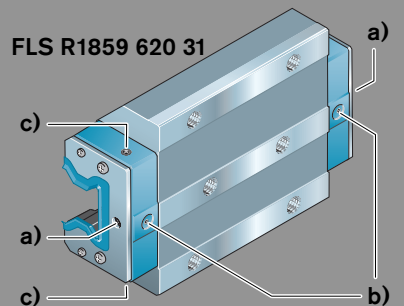

Standard Runner Blocks, Steel version

Rigidity

Rigidity of the roller rail system at preload C2

Standard runner block FNS R1851

Sizes 25 to 65

measured values

Runner block mounted using 6 screws:

- 4 outer screws of strength class 12.9
- 2 centerline screws of strength class 8.8

1. Down load

2. Lift-off load

3. Side load

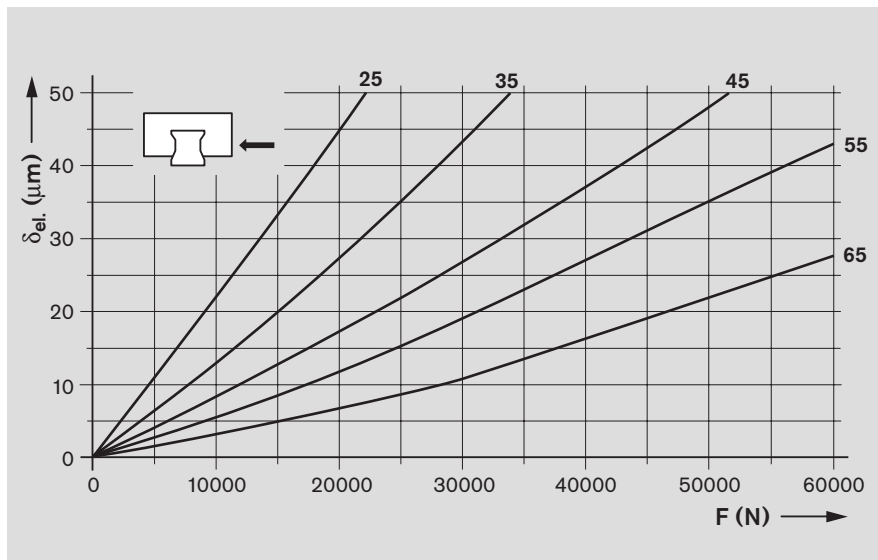
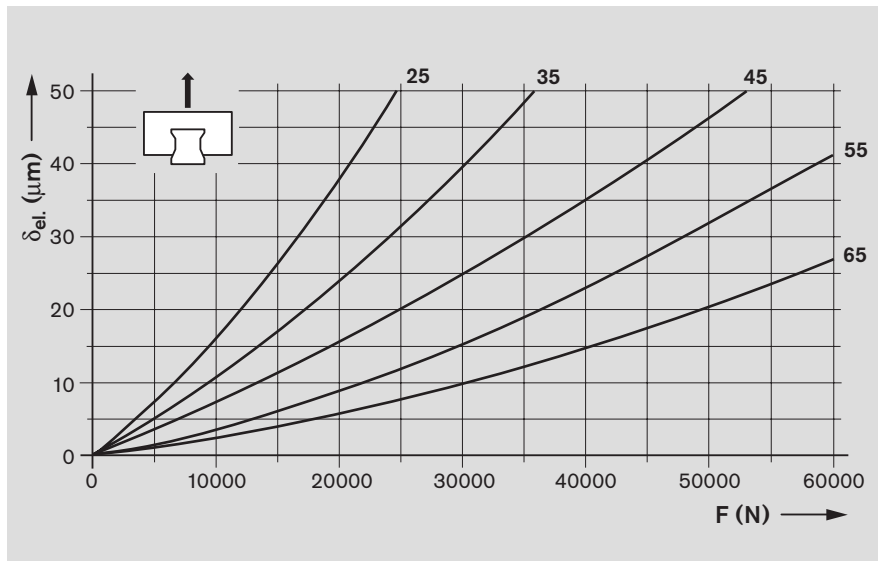
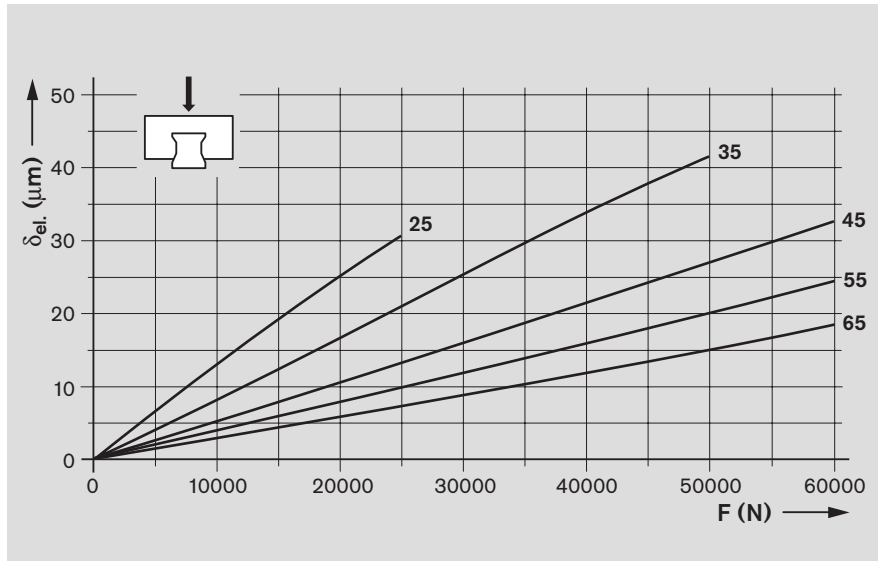

Preload class

Key to graph

$\delta_{el.}$ = elastic deflection (μm)
 F = load (N)

Rigidity of the roller rail system at preload C3

Standard runner block FNS R1851

Sizes 25 to 65

————— measured values

Runner block mounted using 6 screws:

- 4 outer screws of strength class 12.9
- 2 centerline screws of strength class 8.8

1. Down load

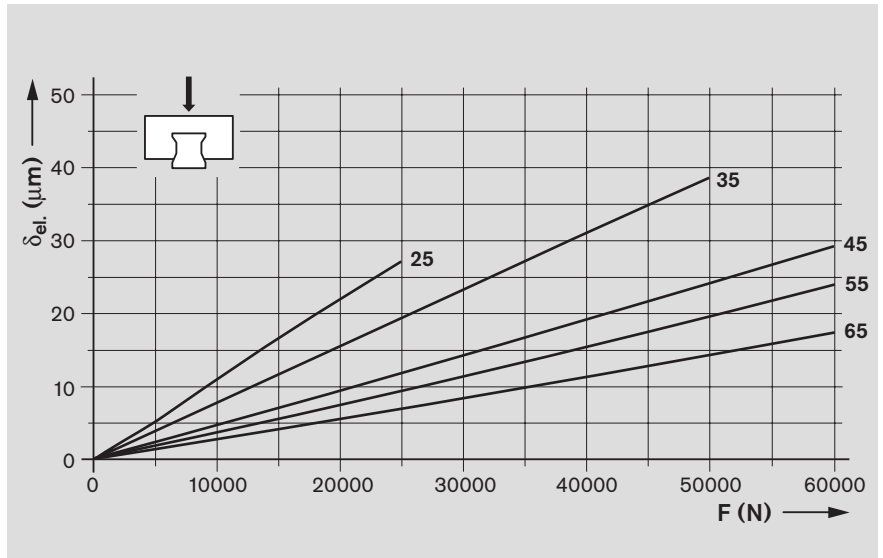

2. Lift-off load

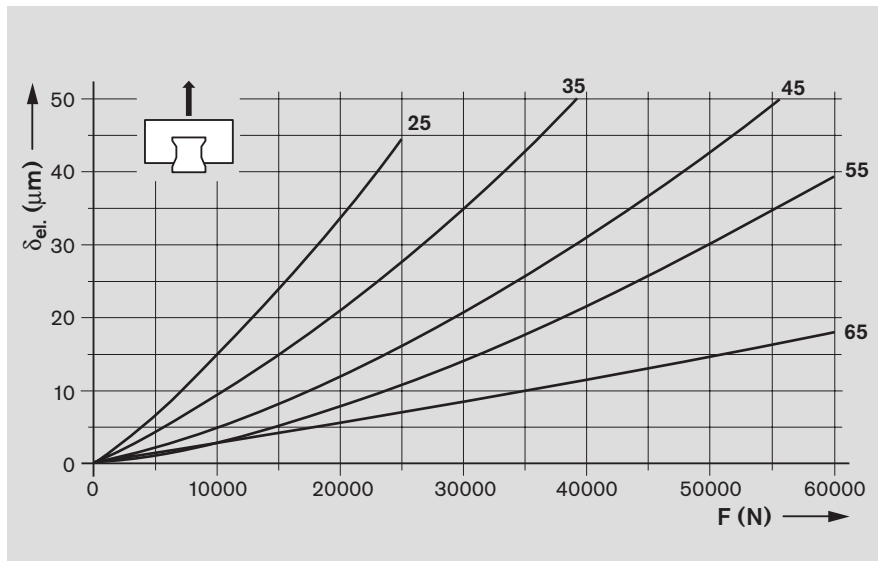

3. Side load

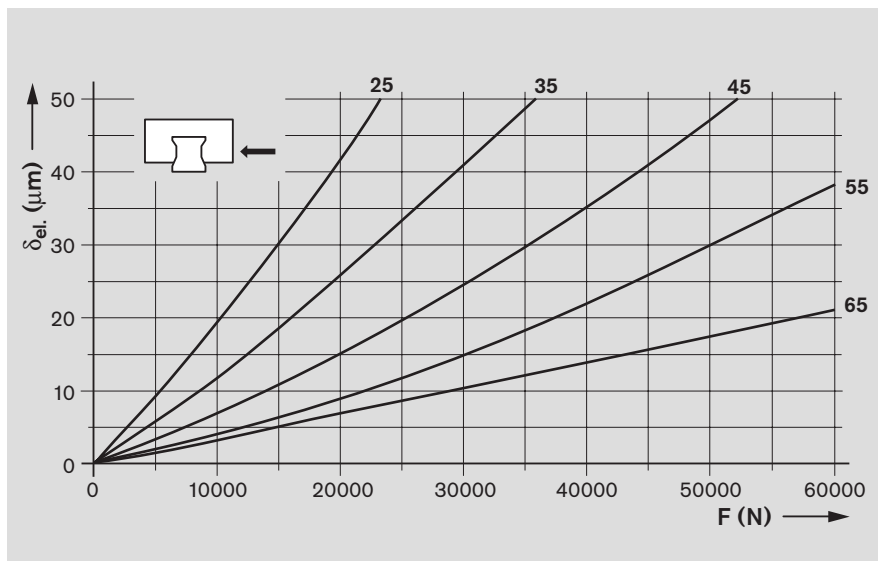

Preload class

C3 = preload 13% C

Key to graph

δ_{el.} = elastic deflection (μm)
 F = load (N)

Standard Runner Blocks, Steel version

Rigidity

Rigidity of the roller rail system at preload C2

Standard runner block FLS R1853

Sizes 25 to 65

————— measured values

Runner block mounted using

6 screws:

- 4 outer screws of strength class 12.9
- 2 centerline screws of strength class 8.8

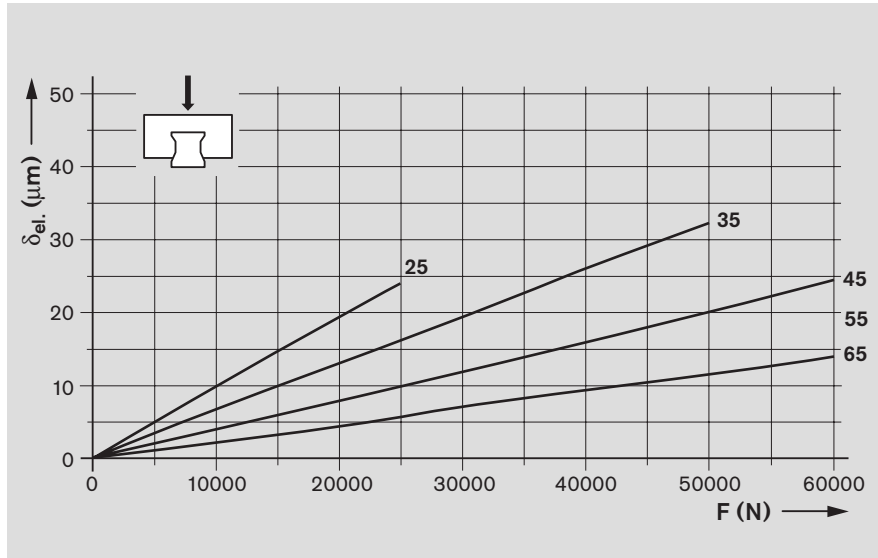

1. Down load

2. Lift-off load

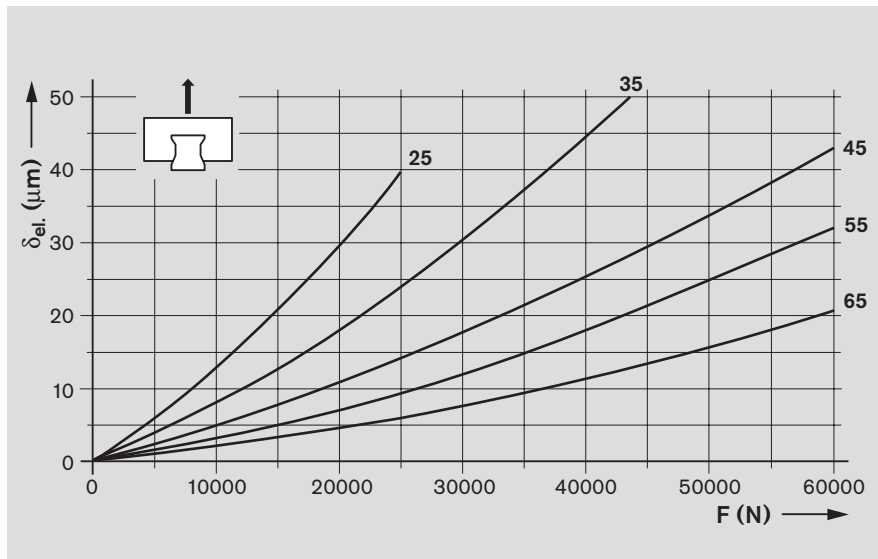

3. Side load

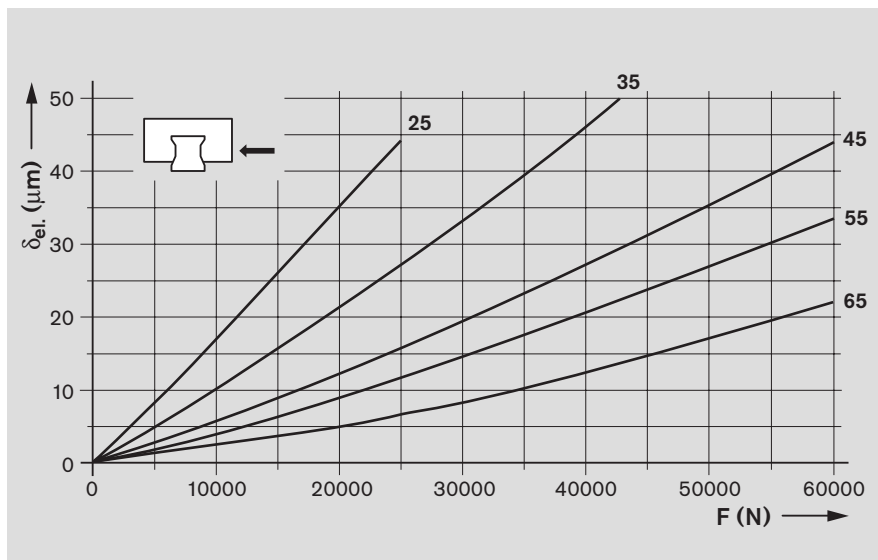

Preload class

Key to graph

$\delta_{el.}$ = elastic deflection (μm)
 F = load (N)

Rigidity of the roller rail system at preload C3

Standard runner block FLS R1853

Sizes 25 to 65

————— measured values

Runner block mounted using 6 screws:

- 4 outer screws of strength class 12.9
- 2 centerline screws of strength class 8.8

1. Down load

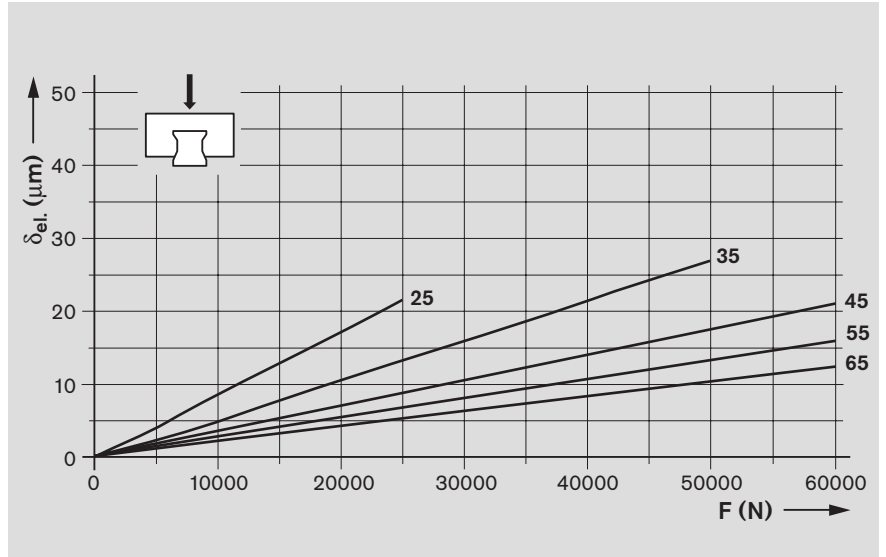

2. Lift-off load

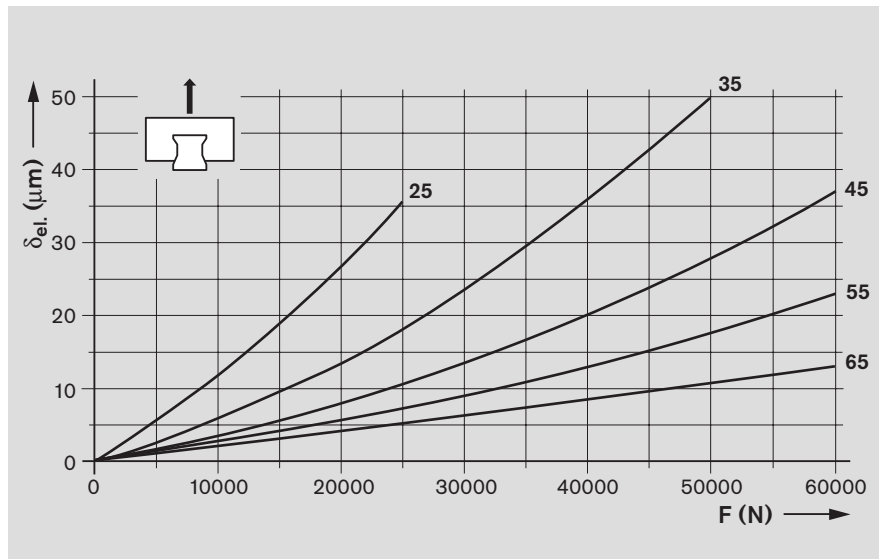

3. Side load

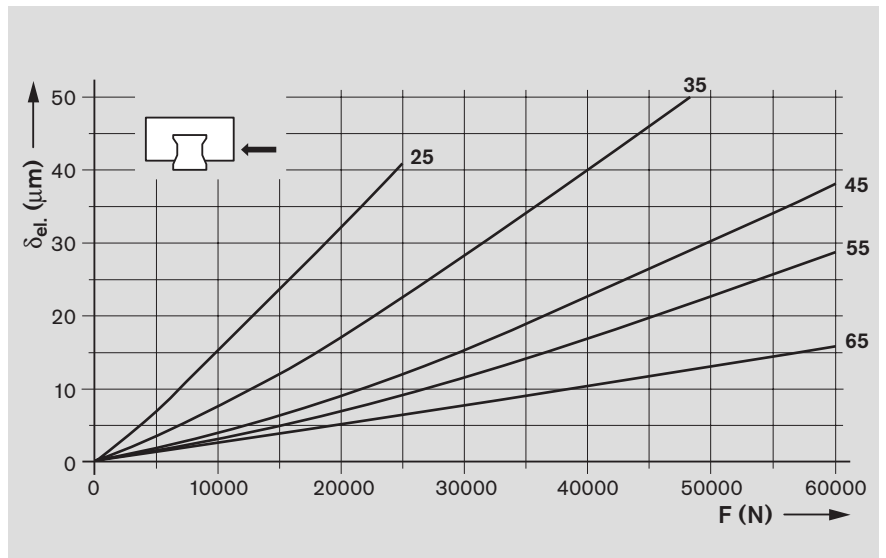

Preload class

C3 = preload 13% C

Key to graph

$\delta_{el.}$ = elastic deflection (μm)
 F = load (N)

Standard Runner Blocks, Steel version

Rigidity

Rigidity of the roller rail system at preload C2

Standard runner block SNH R1821

Sizes 25 to 55

————— measured values

Runner block mounted using
6 screws of strength class 12.9

1. Down load

2. Lift-off load

3. Side load

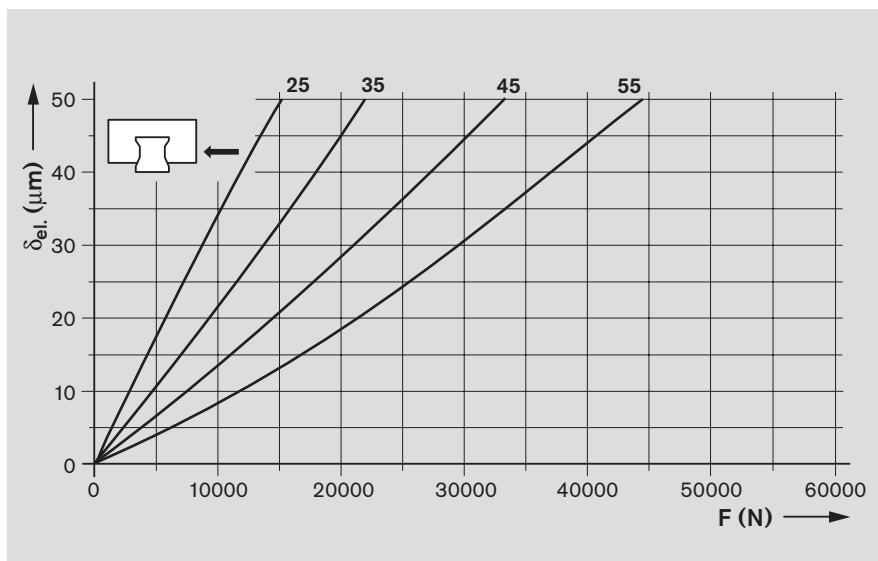
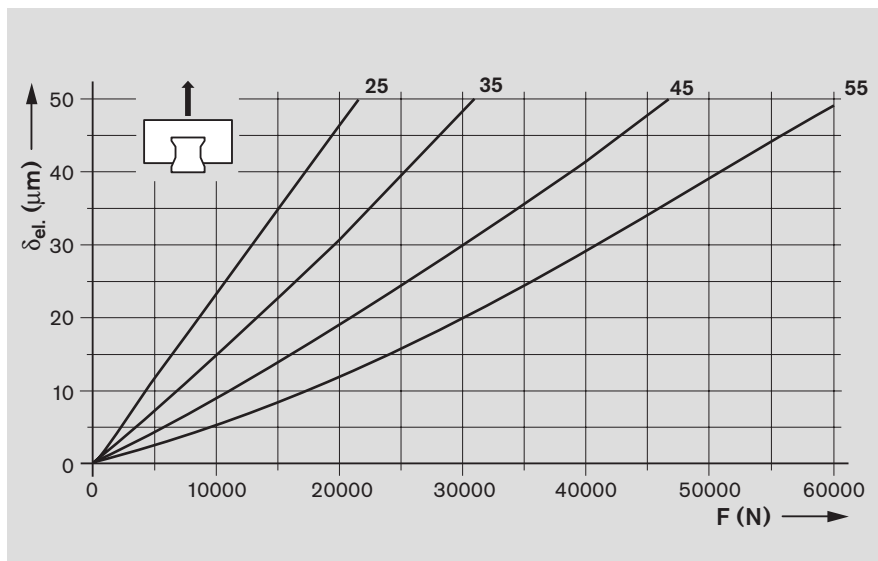
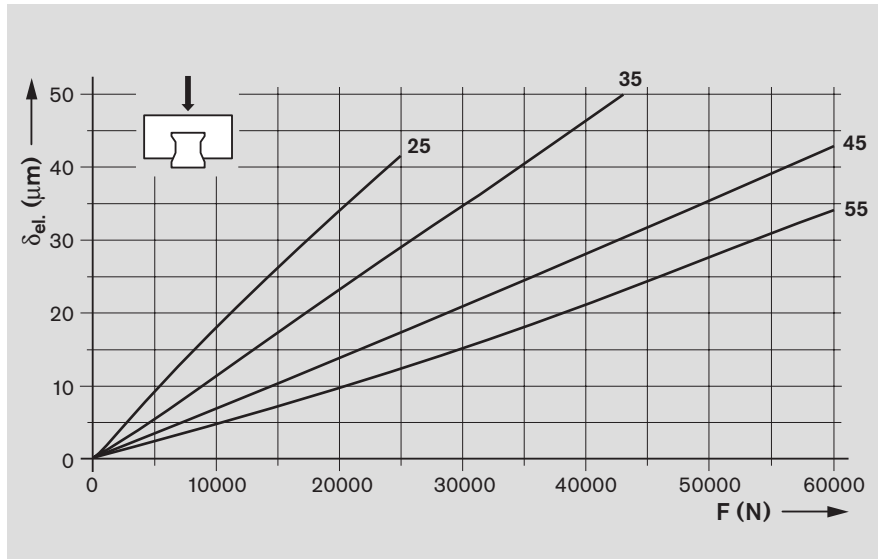

Preload class
C2 = preload 8% C

Key to graph

δ_{el.} = elastic deflection (μm)
F = load (N)

Rigidity of the roller rail system at preload C3

Standard runner block SNH R1821

Sizes 25 to 55

————— measured values

Runner block mounted using 6 screws of strength class 12.9

1. Down load

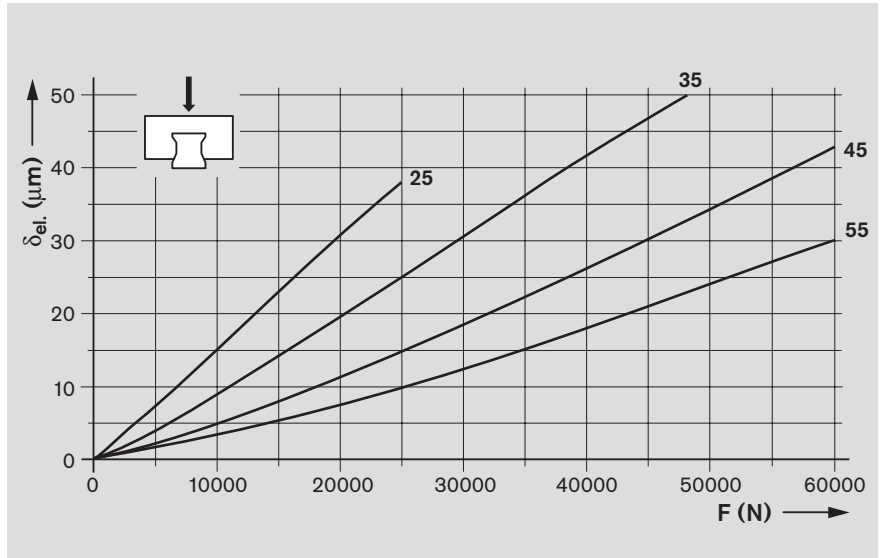

2. Lift-off load

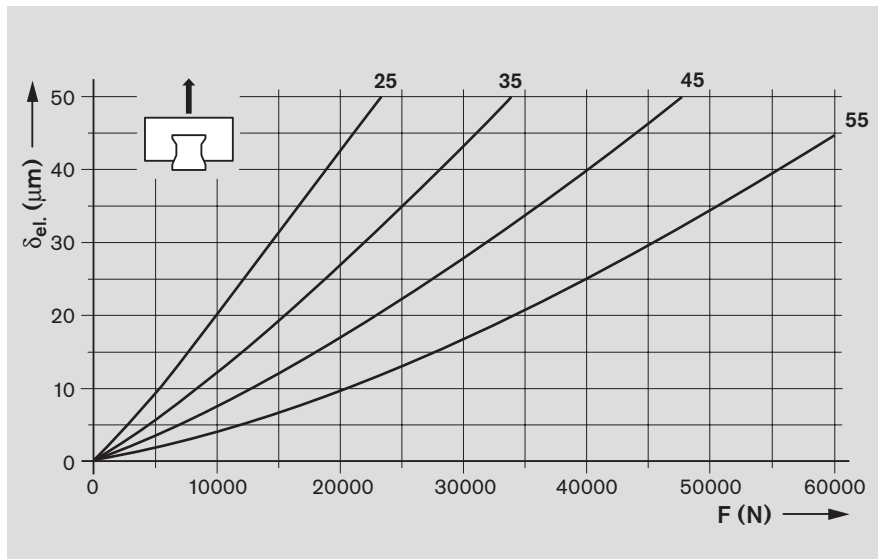

3. Side load

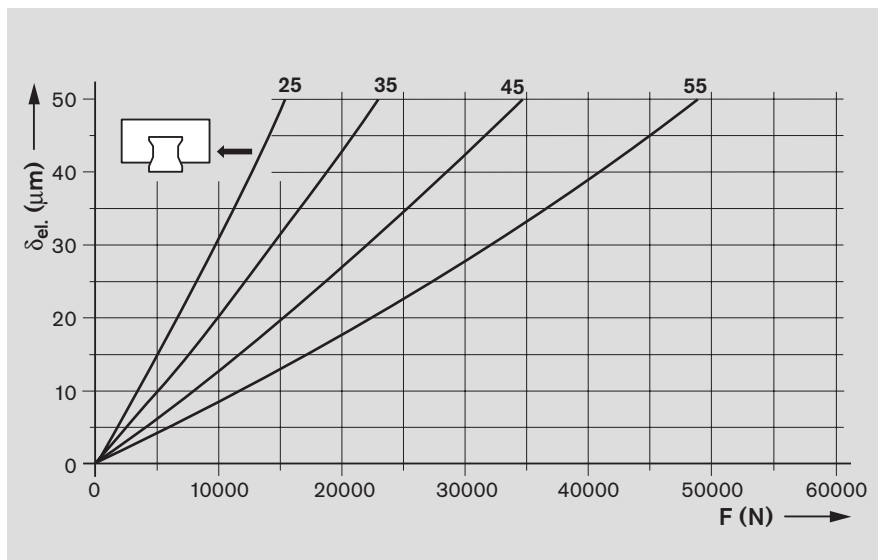

Preload class

C3 = preload 13% C

Key to graph

δ_{el.} = elastic deflection
 F = load

(μm)
 (N)

Standard Runner Blocks, Steel version

Rigidity

Rigidity of the roller rail system at preload C2

Standard runner blocks
 SLH R1824 (sizes 25 to 55) and
 SLS R1824 (size 65)

Sizes 25 to 65
 _____ measured values

Runner block mounted using
 6 screws of strength class 12.9

1. Down load

2. Lift-off load

3. Side load

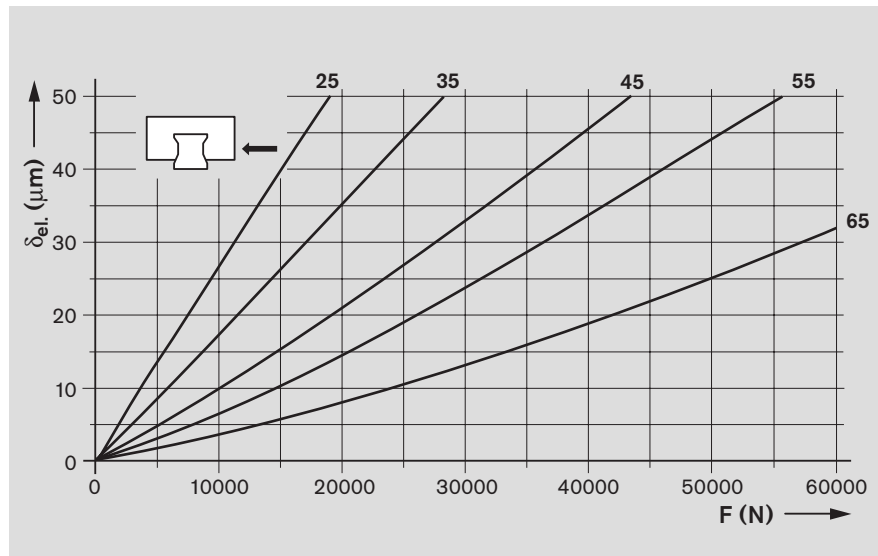
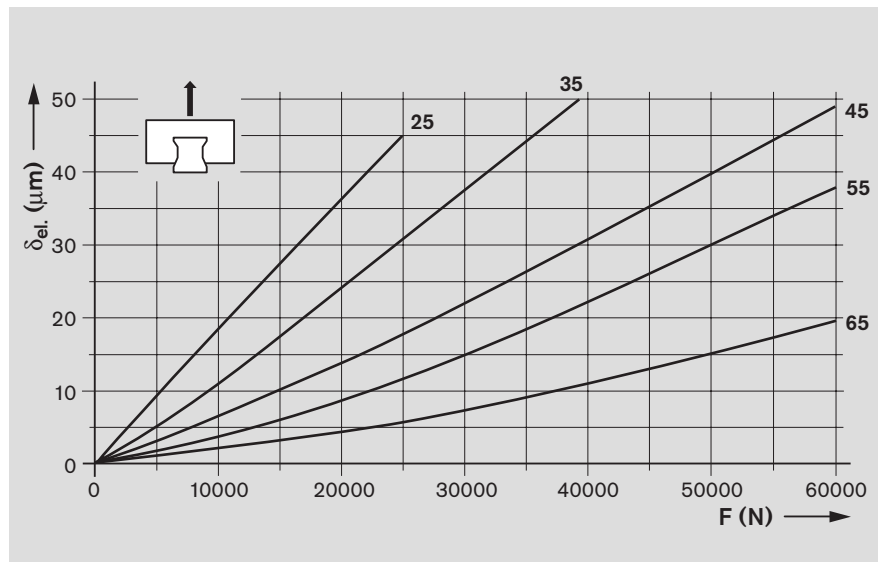
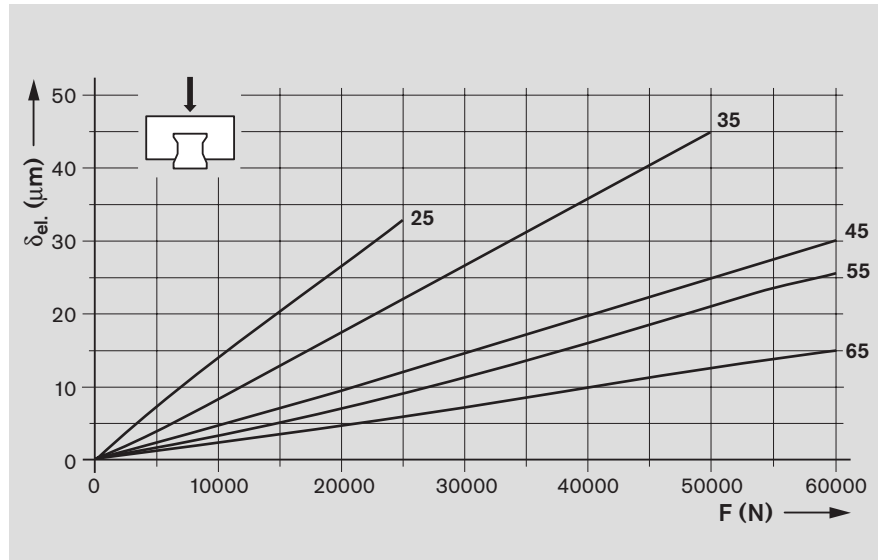

Preload class
 C2 = preload 8% C

Key to graph
 δ_{el.} = elastic deflection (μm)
 F = load (N)

Rigidity of the roller rail system at preload C3

Standard runner blocks
 SLH R1824 (sizes 25 to 55) and
 SLS R1824 (size 65)

Sizes 25 to 65
 _____ measured values

Runner block mounted using
 6 screws of strength class 12.9

1. Down load

2. Lift-off load

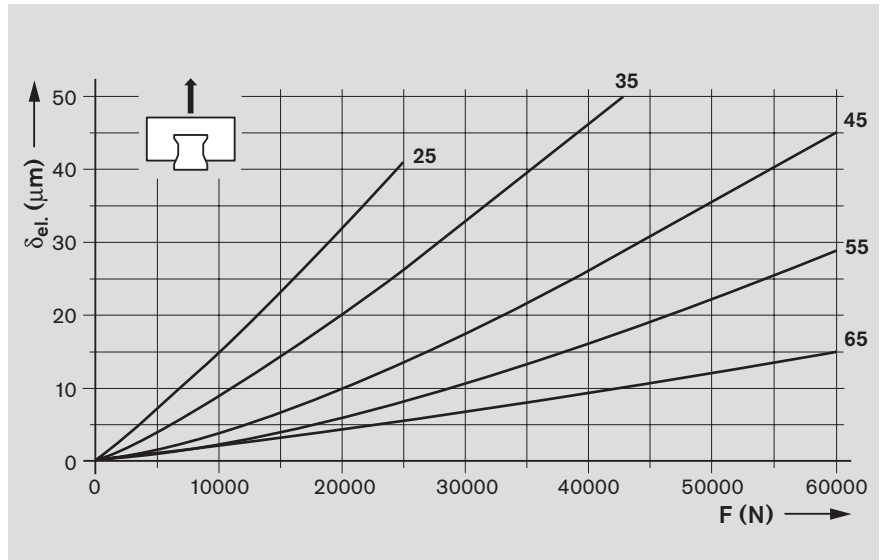
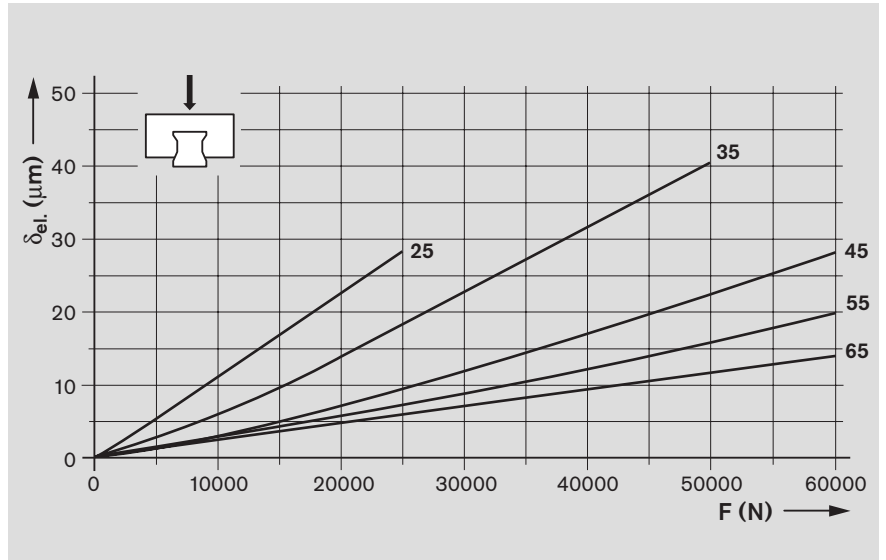

3. Side load

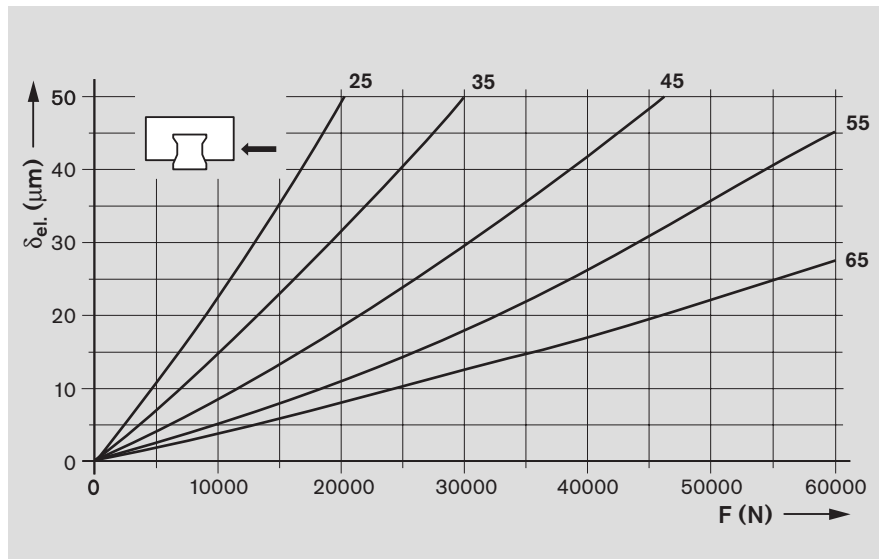

Preload class
 C3 = preload 13% C

Key to graph
 δ_{el.} = elastic deflection (μm)
 F = load (N)

Standard Runner Blocks, Steel version

Runner Block FNS

Runner block FNS R1851 ... 10 Flanged, normal, standard height

Further runner block versions

- with aluminum end caps
- for oil and grease lubrication from above
- for central oil lubrication systems
- for wall mounting

See the relevant sections for part numbers.

For corrosion-resistant runner blocks, Resist CR, matte silver hard chrome plated, see section on "Standard Runner Blocks, Resist CR".

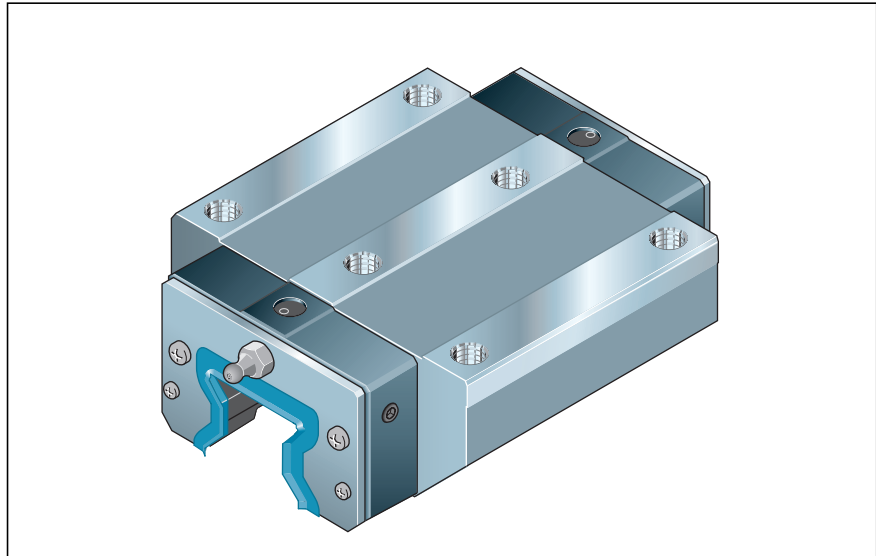

Recommended preload and accuracy class combinations

- For preload class C2: H and P
 - For preload class C3: P and SP
- Preference should be given to runner blocks with preload C2. Runner blocks with preload C1 are available on request. Part number: R1851 .1. 10

Preload classes

C1 = preload 3% C
(on request)

C2 = preload 8% C





C3 = preload 13% C

Size	Accuracy class	Part numbers for preload class	
		C2	C3
25	H	R1851 223 10	–
	P	R1851 222 10	R1851 232 10
	SP	R1851 221 10	R1851 231 10
	UP	R1851 229 10	R1851 239 10
35	H	R1851 323 10	–
	P	R1851 322 10	R1851 332 10
	SP	R1851 321 10	R1851 331 10
	UP	R1851 329 10	R1851 339 10
45	H	R1851 423 10	–
	P	R1851 422 10	R1851 432 10
	SP	R1851 421 10	R1851 431 10
	UP	R1851 429 10	R1851 439 10
55	H	R1851 523 10	–
	P	R1851 522 10	R1851 532 10
	SP	R1851 521 10	R1851 531 10
	UP	R1851 529 10	R1851 539 10
65	H	R1851 623 10	–
	P	R1851 622 10	R1851 632 10
	SP	R1851 621 10	R1851 631 10
	UP	R1851 629 10	R1851 639 10

Note on dynamic load capacities and moments (see table)

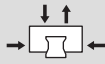
The dynamic load capacities and moments are based on 100,000 m travel. However, a travel of just 50,000 m is often taken as a basis.

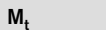
If this is the case, for comparison purposes: Multiply values **C**, **M_t** and **M_L** from the table by 1.23.

Size	Load capacities (N)		Moment loads (Nm)			
						
25	26 900	53 200	348	690	260	520
35	56 300	113 500	1 114	2 245	700	1 400
45	92 300	184 800	2 277	4 559	1 430	2 860
55	128 900	248 600	3 779	7 288	2 400	4 620
65	207 000	382 000	7 300	13 500	4 590	8 470

Standard runner block FNS R1851 ... 10

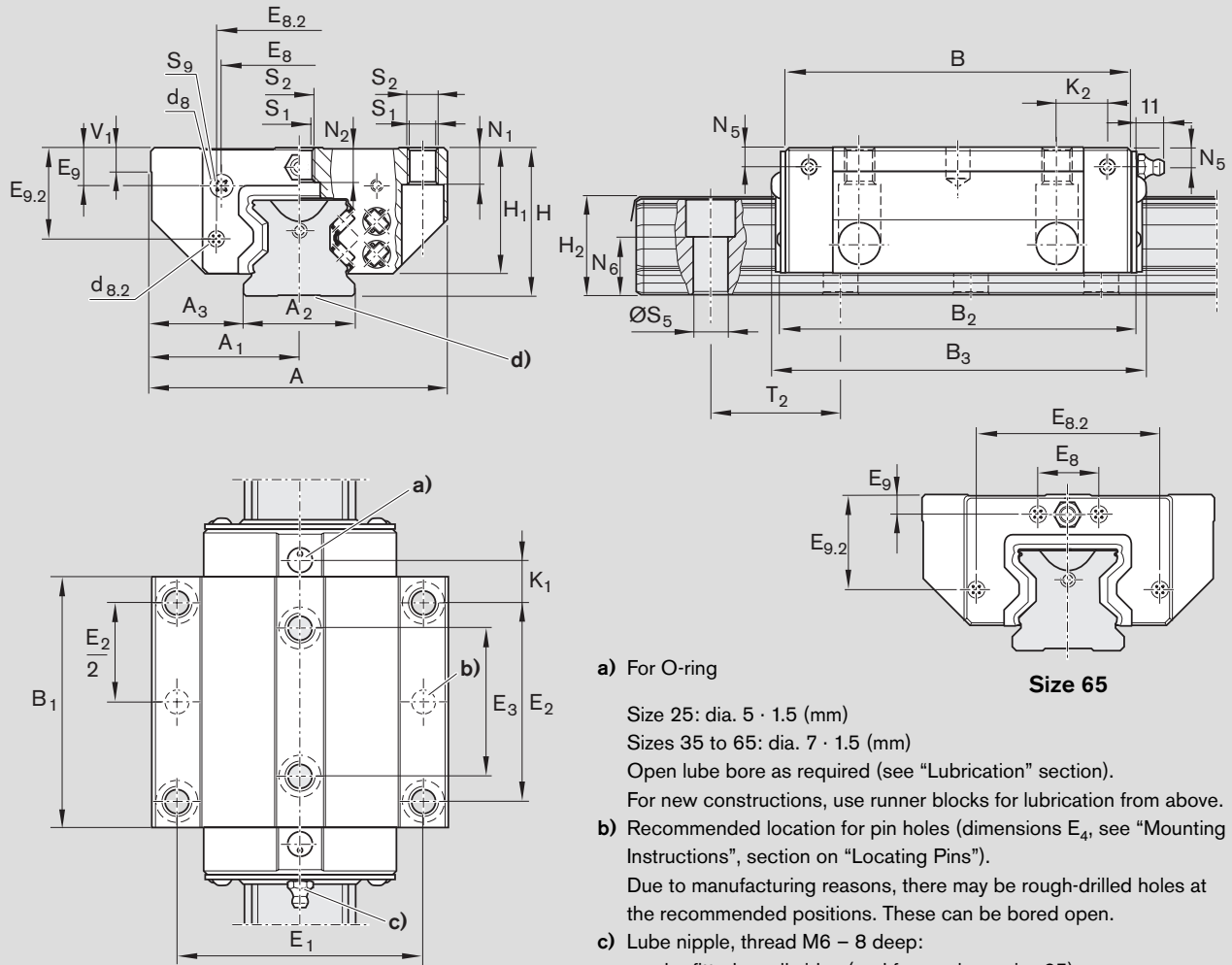

- a) For O-ring
 Size 25: dia. 5 · 1.5 (mm)
 Sizes 35 to 65: dia. 7 · 1.5 (mm)
 Open lube bore as required (see "Lubrication" section).
 For new constructions, use runner blocks for lubrication from above.
- b) Recommended location for pin holes (dimensions E₄, see "Mounting Instructions", section on "Locating Pins").
 Due to manufacturing reasons, there may be rough-drilled holes at the recommended positions. These can be bored open.
- c) Lube nipple, thread M6 – 8 deep:
 can be fitted on all sides (end face only on size 25).
 Other lube fittings will have different dimensions.
 For more details on lube fittings, see the "Accessories" section.
- d) Due to manufacturing reasons, guide rails in accuracy class H may not have a slot on the base.

Size	Dimensions (mm)																
	A	A ₁	A ₂	A ₃	B	B ₁	B ₂	B ₃	d ₈	d _{8.2}	E ₁	E ₂	E ₃	E ₈	E _{8.2}	E ₉	E _{9.2}
25	70	35	23	23.5	91.0	63.5	93.0	97	6	5	57	45	40	33.4	40.22	8.40	21.40
35	100	50	34	33.0	114.0	79.6	116.0	121	6	5	82	62	52	50.3	56.60	13.10	29.10
45	120	60	45	37.5	140.0	101.5	144.0	150	8	6	100	80	60	62.9	69.55	16.70	36.50
55	140	70	53	43.5	166.5	123.1	170.5	177	10	6	116	95	70	74.2	81.60	18.85	40.75
65	170	85	63	53.5	206.0	146.0	216.5	218	8	8	142	110	82	35.0	106.00	9.30	55.00

Size	Dimensions (mm)																Weight kg
	H	H ₁	H ₂ ¹⁾	H ₂ ²⁾	K ₁	K ₂	N ₁	N ₂	N ₅	N ₆ ^{±0.5}	S ₁	S ₂	S ₅	S ₉ ³⁾	T ₂ ⁴⁾	V ₁	
25	36	30	23.60	23.40	14.10	-	9	7.3	5.5	14.3	6.8	M8	7	M3-5deep	30.0	7.5	0.8
35	48	41	31.10	30.80	15.55	17.40	12	11.0	7.0	19.4	8.6	M10	9	M3-5deep	40.0	8.0	1.7
45	60	51	39.10	38.80	17.45	20.35	15	13.5	8.0	22.4	10.5	M12	14	M4-7deep	52.5	10.0	3.3
55	70	58	47.85	47.55	21.75	24.90	18	13.7	9.0	28.7	12.5	M14	16	M5-8deep	60.0	12.0	5.5
65	90	76	58.15	57.85	29.80	33.00	23	21.5	9.3	36.5	14.5	M16	18	M4-7deep	75.0	15.0	12.0

1) Dimension H₂ with cover strip
 2) Dimension H₂ without cover strip
 3) Thread for attachments
 4) Dimension T₂ = hole spacing in the guide rail

Standard Runner Blocks, Steel version

Runner Block FLS

Runner block FLS R1853 ... 10 Flanged, long, standard height

Further runner block versions

- with aluminum end caps
- for oil and grease lubrication from above
- for central oil lubrication systems
- for wall mounting

See the relevant sections for part numbers.

For corrosion-resistant runner blocks, Resist CR, matte silver hard chrome plated, see section on "Standard Runner Blocks, Resist CR".

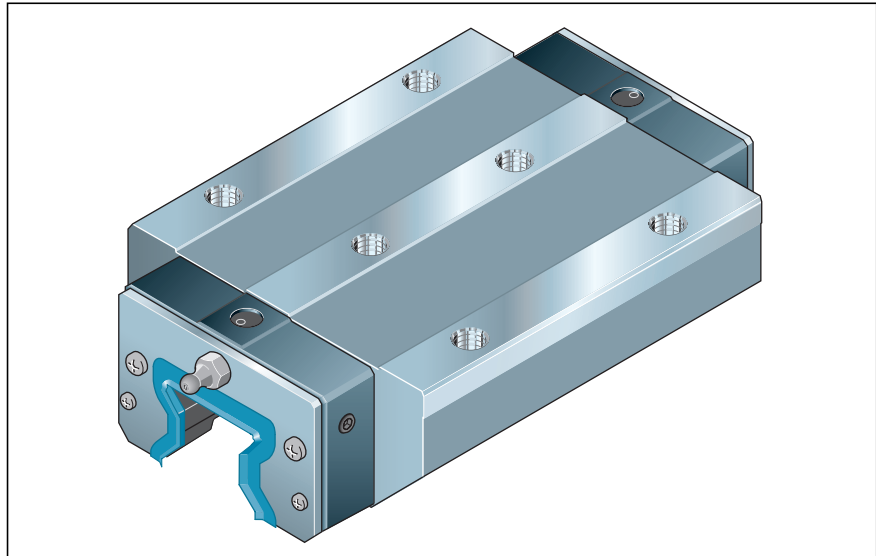

Recommended preload and accuracy class combinations

- For preload class C2: H and P
 - For preload class C3: P and SP
- Preference should be given to runner blocks with preload C2.
Runner blocks with preload C1 are available on request. Part number: R1853 .1. 10

Preload classes

- C1 = preload 3% C (on request)
- C2 = preload 8% C
- C3 = preload 13% C

Size	Accuracy class	Part numbers for preload class	
		C2	C3
25	H	R1853 223 10	-
	P	R1853 222 10	R1853 232 10
	SP	R1853 221 10	R1853 231 10
	UP	R1853 229 10	R1853 239 10
35	H	R1853 323 10	-
	P	R1853 322 10	R1853 332 10
	SP	R1853 321 10	R1853 331 10
	UP	R1853 329 10	R1853 339 10
45	H	R1853 423 10	-
	P	R1853 422 10	R1853 432 10
	SP	R1853 421 10	R1853 431 10
	UP	R1853 429 10	R1853 439 10
55	H	R1853 523 10	-
	P	R1853 522 10	R1853 532 10
	SP	R1853 521 10	R1853 531 10
	UP	R1853 529 10	R1853 539 10
65	H	R1853 623 10	-
	P	R1853 622 10	R1853 632 10
	SP	R1853 621 10	R1853 631 10
	UP	R1853 629 10	R1853 639 10

Note on dynamic load capacities and moments (see table)

The dynamic load capacities and moments are based on 100,000 m travel. However, a travel of just 50,000 m is often taken as a basis.

If this is the case, for comparison purposes: Multiply values **C**, **M_t** and **M_L** from the table by 1.23.

Size	Load capacities (N)		Moment loads (Nm)			
	C	C ₀	M _t	M ₁₀	M _L	M _{L0}
25	33 300	70 000	432	908	420	900
35	69 700	149 300	1 375	2 953	1 135	2 430
45	119 200	256 600	2 941	6 331	2 520	5 430
55	165 000	345 300	4 837	10 122	4 030	8 440
65	265 500	525 600	9 410	18 630	7 960	15 760

Standard runner block FLS R1853 ... 10

Size 65

- a) For O-ring
 Size 25: dia. 5 · 1.5 (mm)
 Sizes 35 to 65: dia. 7 · 1.5 (mm)
 Open lube bore as required (see "Lubrication" section).
 For new constructions, use runner blocks for lubrication from above.
- b) Recommended location for pin holes
 (see "Mounting Instructions", section on "Locating Pins").
 Due to manufacturing reasons, there may be rough-drilled holes at the recommended positions. These can be bored open.
- c) Lube nipple, thread M6 – 8 deep:
 can be fitted on all sides (end face only on size 25).
 Other lube fittings will have different dimensions.
 For more details on lube fittings, see the "Accessories" section.
- d) Due to manufacturing reasons, guide rails in accuracy class H may not have a slot on the base.

Size	Dimensions (mm)																
	A	A ₁	A ₂	A ₃	B	B ₁	B ₂	B ₃	d ₈	d _{8.2}	E ₁	E ₂	E ₃	E ₈	E _{8.2}	E ₉	E _{9.2}
25	70	35	23	23.5	109.0	81.5	111.0	115	6	5	57	45	40	33.4	40.22	8.40	21.40
35	100	50	34	33.0	138.0	103.6	140.0	145	6	5	82	62	52	50.3	56.60	13.10	29.10
45	120	60	45	37.5	172.5	134.0	176.5	183	8	6	100	80	60	62.9	69.55	16.70	36.50
55	140	70	53	43.5	205.5	162.1	209.5	216	10	6	116	95	70	74.2	81.60	18.85	40.75
65	170	85	63	53.5	254.0	194.0	258.5	264	8	8	142	110	82	35.0	106.00	9.30	55.00

Size	Dimensions (mm)																Weight kg
	H	H ₁	H ₂ ¹⁾	H ₂ ²⁾	K ₁	K ₂	N ₁	N ₂	N ₅	N ₆ ^{±0.5}	S ₁	S ₂	S ₅	S ₉ ³⁾	T ₂ ⁴⁾	V ₁	
25	36	30	23.60	23.40	23.10	–	9	7.3	5.5	14.3	6.8	M8	7	M3-5deep	30.0	7.5	1.1
35	48	41	31.10	30.80	27.55	29.4	12	11.0	7.0	19.4	8.6	M10	9	M3-5deep	40.0	8.0	2.5
45	60	51	39.10	38.80	33.70	36.6	15	13.5	8.0	22.4	10.5	M12	14	M4-7deep	52.5	10.0	4.7
55	70	58	47.85	47.55	41.25	44.4	18	13.7	9.0	28.7	12.5	M14	16	M5-8deep	60.0	12.0	7.7
65	90	76	58.15	57.85	53.80	57.0	23	21.5	9.3	36.5	14.5	M16	18	M4-7deep	75.0	15.0	14.5

1) Dimension H₂ with cover strip
 2) Dimension H₂ without cover strip

3) Thread for attachments
 4) Dimension T₂ = hole spacing in the guide rail

Standard Runner Blocks, Steel version

Runner Block SNH

Runner block SNH R1821 ... 10 Slimline, normal, high

Further runner block versions

- with aluminum end caps
- for oil and grease lubrication from above
- for central oil lubrication systems
- for wall mounting

See the relevant sections for part numbers.

For corrosion-resistant runner blocks, Resist CR, matte silver hard chrome plated, see section on "Standard Runner Blocks, Resist CR."

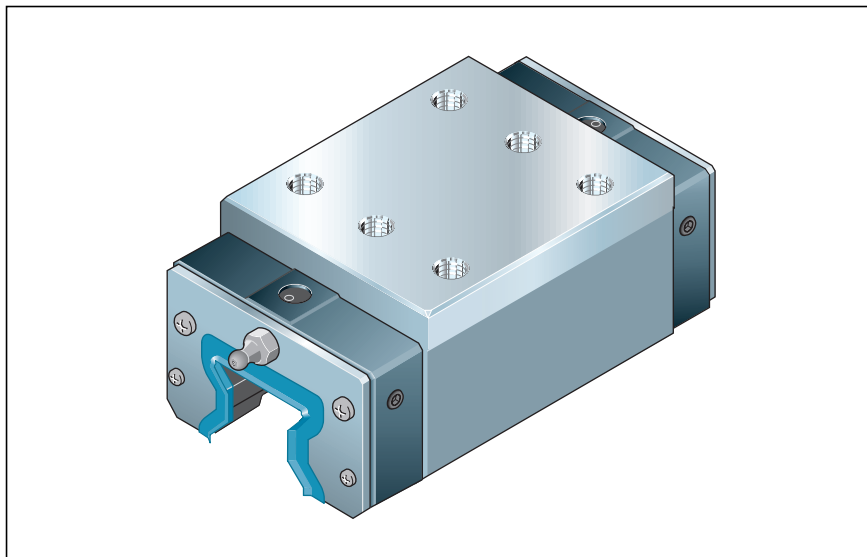

Recommended preload and accuracy class combinations

- For preload class C2: H and P
- For preload class C3: P and SP

Preference should be given to runner blocks with preload C2.

Runner blocks with preload C1 are available on request. Part number: R1821 .1. 10

Preload classes

C1 = preload 3% C
(on request)





C2 = preload 8% C

Size	Accuracy class	Part numbers for preload class	
		C2	C3
25	H	R1821 223 10	–
	P	R1821 222 10	R1821 232 10
	SP	R1821 221 10	R1821 231 10
	UP	R1821 229 10	R1821 239 10
35	H	R1821 323 10	–
	P	R1821 322 10	R1821 332 10
	SP	R1821 321 10	R1821 331 10
	UP	R1821 329 10	R1821 339 10
45	H	R1821 423 10	–
	P	R1821 422 10	R1821 432 10
	SP	R1821 421 10	R1821 431 10
	UP	R1821 429 10	R1821 439 10
55	H	R1821 523 10	–
	P	R1821 522 10	R1821 532 10
	SP	R1821 521 10	R1821 531 10
	UP	R1821 529 10	R1821 539 10

Note on dynamic load capacities and moments (see table)

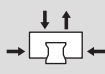
The dynamic load capacities and moments are based on 100,000 m travel. However, a travel of just 50,000 m is often taken as a basis.

If this is the case, for comparison purposes: Multiply values **C**, **M_t** and **M_L** from the table by 1.23.

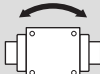
Size	Load capacities (N)		Moment loads (Nm)			
	 C	 C ₀	 M _t	 M _{t0}	 M _L	 M _{L0}
25	26 900	53 200	348	690	260	520
35	56 300	113 500	1 114	2 245	700	1 400
45	92 300	184 800	2 277	4 559	1 430	2 860
55	128 900	248 600	3 779	7 288	2 400	4 620

Standard runner block SNH R1821 ... 10

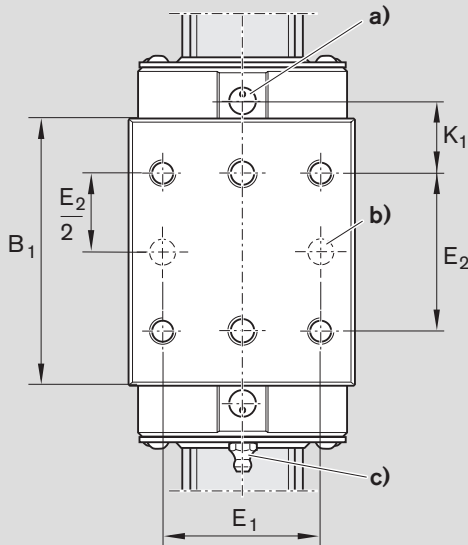
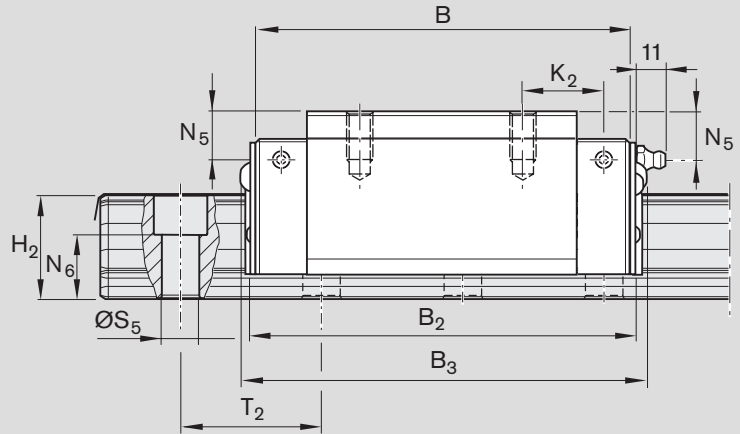
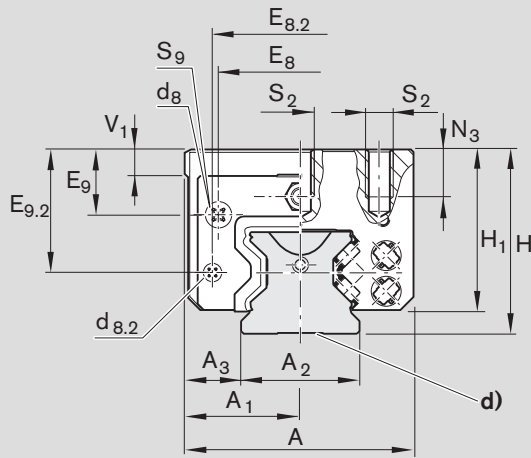

- a) For O-ring
 Size 25: dia. 5 · 1.5 (mm)
 Sizes 35 to 55: dia. 7 · 1.5 (mm)
 Open lube bore as required. Send for instructions.
 For new constructions, use runner blocks for lubrication from above.
- b) Recommended location for pin holes
 (see "Mounting Instructions", section on "Locating Pins").
 Due to manufacturing reasons, there may be rough-drilled holes at the recommended positions. These can be bored open.
- c) Lube nipple, thread M6 – 8 deep:
 can be fitted on all sides (end face only on size 25).
 Other lube fittings will have different dimensions.
 For more details on lube fittings, see the "Accessories" section.
- d) Due to manufacturing reasons, guide rails in accuracy class H may not have a slot on the base.

Size	Dimensions (mm)															
	A	A ₁	A ₂	A ₃	B	B ₁	B ₂	B ₃	d ₈	d _{8.2}	E ₁	E ₂	E ₈	E _{8.2}	E ₉	E _{9.2}
25	48	24	23	12.5	91.0	63.5	93.0	97	6	5	35	35	33.4	40.22	12.40	25.40
35	70	35	34	18.0	114.0	79.6	116.0	121	6	5	50	50	50.3	56.60	20.10	36.10
45	86	43	45	20.5	140.0	101.5	144.0	150	8	6	60	60	62.9	69.55	26.75	46.50
55	100	50	53	23.5	166.5	123.1	170.5	177	10	6	75	75	74.2	81.60	28.95	50.75

Size	Dimensions (mm)															Weight kg
	H	H ₁	H ₂ ¹⁾	H ₂ ²⁾	K ₁	K ₂	N ₃	N ₅	N ₆ ^{±0.5}	S ₂	S ₅	S ₉ ³⁾	T ₂ ⁴⁾	V ₁		
25	40	34	23.60	23.40	19.10	-	9	9.5	14.3	M6	7	M3-5deep	30.0	7.5	0.6	
35	55	48	31.10	30.80	21.55	23.40	13	14.0	19.4	M8	9	M3-5deep	40.0	8.0	1.5	
45	70	61	39.10	38.80	27.45	30.35	18	18.0	22.4	M10	14	M4-7deep	52.5	10.0	3.1	
55	80	68	47.85	47.55	31.75	34.95	19	19.0	28.7	M12	16	M5-8deep	60.0	12.0	4.6	

- 1) Dimension H₂ with cover strip
- 2) Dimension H₂ without cover strip
- 3) Thread for attachments
- 4) Dimension T₂ = hole spacing in the guide rail

Standard Runner Blocks, Steel version

Runner Block SLH

Runner block SLH
R1824 ... 10
Slimline, long, high
(Sizes 25 to 55)

Size 65:
Runner block SLS
1824 ... 10
Slimline, long, standard height

Further runner block versions

- with aluminum end caps
- for oil and grease lubrication from above
- for central oil lubrication systems
- for wall mounting

See the relevant sections for part numbers.

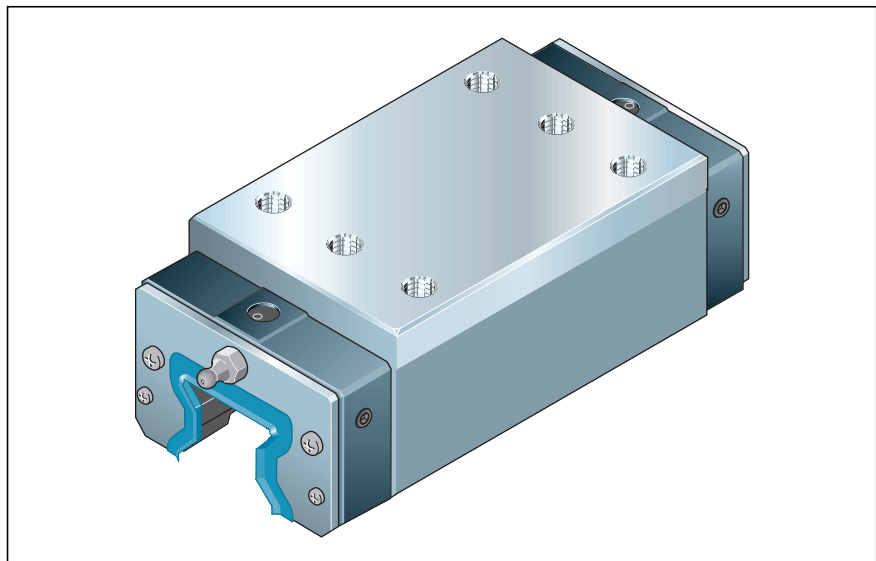

For corrosion-resistant runner blocks, Resist CR, matte silver hard chrome plated, see section on "Standard Runner Blocks, Resist CR".

Recommended preload and accuracy class combinations

- For preload class C2: H and P
 - For preload class C3: P and SP
- Preference should be given to runner blocks with preload C2.
 Runner blocks with preload C1 are available on request. Part number: R1824 .1. 10

Preload classes

C1 = preload 3% C
 (on request)

C2 = preload 8% C







C3 = preload 13% C

Size	Accuracy class	Part numbers for preload class	
		C2	C3
25	H	R1824 223 10	–
	P	R1824 222 10	R1824 232 10
	SP	R1824 221 10	R1824 231 10
	UP	R1824 229 10	R1824 239 10
35	H	R1824 323 10	–
	P	R1824 322 10	R1824 332 10
	SP	R1824 321 10	R1824 331 10
	UP	R1824 329 10	R1824 339 10
45	H	R1824 423 10	–
	P	R1824 422 10	R1824 432 10
	SP	R1824 421 10	R1824 431 10
	UP	R1824 429 10	R1824 439 10
55	H	R1824 523 10	–
	P	R1824 522 10	R1824 532 10
	SP	R1824 521 10	R1824 531 10
	UP	R1824 529 10	R1824 539 10
65	H	R1824 623 10	–
	P	R1824 622 10	R1824 632 10
	SP	R1824 621 10	R1824 631 10
	UP	R1824 629 10	R1824 639 10

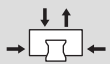
Note on dynamic load capacities and moments (see table)

The dynamic load capacities and moments are based on 100,000 m travel. However, a travel of just 50,000 m is often taken as a basis.

If this is the case, for comparison purposes: Multiply values **C**, **M_t** and **M_L** from the table by 1.23.

Size	Load capacities (N)		Moment loads (Nm)			
	 C	 C ₀	 M _t	 M ₁₀	 M _L	 M _{L0}
25	33 300	70 000	432	908	420	900
35	69 700	149 300	1 375	2 953	1 135	2 430
45	119 200	256 600	2 941	6 331	2 520	5 430
55	165 000	345 300	4 837	10 122	4 030	8 440
65	265 500	525 600	9 410	18 630	7 960	15 760

Standard runner block SLH R1824 ... 10

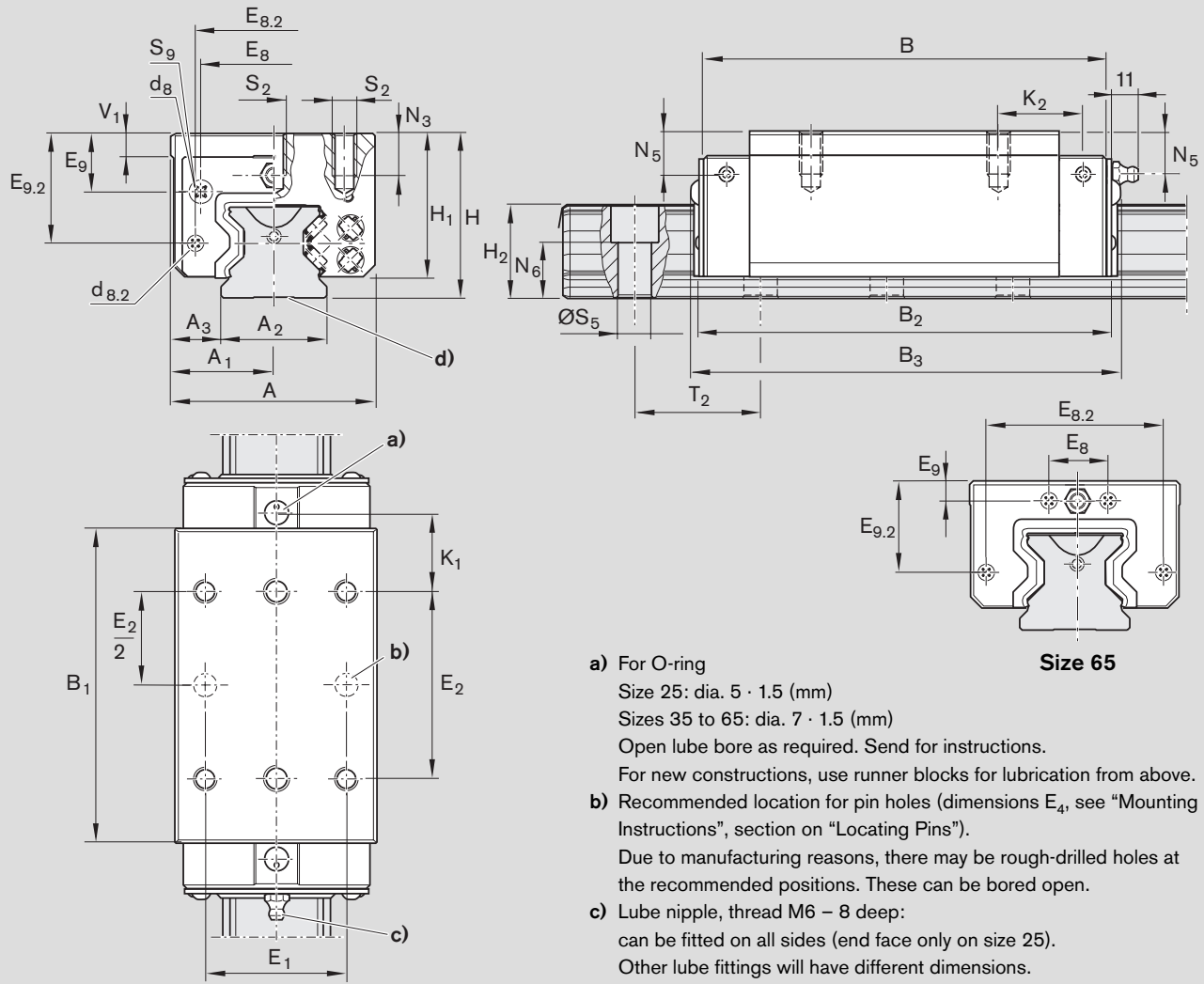

- a) For O-ring
 Size 25: dia. 5 · 1.5 (mm)
 Sizes 35 to 65: dia. 7 · 1.5 (mm)
 Open lube bore as required. Send for instructions.
 For new constructions, use runner blocks for lubrication from above.
- b) Recommended location for pin holes (dimensions E₄, see "Mounting Instructions", section on "Locating Pins").
 Due to manufacturing reasons, there may be rough-drilled holes at the recommended positions. These can be bored open.
- c) Lube nipple, thread M6 – 8 deep:
 can be fitted on all sides (end face only on size 25).
 Other lube fittings will have different dimensions.
 For more details on lube fittings, see the "Accessories" section.
- d) Due to manufacturing reasons, guide rails in accuracy class H may not have a slot on the base.

Size	Dimensions (mm)															
	A	A ₁	A ₂	A ₃	B	B ₁	B ₂	B ₃	d ₈	d _{8.2}	E ₁	E ₂	E ₈	E _{8.2}	E ₉	E _{9.2}
25	48	24	23	12.5	109.0	81.5	111.0	115	6	5	35	50	33.4	40.22	12.40	25.40
35	70	35	34	18.0	138.0	103.6	140.0	145	6	5	50	72	50.3	56.60	20.10	36.10
45	86	43	45	20.5	172.5	134.0	176.5	183	8	6	60	80	62.9	69.55	26.75	46.50
55	100	50	53	23.5	205.5	162.1	209.5	216	10	6	75	95	74.2	81.60	28.95	50.75
65	126	63	63	31.5	254.0	194.0	258.5	264	8	8	76	120	35.0	106.00	9.30	55.00

Size	Dimensions (mm)															Weight kg
	H	H ₁	H ₂ ¹⁾	H ₂ ²⁾	K ₁	K ₂	N ₃	N ₅	N ₆ ^{±0.5}	S ₂	S ₅	S ₉ ³⁾	T ₂ ⁴⁾	V ₁		
25	40	34	23.60	23.40	20.60	–	9	9.5	14.3	M6	7	M3-5deep	30.0	7.5	0.9	
35	55	48	31.10	30.80	22.55	24.4	13	14.0	19.4	M8	9	M3-5deep	40.0	8.0	2.0	
45	70	61	39.10	38.80	33.70	36.6	18	18.0	22.4	M10	14	M4-7deep	52.5	10.0	4.2	
55	80	68	47.85	47.55	41.25	44.4	19	19.0	28.7	M12	16	M5-8deep	60.0	12.0	6.2	
65	90	76	58.15	57.85	48.80	52.0	21	9.3	36.5	M16	18	M4-7deep	75.0	15.0	12.0	

1) Dimension H₂ with cover strip
 2) Dimension H₂ without cover strip
 3) Thread for attachments
 4) Dimension T₂ = hole spacing in the guide rail

Standard Runner Blocks, Steel version

Runner Blocks with Aluminum End Caps

General notes on runner blocks R18.. ... 13

For part numbers, see the following page.
For dimensions, load capacities, rigidity and moment loads, please refer to the corresponding runner blocks R18.. ... 10.

Special feature:
Runner blocks R18.. ... 13 with aluminum end caps are recommended for applications with especially demanding condi-

Runner block short names

FNS = Flanged, normal, standard height
FLS = Flanged, long, standard height
SNH = Slimline, normal, high
SLH = Slimline, long, high
SLS = Slimline, long, standard height

Preload classes

C2 = preload 8% C

Aluminum end cap

Aluminum end caps with integrated seal and end seal can also be ordered separately (see "Spare Parts").

Lube fitting at the side

For lube fittings at the side, the maximum depth for size 45 is 6 mm. When using the standard lube nipple, a 2 mm washer is required.

Lube fitting at the top

For lubrication from above, remove screw plug and insert an O-ring seal:

- Sizes 35 and 55: dia. 7 · 1.5 (mm)
- Sizes 45 and 65: dia. 10 · 1.5 (mm)

For the high runner blocks S.H R182.. ... 13 and lubrication from above, use lube adapter (not included in supply scope; please consult us).

High runner blocks S.H R182.. ... 13 for lubrication from above with integrated (plastic) lube adapter are available on request.

Runner Blocks, Resist CR (optional)

For corrosion-resistant runner blocks, Resist CR, matte silver hard chrome plated, see section on "Standard Runner Blocks, Resist CR".

Standard Runner Blocks, Steel version

Runner Blocks with Aluminum End Caps

Runner block FNS R1851 ... 13

Size	Accuracy class	Part numbers for preload class	
		C2	C3
25 ¹⁾	P	–	–
	SP	–	–
35	P	R1851 322 13	R1851 332 13
	SP	–	R1851 331 13
45	P	R1851 422 13	R1851 432 13
	SP	–	R1851 431 13
55	P	R1851 522 13	R1851 532 13
	SP	–	R1851 531 13
65	P	R1851 622 13	R1851 632 13
	SP	–	R1851 631 13

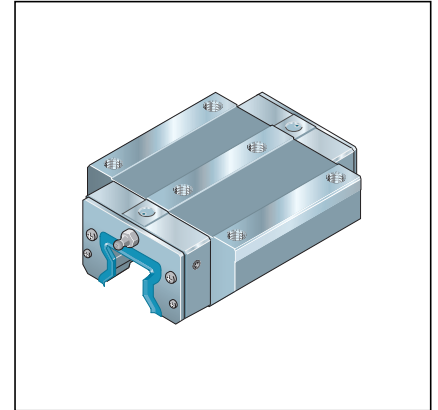

Runner block FLS R1853 ... 13

Size	Accuracy class	Part numbers for preload class	
		C2	C3
25 ¹⁾	P	–	–
	SP	–	–
35	P	R1853 322 13	R1853 332 13
	SP	–	R1853 331 13
45	P	R1853 422 13	R1853 432 13
	SP	–	R1853 431 13
55	P	R1853 522 13	R1853 532 13
	SP	–	R1853 531 13
65	P	R1853 622 13	R1853 632 13
	SP	–	R1853 631 13

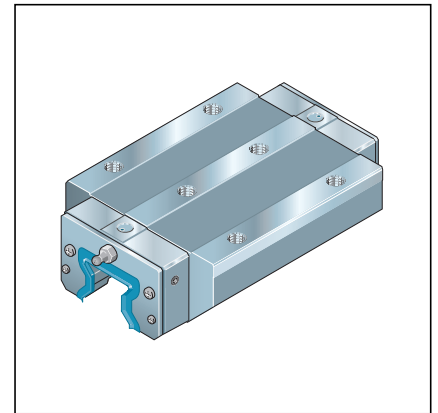

Runner block SNH R1821 ... 13

Size	Accuracy class	Part numbers for preload class	
		C2	C3
25 ¹⁾	P	–	–
	SP	–	–
35	P	R1821 322 13	R1821 332 13
	SP	–	R1821 331 13
45	P	R1821 422 13	R1821 432 13
	SP	–	R1821 431 13
55	P	R1821 522 13	R1821 532 13
	SP	–	R1821 531 13

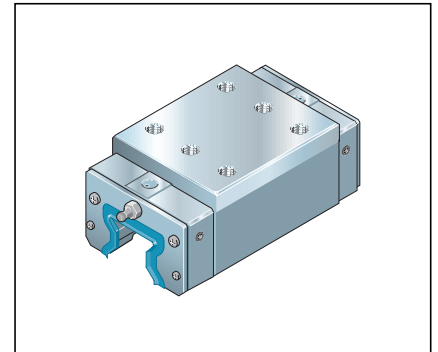

Runner block SLH R1824 ... 13 Size 65: SLS R1824 ... 13

Size	Accuracy class	Part numbers for preload class	
		C2	C3
25 ¹⁾	P	–	–
	SP	–	–
35	P	R1824 322 13	R1824 332 13
	SP	–	R1824 331 13
45	P	R1824 422 13	R1824 432 13
	SP	–	R1824 431 13
55	P	R1824 522 13	R1824 532 13
	SP	–	R1824 531 13
65	P	R1824 622 13	R1824 632 13
	SP	–	R1824 631 13

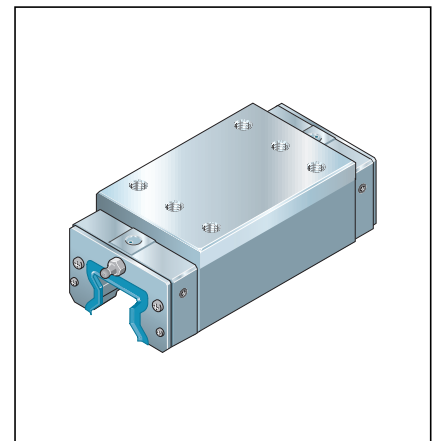

1) Size 25 in preparation

Standard Runner Blocks, Steel version

Runner Blocks for Oil and Grease Lubrication From Above

General notes on runner blocks R18.. ... 16

With open lube ports or integrated lube adapters for oil and grease lubrication from above

For part numbers, see the following page.
For dimensions, load capacities, rigidity and moment loads, please refer to the corresponding runner blocks R18.. ... 10.

Special feature:

Runner blocks R18.. ... 16 have been prepared for oil and grease lubrication from above. In the high runner blocks S.H, the vertical clearance between the end caps and an attachment mounting surface with integrated lube adapters has been designed for ease of maintenance.

How to recognize them:

The top lube holes at both ends have already been opened, but they are closed with screws for shipment (O-rings for sealing the lube fittings are provided with the runner blocks).

Runner block short names

FNS = Flanged, normal, standard height
FLS = Flanged, long, standard height
SNH = Slimline, normal, high
SLH = Slimline, long, high
SLS = Slimline, long, standard height

Preload classes

C2 = preload 8% C
C3 = preload 13% C

Lube fitting at the top

For lubrication from above, remove screw plug and insert an O-ring seal:
– Sizes 35 and 55: dia. 7 · 1.5 (mm)
– Sizes 45 and 65: dia. 10 · 1.5 (mm)

Integrated lube adapter for high runner blocks

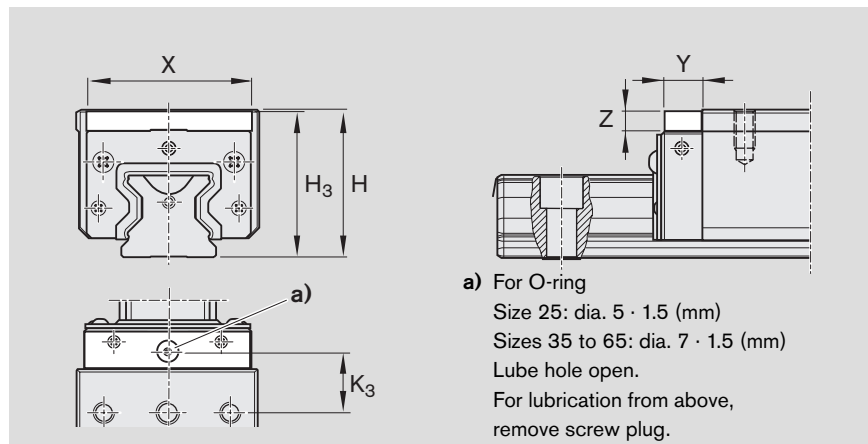

Size	Dimensions for integrated lube adapter (mm)				X	Y	Z
	H	H ₃	K ₃ ¹⁾	K ₃ ²⁾			
25	40	39.6	19.1	20.6	41.7	12.5	4.3
35	55	54.6	21.55	22.55	61.7	16.1	7.4
45	70	69.6	27.65	33.9	75.8	18.2	10.4
55	80	79.6	31.75	41.25	89.3	20.3	10.2

1) Dimension K₃ for runner block SNH (slimline, normal, high)

2) Dimension K₃ for runner block SLH (slimline, long, high)

Runner Blocks, Resist CR (optional)

For corrosion-resistant runner blocks, Resist CR, matte silver hard chrome plated, see section on "Standard Runner Blocks, Resist CR".

Standard Runner Blocks, Steel version

Runner Blocks for Oil and Grease Lubrication From Above

Runner block FNS R1851 ... 16

Size	Accuracy class	Part numbers for preload class	
		C2	C3
25	P	R1851 222 16	R1851 232 16
	SP	R1851 221 16	R1851 231 16
35	P	R1851 322 16	R1851 332 16
	SP	R1851 321 16	R1851 331 16
45	P	R1851 422 16	R1851 432 16
	SP	R1851 421 16	R1851 431 16
55	P	R1851 522 16	R1851 532 16
	SP	R1851 521 16	R1851 531 16
65	P	R1851 622 16	R1851 632 16
	SP	R1851 621 16	R1851 631 16

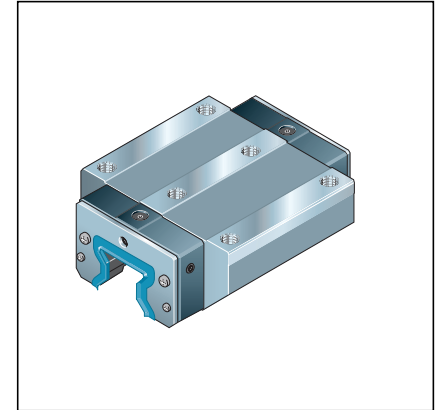

Runner block FLS R1853 ... 16

Size	Accuracy class	Part numbers for preload class	
		C2	C3
25	P	R1853 222 16	R1853 232 16
	SP	R1853 221 16	R1853 231 16
35	P	R1853 322 16	R1853 332 16
	SP	R1853 321 16	R1853 331 16
45	P	R1853 422 16	R1853 432 16
	SP	R1853 421 16	R1853 431 16
55	P	R1853 522 16	R1853 532 16
	SP	R1853 521 16	R1853 531 16
65	P	R1853 622 16	R1853 632 16
	SP	R1853 621 16	R1853 631 16

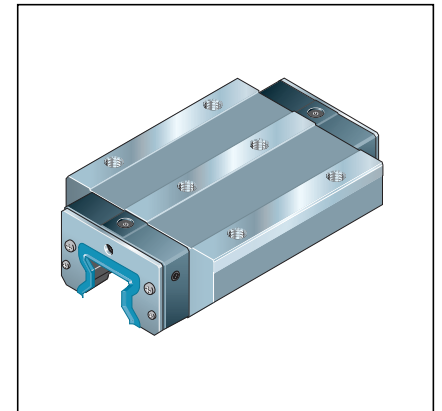

Runner block SNH R1821 ... 16

Size	Accuracy class	Part numbers for preload class	
		C2	C3
25	P	R1821 222 16	R1821 232 16
	SP	R1821 221 16	R1821 231 16
35	P	R1821 322 16	R1821 332 16
	SP	R1821 321 16	R1821 331 16
45	P	R1821 422 16	R1821 432 16
	SP	R1821 421 16	R1821 431 16
55	P	R1821 522 16	R1821 532 16
	SP	R1821 521 16	R1821 531 16

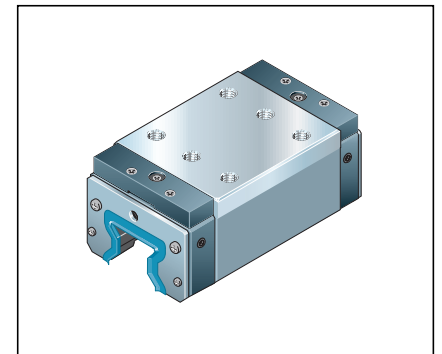

Runner block SLH R1824 ... 16

Size ¹⁾	Accuracy class	Part numbers for preload class	
		C2	C3
25	P	R1824 222 16	R1824 232 16
	SP	R1824 221 16	R1824 231 16
35	P	R1824 322 16	R1824 332 16
	SP	R1824 321 16	R1824 331 16
45	P	R1824 422 16	R1824 432 16
	SP	R1824 421 16	R1824 431 16
55	P	R1824 522 16	R1824 532 16
	SP	R1824 521 16	R1824 531 16

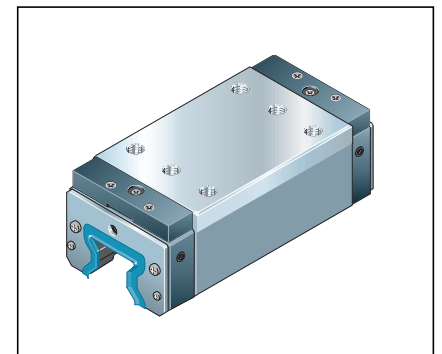

1) Size 65: SLS R1824 ... 16 (standard height, i.e. without lube adapter) on request

Standard Runner Blocks, Steel version

Runner Blocks for Central Oil Lubrication Systems

General notes on runner blocks R18.. ... 17

With smaller lube ducts (exclusively) for central oil lubrication via dosing valves

For part numbers, see the following page.
For dimensions, load capacities, rigidity and moment loads, please refer to the corresponding runner blocks R18.. ... 10.

Special feature:
Runner blocks R18.. ... 17 have smaller lube ducts. They need only small quantities of lube oil even when wall-mounted and are therefore suitable for all mounting orientations.

How to recognize them:
The end caps are gray. In the high runner blocks S.H, the vertical clearance between the end caps and an attachment mounting surface with integrated lube adapters has been designed for ease of maintenance. The top lube holes have already been opened, but they are closed with screws for shipment (O-rings for sealing the lube fittings are provided with the runner blocks).

Runner block short names
FNS = Flanged, normal, standard height
FLS = Flanged, long, standard height
SNH = Slimline, normal, high
SLH = Slimline, long, high

Preload classes
C2 = preload 8% C
C3 = preload 13% C

Lube fitting at the top

For lubrication from above, remove screw plug and insert an O-ring seal:
– Sizes 35 and 55: dia. 7 · 1.5 (mm)
– Sizes 45 and 65: dia. 10 · 1.5 (mm)

Integrated lube adapter for high runner blocks

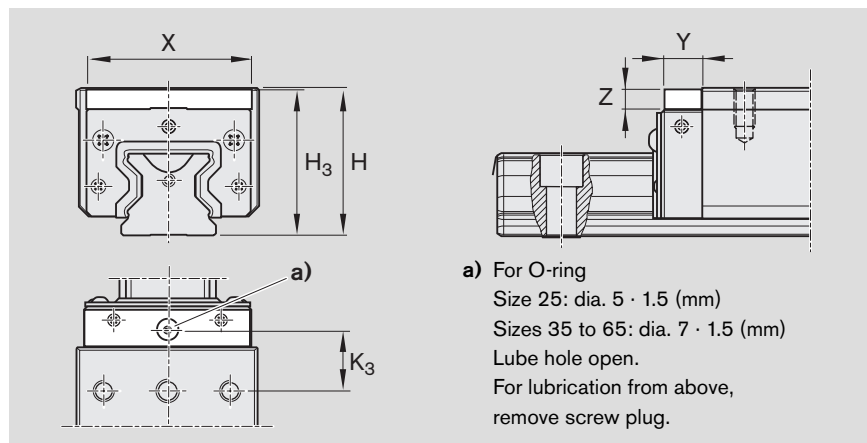

Size	Dimensions for integrated lube adapter (mm)						
	H	H ₃	K ₃ ¹⁾	K ₃ ²⁾	X	Y	Z
25	40	39.6	19.1	20.6	41.7	12.5	4.3
35	55	54.6	21.55	22.55	61.7	16.1	7.4
45	70	69.6	27.65	33.9	75.8	18.2	10.4
55	80	79.6	31.75	41.25	89.3	20.3	10.2

1) Dimension K₃ for runner block SNH (slimline, normal, high)

2) Dimension K₃ for runner block SLH (slimline, long, high)

Runner Blocks, Resist CR (optional)

For corrosion-resistant runner blocks, Resist CR, matte silver hard chrome plated, see section on "Standard Runner Blocks, Resist CR".

Standard Runner Blocks, Steel version

Runner Blocks for Central Oil Lubrication Systems

Runner block FNS R1851 ... 17

Size	Accuracy class	Part numbers for preload class	
		C2	C3
35	P	R1851 322 17	R1851 332 17
	SP	R1851 321 17	R1851 331 17
45	P	R1851 422 17	R1851 432 17
	SP	R1851 421 17	R1851 431 17
55	P	R1851 522 17	R1851 532 17
	SP	R1851 521 17	R1851 531 17

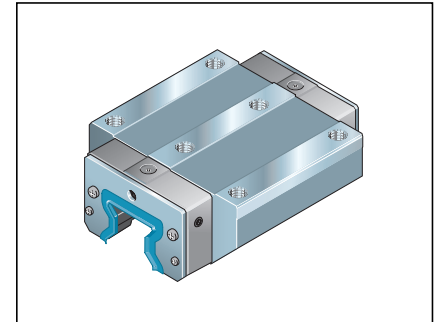

Runner block FLS R1853 ... 17

Size	Accuracy class	Part numbers for preload class	
		C2	C3
35	P	R1853 322 17	R1853 332 17
	SP	R1853 321 17	R1853 331 17
45	P	R1853 422 17	R1853 432 17
	SP	R1853 421 17	R1853 431 17
55	P	R1853 522 17	R1853 532 17
	SP	R1853 521 17	R1853 531 17

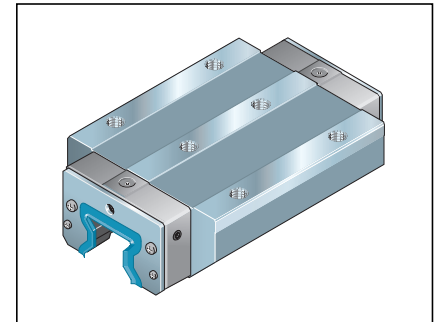

Runner block SNH R1821 ... 17

Size	Accuracy class	Part numbers for preload class	
		C2	C3
35	P	R1821 322 17	R1821 332 17
	SP	R1821 321 17	R1821 331 17
45	P	R1821 422 17	R1821 432 17
	SP	R1821 421 17	R1821 431 17
55	P	R1821 522 17	R1821 532 17
	SP	R1821 521 17	R1821 531 17

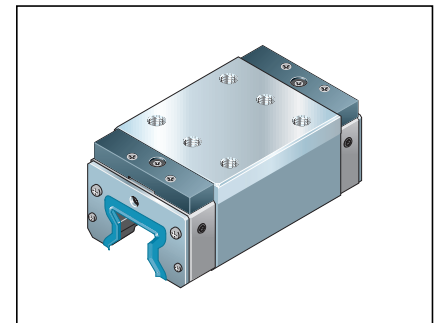

Runner block SLH R1824 ... 17

Size	Accuracy class	Part numbers for preload class	
		C2	C3
35	P	R1824 322 17	R1824 332 17
	SP	R1824 321 17	R1824 331 17
45	P	R1824 422 17	R1824 432 17
	SP	R1824 421 17	R1824 431 17
55	P	R1824 522 17	R1824 532 17
	SP	R1824 521 17	R1824 531 17

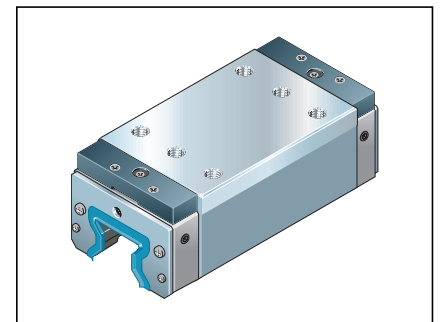

Standard Runner Blocks, Steel version

Runner Blocks for Wall Mounting

Runner Block FNS
R1851 ... 18
 Flanged, normal, standard height
 For wall mounting
 Oil lubrication via end faces

Notes

For lubrication, both lube holes of an end face must be used – to ensure proper lubrication of the upper and lower raceways. For short-stroke applications, lubricant must be applied via both end faces (four lube holes). There are no lube holes on the attachment mounting surface or the sides of the runner block.

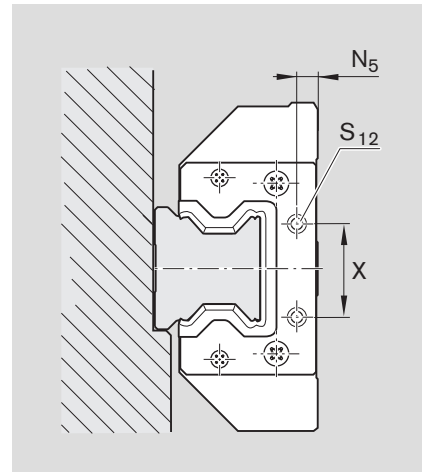
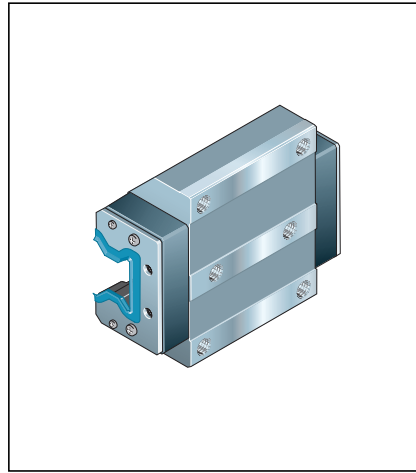

Size	Accuracy class ¹⁾	Part numbers for preload class		Dimensions of lube holes ²⁾ (mm)		
		C2	C3	N ₅	S ₁₂	X
35	P	R1851 322 18	R1851 332 18	7	M6	32
	SP	–	R1851 331 18			
45	P	R1851 422 18	R1851 432 18	8	M6	40
	SP	–	R1851 431 18			
55	P	R1851 522 18	R1851 532 18	9	M6	50
	SP	–	R1851 531 18			

1) Accuracy class UP on request

Runner Block FLS
R1853 ... 18
 Flanged, long, standard height

For wall mounting
 Oil lubrication via end faces

Notes

For lubrication, both lube holes of an end face must be used – to ensure proper lubrication of the upper and lower raceways. For short-stroke applications, lubricant must be applied via both end faces (four lube holes). There are no lube holes on the attachment mounting surface or the sides of the runner block.

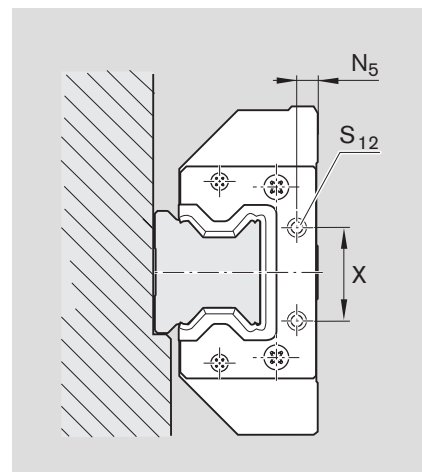
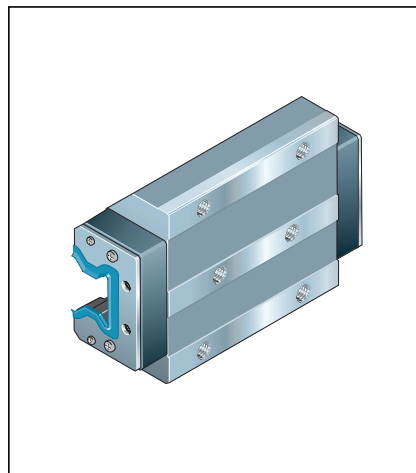

Size	Accuracy class ¹⁾	Part numbers for preload class		Dimensions of lube holes ²⁾ (mm)		
		C2	C3	N ₅	S ₁₂	X
35	P	R1853 322 18	R1853 332 18	7	M6	32
	SP	–	R1853 331 18			
45	P	R1853 422 18	R1853 432 18	8	M6	40
	SP	–	R1853 431 18			
55	P	R1853 522 18	R1853 532 18	9	M6	50
	SP	–	R1853 531 18			

1) Accuracy class UP on request

2) For other dimensions, load capacities, rigidity and moment loads, please refer to runner blocks FLS R1853 ... 10.

Preload classes

C2 = preload 8% C
 C3 = preload 13% C

Standard Runner Blocks, Steel version

Runner Blocks for Wall Mounting

Size 65:
Runner block FLS
R1859 620 31
Flanged, long, standard height

For wall mounting
Liquid grease or oil lubrication either at both end faces or at both ends of the attachment mounting surface

Notes
 A lube fitting is required on each of the blue end caps (**either** on the end face **or** at the attachment mounting surface) for liquid grease or oil lubrication – to ensure proper lubrication of the upper and lower raceways.

The side holes (c) cannot be used!

The lube holes (b) on the attachment mounting surface have already been opened, but they are closed with screws for shipment (O-rings for sealing the lube fittings are provided with the runner blocks).

Please adhere to the required lubricant quantities per pulse (see “Lubrication” section).

For dimensions, load capacities, rigidity and moment loads, please refer to runner blocks FLS R1853 621 10.

Preload class
 C3 = preload 13% C

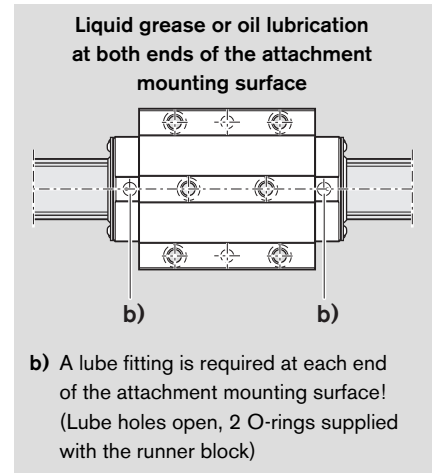
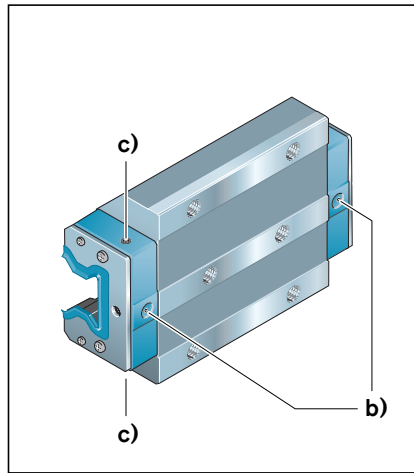
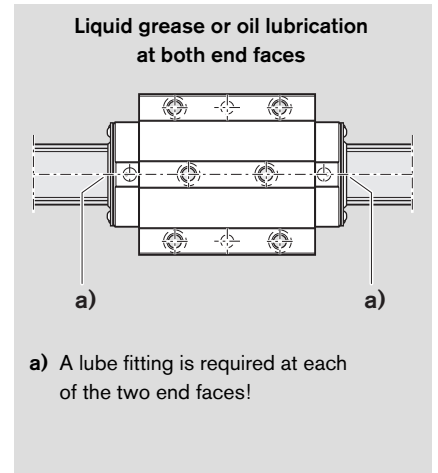
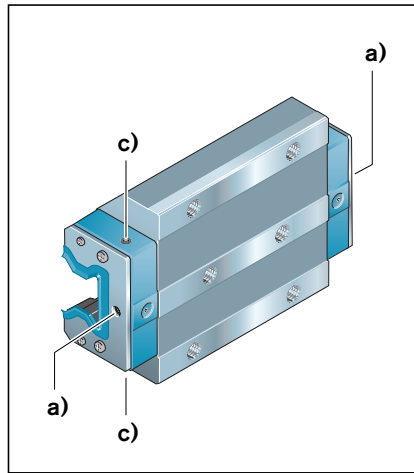

Size	Accuracy class	Part numbers for preload class
65	SP	C3 R1859 620 31

Standard Runner Blocks, Steel version

Runner Blocks for Wall Mounting

Runner block SNH R1821 ... 18 Slimline, normal, high

For wall mounting
Oil lubrication via end faces

Notes

For lubrication, both lube holes of an end face must be used – to ensure proper lubrication of the upper and lower raceways. For short-stroke applications, lubricant must be applied via both end faces (four lube holes). There are no lube holes on the attachment mounting surface or the sides of the runner block.

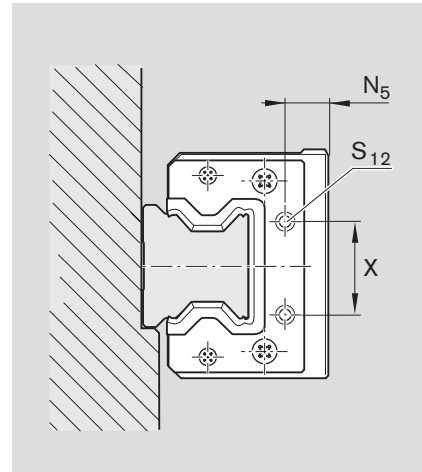
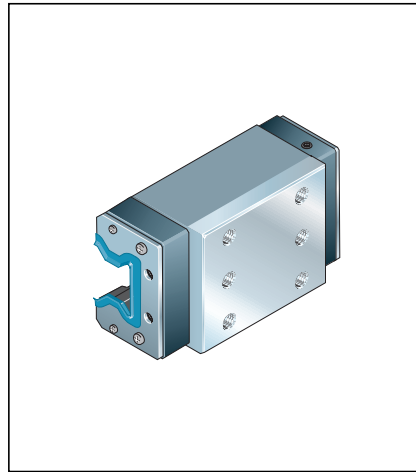

Size	Accuracy class ¹⁾	Part numbers for preload class		Dimensions of lube holes ²⁾ (mm)		
		C2	C3	N ₅	S ₁₂	X
35	P	R1821 322 18	R1821 332 18	14	M6	32
	SP	–	R1821 331 18			
45	P	R1821 422 18	R1821 432 18	18	M6	40
	SP	–	R1821 431 18			
55	P	R1821 522 18	R1821 532 18	19	M6	50
	SP	–	R1821 531 18			

1) Accuracy class UP on request

2) For other dimensions, load capacities, rigidity and moment loads, please refer to runner blocks SNH R1821 ... 10.

Preload classes

C2 = preload 8% C

C3 = preload 13% C

Standard Runner Blocks, Steel version

Runner Blocks for Wall Mounting

Runner block SLH R1824 ... 18 Slimline, long, high

For wall mounting
Oil lubrication via end faces

Notes

For lubrication, both lube holes of an end face must be used – to ensure proper lubrication of the upper and lower raceways. For short-stroke applications, lubricant must be applied via both end faces (four lube holes). There are no lube holes on the attachment mounting surface or the sides of the runner block.

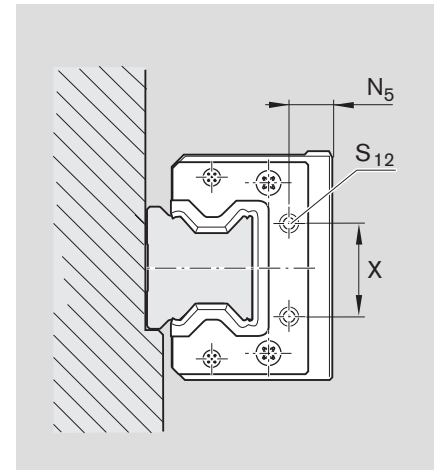
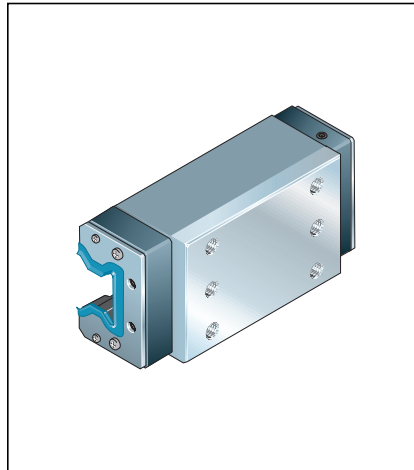

Size	Accuracy class ¹⁾	Part numbers for preload class		Dimensions of lube holes ²⁾ (mm)		
		C2	C3	N ₅	S ₁₂	X
35	P	R1824 322 18	R1824 332 18	14	M6	32
	SP	–	R1824 331 18			
45	P	R1824 422 18	R1824 432 18	18	M6	40
	SP	–	R1824 431 18			
55	P	R1824 522 18	R1824 532 18	19	M6	50
	SP	–	R1824 531 18			

1) Accuracy class UP on request

2) For other dimensions, load capacities, rigidity and moment loads, please refer to runner blocks SLH R1824 ... 10.

Preload classes

C2 = preload 8% C

C3 = preload 13% C

Standard Runner Blocks, Resist CR version

Runner Blocks

General notes on runner blocks R18.. ...6. Resist CR

For part numbers, see the following pages. For dimensions, load capacities, rigidity and moment loads, please refer to the corresponding runner blocks R18.. ... 10.
For notes on special features, please refer to runner blocks R18.. ... 1.

Runner block short names

FNS = Flanged, normal, standard height
FLS = Flanged, long, standard height
SNH = Slimline, normal, high
SLH = Slimline, long, high
SLS = Slimline, long, standard height

Corrosion-resistant coating Resist CR: matte silver hard chrome plated

Runner blocks R18.. ... 6. with corrosion-resistant coating Resist CR, matte silver hard chrome plated, replace the runner blocks with zinc-iron coating.

Preload class

C2 = preload 8% C

Different tolerances for Resist CR coating

Caution!

For runner blocks and guide rails in Resist CR, matte silver hard chrome plated, different tolerances apply for the dimensions H and A_3 (see "Accuracy classes and their tolerances").

Higher preload for combinations of hard chrome plated runner blocks with hard chrome plated guide rails

When hard chrome plated runner blocks with preload C2 = 8% C are combined with hard chrome plated guide rails, the preload increases to approx. 10% C.

Standard Runner Blocks, Resist CR version

Runner Blocks

Runner block FNS R1851 ... 60

Size	Accuracy class ¹⁾	Part numbers for preload class C2
25	H	R1851 223 60
35	H	R1851 323 60
45	H	R1851 423 60
55	H	R1851 523 60
65	H	R1851 623 60

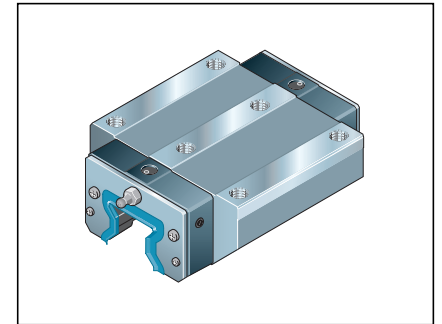

Runner block FLS R1853 ... 60

Size	Accuracy class ¹⁾	Part numbers for preload class C2
25	H	R1853 223 60
35	H	R1853 323 60
45	H	R1853 423 60
55	H	R1853 523 60
65	H	R1853 623 60

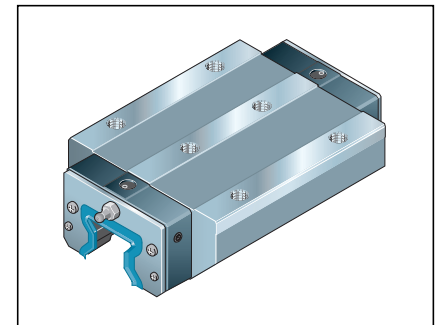

Runner block SNH R1821 ... 60

Size	Accuracy class ¹⁾	Part numbers for preload class C2
25	H	R1821 223 60
35	H	R1821 323 60
45	H	R1821 423 60
55	H	R1821 523 60

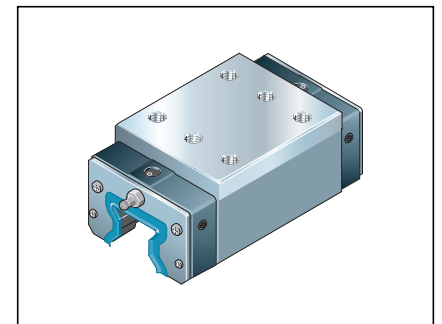

Runner block SLH R1824 ... 60

Size	Accuracy class ¹⁾	Part numbers for preload class C2
25	H	R1824 223 60
35	H	R1824 323 60
45	H	R1824 423 60
55	H	R1824 523 60
65	H	R1824 623 60

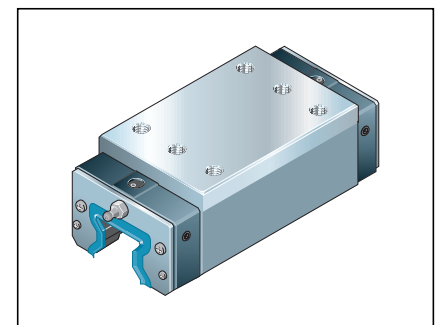

1) Accuracy classes P and SP on request

Caution!

Please read the general notes on runner blocks R18.. ... 6., Resist CR version!

Standard Runner Blocks, Resist CR version

Runner Blocks with Aluminum End Caps

Size	Accuracy class ¹⁾	Part numbers for preload class C2
25 ²⁾	H	–
35	H	R1851 323 63
45	H	R1851 423 63
55	H	R1851 523 63
65	H	R1851 623 63

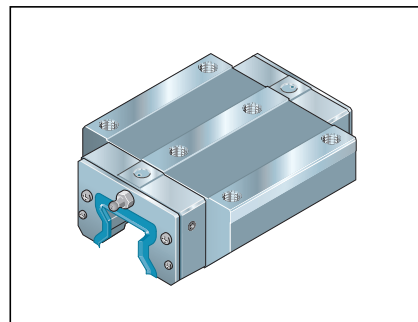

Runner block FLS R1853 ... 63

Size	Accuracy class ¹⁾	Part numbers for preload class C2
25 ²⁾	H	–
35	H	R1853 323 63
45	H	R1853 423 63
55	H	R1853 523 63
65	H	R1853 623 63

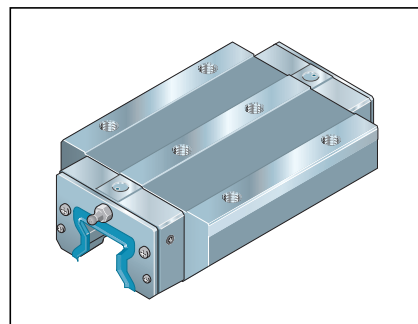

Runner block SNH R1821 ... 63

Size	Accuracy class ¹⁾	Part numbers for preload class C2
25 ²⁾	H	–
35	H	R1821 323 63
45	H	R1821 423 63
55	H	R1821 523 63

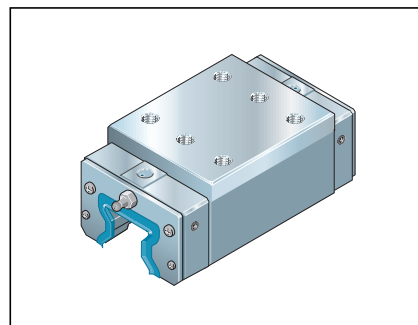

Runner block SLH R1824 ... 63 Size 65: SLS R1824 ... 63

Size	Accuracy class ¹⁾	Part numbers for preload class C2
25 ²⁾	H	–
35	H	R1824 323 63
45	H	R1824 423 63
55	H	R1824 523 63
65	H	R1824 623 63

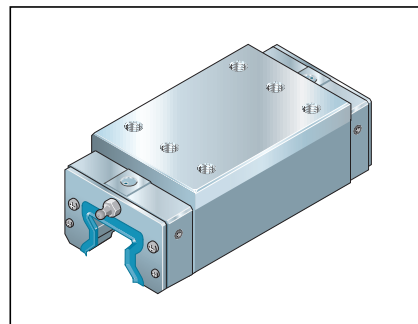

1) Accuracy classes P and SP on request

2) Size 25 in preparation

Caution!

Please read the general notes on runner blocks R18... .. 6., Resist CR version!

For notes on special features, please refer to runner blocks R18... .. 13.

Standard Runner Blocks, Resist CR version

Runner Blocks for Oil and Grease Lubrication From Above

Runner block FNS R1851 ... 66

Size	Accuracy class ¹⁾	Part numbers for preload class C2
25	H	R1851 223 66
35	H	R1851 323 66
45	H	R1851 423 66
55	H	R1851 523 66
65	H	R1851 623 66

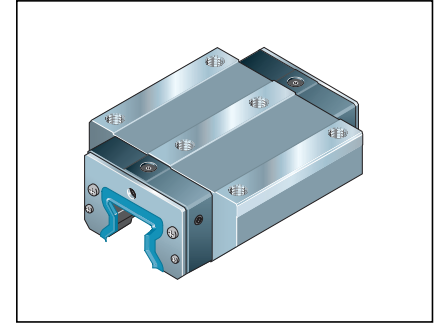

Runner block FLS R1853 ... 66

Size	Accuracy class ¹⁾	Part numbers for preload class C2
25	H	R1853 223 66
35	H	R1853 323 66
45	H	R1853 423 66
55	H	R1853 523 66
65	H	R1853 623 66

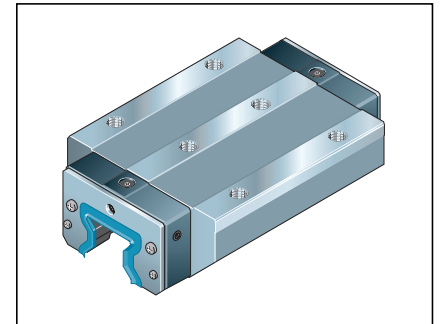

Runner block SNH R1821 ... 66

Size	Accuracy class ¹⁾	Part numbers for preload class C2
25	H	R1821 223 66
35	H	R1821 323 66
45	H	R1821 423 66
55	H	R1821 523 66

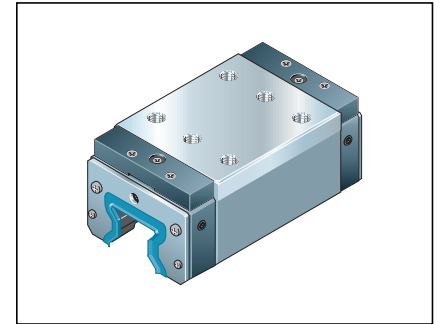

Runner block SLH R1824 ... 66

Size	Accuracy class ¹⁾	Part numbers for preload class C2
25	H	R1824 223 66
35	H	R1824 323 66
45	H	R1824 423 66
55	H	R1824 523 66

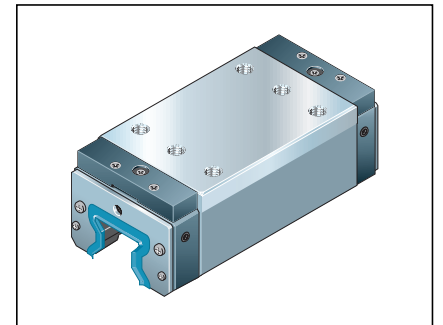

1) Accuracy classes P and SP on request

Caution!

Please read the general notes on runner blocks R18.. ... 6., Resist CR version!
For notes on special features, please refer to runner blocks R18.. ... 16.

Standard Runner Blocks, Resist CR version

Runner Blocks for Central Oil Lubrication Systems

Runner block FNS R1851 ... 67

Size	Accuracy class ¹⁾	Part numbers for preload class C2
35	H	R1851 323 67
45	H	R1851 423 67
55	H	R1851 523 67

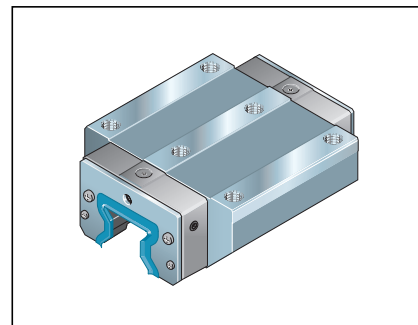

Runner block FLS R1853 ... 67

Size	Accuracy class ¹⁾	Part numbers for preload class C2
35	H	R1853 323 67
45	H	R1853 423 67
55	H	R1853 523 67

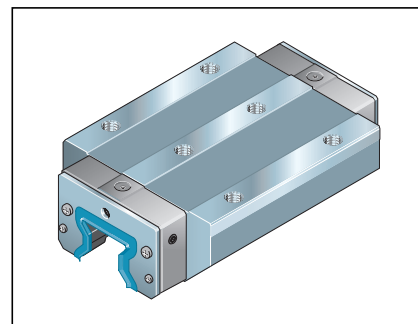

Runner block SNH R1821 ... 67

Size	Accuracy class ¹⁾	Part numbers for preload class C2
35	H	R1821 323 67
45	H	R1821 423 67
55	H	R1821 523 67

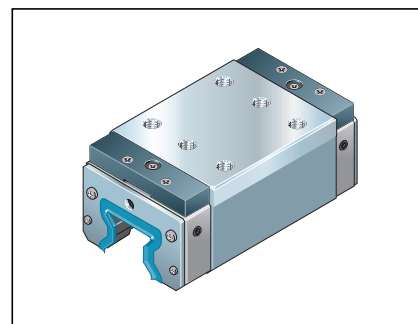

Runner block SLH R1824 ... 67

Size	Accuracy class ¹⁾	Part numbers for preload class C2
35	H	R1824 323 67
45	H	R1824 423 67
55	H	R1824 523 67

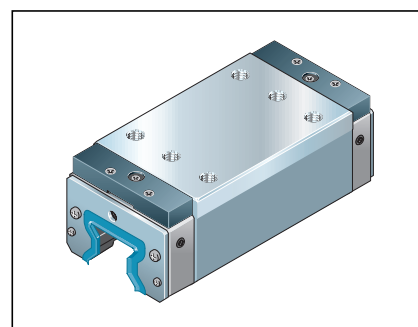

1) Accuracy classes P and SP on request

Caution!

Please read the general notes on runner blocks R18.. ... 6., Resist CR version!
For notes on special features, please refer to runner blocks R18.. ... 17.

Standard Runner Blocks, Resist CR version

Runner Blocks for Wall Mounting

Runner block FNS R1851 ... 68

Size	Accuracy class ¹⁾	Part numbers for preload class C2
35	H	R1851 323 68
45	H	R1851 423 68
55	H	R1851 523 68

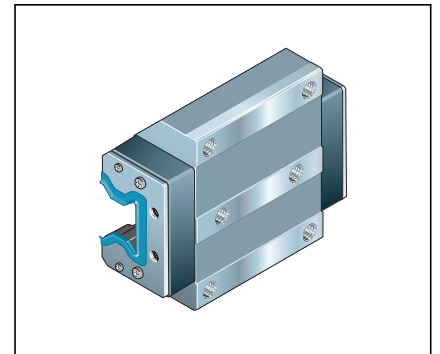

Runner block FLS R1853 ... 68

Size	Accuracy class ¹⁾	Part numbers for preload class C2
35	H	R1853 323 68
45	H	R1853 423 68
55	H	R1853 523 68

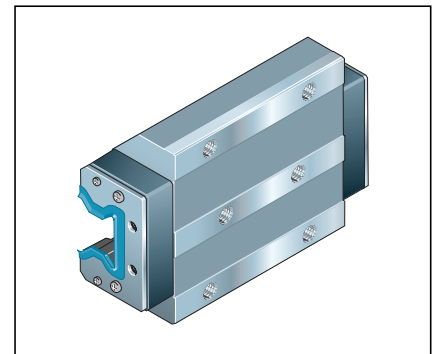

Runner block SNH R1821 ... 68

Size	Accuracy class ¹⁾	Part numbers for preload class C2
35	H	R1821 323 68
45	H	R1821 423 68
55	H	R1821 523 68

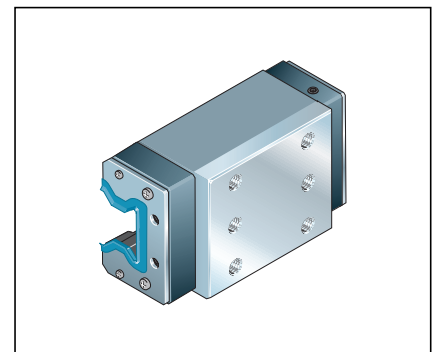

Runner block SLH R1824 ... 68

Size	Accuracy class ¹⁾	Part numbers for preload class C2
35	H	R1824 323 68
45	H	R1824 423 68
55	H	R1824 523 68

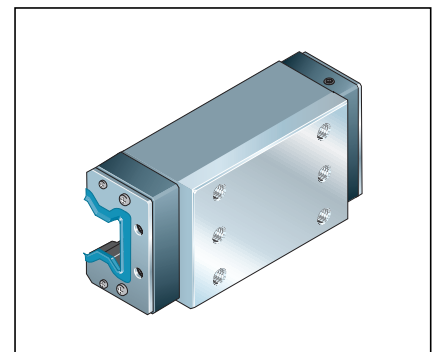

1) Accuracy classes P and SP on request

Caution!

Please read the general notes on runner blocks R18.. ... 6., Resist CR version!
For notes on special features, please refer to runner blocks R18.. ... 18.

Standard Guide Rails, Steel version

Product Description

Outstanding features

- Guide rails with hardened raceways and ground on all sides
- Corrosion-resistant guide rails in Resist CR, matte silver hard chrome plated, available in accuracy class H, accuracy classes P and SP on request

Proven cover strip for guide rail mounting holes

- A **single** cover for all holes – saves time and money
- Stainless spring steel to EN 10088
- Easy to fit – simply clip on and secure

Guide rails with cover strip and plastic screw-down protective end caps

- with tapped holes at the end faces

Alternatively:

Cover strip secured with screws and washers

Guide rails with cover strip and aluminum strip clamps

- without tapped holes at the end faces (not required)

Guide rails with plastic mounting hole plugs

Guide rails with steel mounting hole plugs

Guide rails for mounting from below

- with hardened top surface

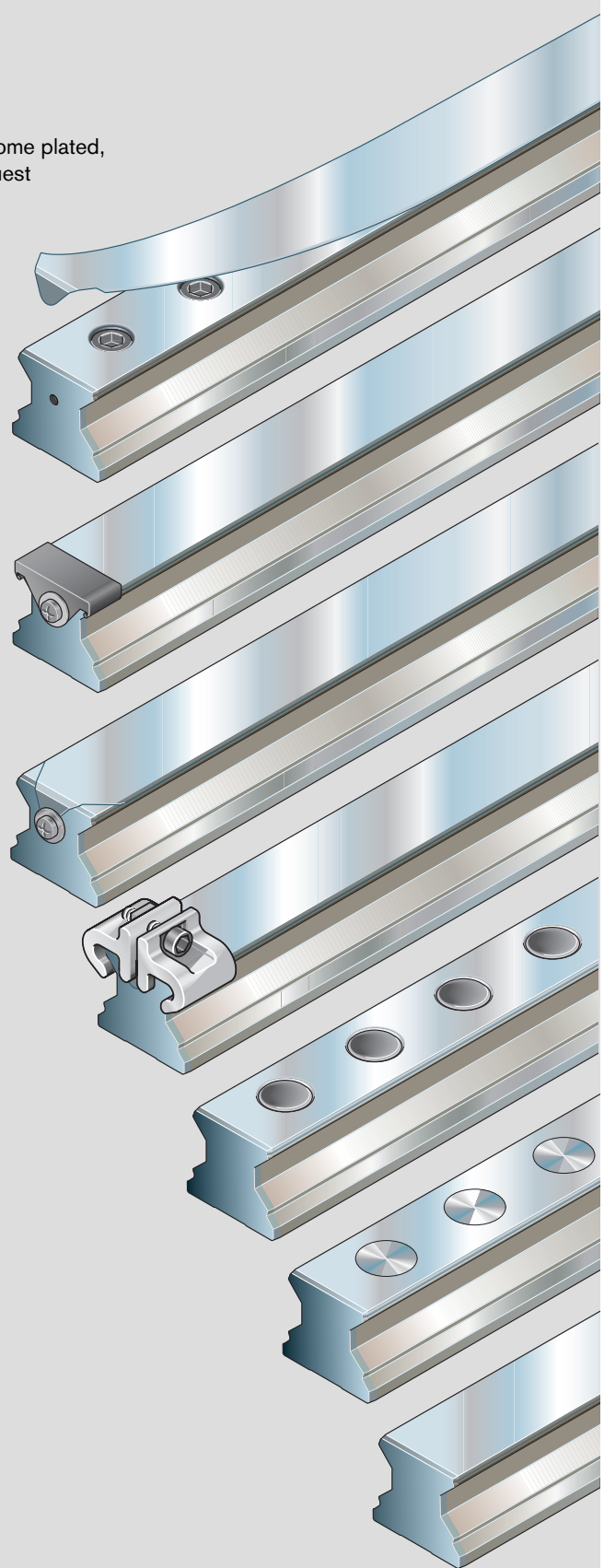

Standard Guide Rails, Steel version

Ordering Examples

Ordering guide rails in recommended lengths

The following examples apply to all orders for standard guide rails. Recommended rail lengths are delivered with priority.

Size	Accuracy class	Guide rail One-piece Part number, Rail length L (mm)	Composite Part number and number of sections, Rail length L (mm)	Spacing T ₂ mm	Recommended rail lengths Number of holes n _B / Rail length L (mm)
25	H	R1805 233 31, ...	R1805 233 3, ...	30	acc. to formula L = n _B · T ₂ - 4 up to 133/3986 max.
	P	R1805 232 31, ...	R1805 232 3, ...		
	SP	R1805 231 31, ...	R1805 231 3, ...		
	UP	R1805 239 31, ...	R1805 239 3, ...		
35	H	R1805 333 61, ...	R1805 333 6, ...	40	acc. to formula L = n _B · T ₂ - 4 up to 100/3996 max.
	P	R1805 332 61, ...	R1805 332 6, ...		
	SP	R1805 331 61, ...	R1805 331 6, ...		
	UP	R1805 339 61, ...	R1805 339 6, ...		
45	H	R1805 433 61, ...	R1805 433 6, ...	52.5	acc. to formula L = n _B · T ₂ - 4 up to 76/3986 max.
	P	R1805 432 61, ...	R1805 432 6, ...		
	SP	R1805 431 61, ...	R1805 431 6, ...		
	UP	R1805 439 61, ...	R1805 439 6, ...		
55	H	R1805 533 61, ...	R1805 533 6, ...	60	acc. to formula L = n _B · T ₂ - 4
	P	R1805 532 61, ...	R1805 532 6, ...		

Extract from table with part numbers and recommended rail lengths for ordering example

From the desired length to the recommended length

$$L = \frac{L_W}{T_2} \cdot T_2 - 4$$

Round up the quotient L_W/T₂ to the next whole number!

Example

$$L = \frac{1660 \text{ mm}}{40 \text{ mm}} \cdot 40 \text{ mm} - 4 \text{ mm}$$

$$L = 42 \cdot 40 \text{ mm} - 4 \text{ mm}$$

$$L = 1676 \text{ mm}$$

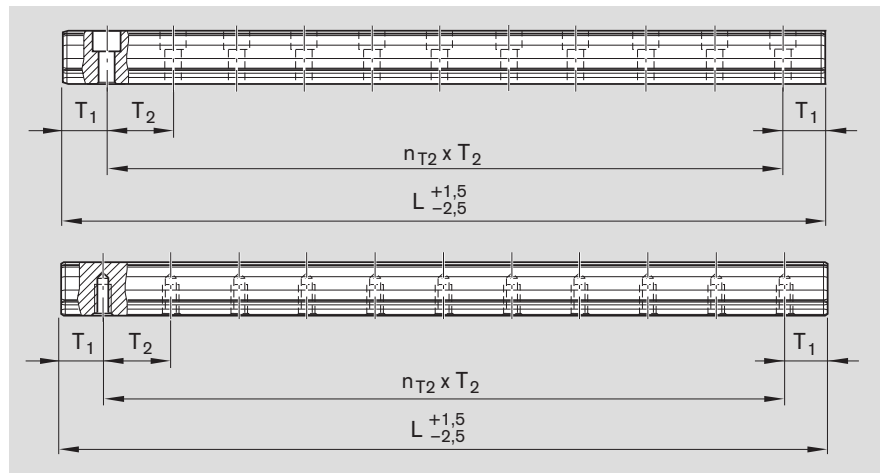

$$L = n_B \cdot T_2 - 4$$

Basis: number of holes

$$L = n_{T_2} \cdot T_2 + 2 \cdot T_{1S}$$

Basis: number of spaces

- L = recommended rail length (mm)
- L_W = desired rail length (mm)
- T₂ = hole spacing¹⁾ (mm)
- T_{1S} = preferred dimension¹⁾ (mm)
- n_B = number of holes
- n_{T₂} = number of spaces
- 1) See tables for values

Notes on ordering examples

If the preferred dimension T_{1S} cannot be used:

- Select an end space T₁ between T_{1S} and T_{1 min}.
- Do not go below the minimum spacing T_{1 min}! (T₁, T_{1 min}, T_{1S} are the same at either end of the rail.)

Ordering example 1 (up to L_{max})

- Standard guide rail size 35 with cover strip
- Accuracy class H
- Calculated rail length 1676 mm, (41 · T₂, preferred dimension T_{1S} = 18 mm; number of holes n_B = 42)

Ordering data

Part number, rail length (mm)
T₁ / n_{T₂} · T₂ / T₁ (mm)

R1805 333 61, 1676 mm
18 / 41 · 40 / 18 mm

Ordering example 2 (over L_{max})

- Standard guide rail size 35 with cover strip
- Accuracy class H
- Calculated rail length 5036 mm, 2 sections (125 · T₂, preferred dimension T_{1S} = 18 mm; number of holes n_B = 126)

Ordering data

Part number and number of sections, rail length (mm)
T₁ / n_{T₂} · T₂ / T₁ (mm)

R1875 333 62, 5036 mm
18 / 125 · 60 / 18 mm

Rail lengths greater than L_{max} are made up of matching rail sections mounted end to end.

Standard Guide Rails, Steel version

Guide Rails with Cover Strip and Protective End Caps

Guide rail R1805 .6. ..

For mounting from above,
with cover strip of stainless spring
steel to EN 10088 and screw-down
plastic protective caps

Notes

As an alternative, the cover strip can
be secured with screws and washers.
Follow the mounting instructions!
Send for the publication "Mounting
Instructions for the Cover Strip".

For corrosion-resistant guide rails,
Resist CR, matte silver hard chrome
plated, see section on "Standard
Guide Rails, Resist CR", part numbers
R1845 .6. ..

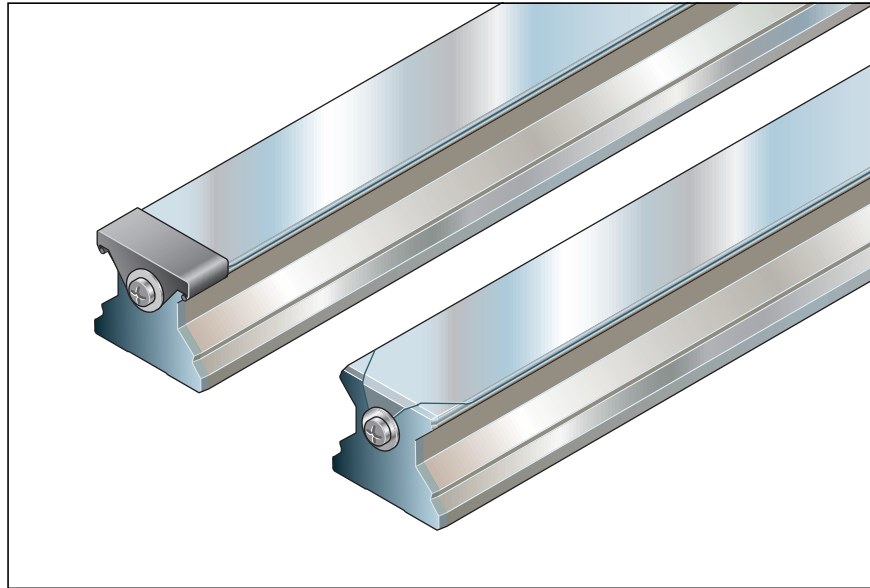

Size	Accuracy class	Guide rail One-piece Part number, Rail length L (mm)	Composite Part number and number of sections, Rail length L (mm)	Spacing T ₂ mm	Recommended rail lengths Number of holes n _B / Rail length L (mm)
25	H	R1805 263 31,	R1805 263 3.,	30	acc. to formula $L = n_B \cdot T_2 - 4$ up to 133/3986 max.
	P	R1805 262 31,	R1805 262 3.,		
	SP	R1805 261 31,	R1805 261 3.,		
	GP ¹⁾	R1805 268 31,	R1805 268 3.,		
	UP	R1805 269 31,	R1805 269 3.,		
35	H	R1805 363 61,	R1805 363 6.,	40	acc. to formula $L = n_B \cdot T_2 - 4$ up to 100/3996 max.
	P	R1805 362 61,	R1805 362 6.,		
	SP	R1805 361 61,	R1805 361 6.,		
	GP ¹⁾	R1805 368 61,	R1805 368 6.,		
	UP	R1805 369 61,	R1805 369 6.,		
45	H	R1805 463 61,	R1805 463 6.,	52.5	acc. to formula $L = n_B \cdot T_2 - 4$ up to 76/3986 max.
	P	R1805 462 61,	R1805 462 6.,		
	SP	R1805 461 61,	R1805 461 6.,		
	GP ¹⁾	R1805 468 61,	R1805 468 6.,		
	UP	R1805 469 61,	R1805 469 6.,		
55	H	R1805 563 61,	R1805 563 6.,	60	acc. to formula $L = n_B \cdot T_2 - 4$ up to 66/3956 max.
	P	R1805 562 61,	R1805 562 6.,		
	SP	R1805 561 61,	R1805 561 6.,		
	GP ¹⁾	R1805 568 61,	R1805 568 6.,		
	UP	R1805 569 61,	R1805 569 6.,		
65	H	R1805 663 61,	R1805 663 6.,	75	acc. to formula $L = n_B \cdot T_2 - 4$ up to 53/3971 max.
	P	R1805 662 61,	R1805 662 6.,		
	SP	R1805 661 61,	R1805 661 6.,		
	GP ¹⁾	R1805 668 61,	R1805 668 6.,		
	UP	R1805 669 61,	R1805 669 6.,		

1) For accuracy class GP (guide rails sorted by height), see "Selection of Accuracy Classes".
Guide rails in accuracy class GP in lengths of up to 4000 mm only.

Standard guide rails R1805 .6. ..

Securing of cover strip with plastic screw-down protective caps or alternatively with screws and washers (included in the supply scope).

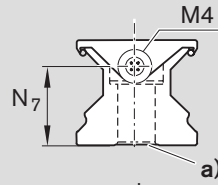

a) Due to manufacturing reasons, guide rails in accuracy class H may not have a slot on the base.
For mounting on mineral cast beds, guide rails with a flat base (without slot) are available in accuracy classes P and SP on request.

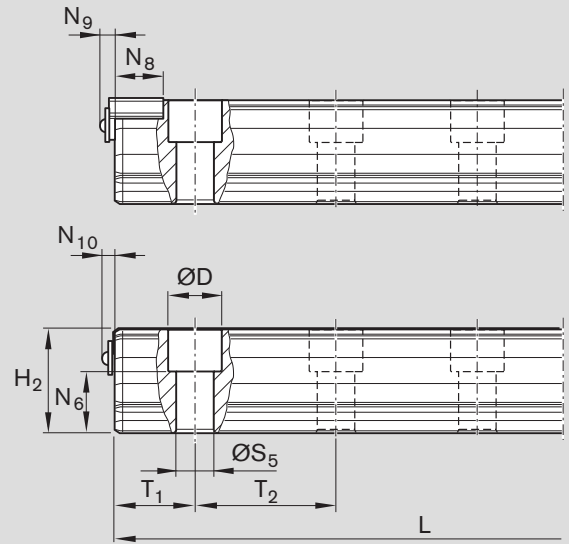
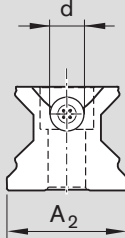

Size	Dimensions (mm)															Weight (kg/m)
	A ₂	d	D	H ₂ ¹⁾	L _{max} ²⁾	N ₆ ^{±0.5}	N ₇	N ₈	N ₉	N ₁₀	S ₅	T _{1 min} ³⁾	T _{1S} ⁴⁾	T ₂		
25	23	12	11	23.60	4000	14.3	15	15.2	6.5	4.10	7	13	13.00	30.0	3.1	
35	34	15	15	31.10	4000	19.4	22	18.0	7.0	4.10	9	16	18.00	40.0	6.3	
45	45	15	20	39.10	4000	22.4	30	20.0	7.0	4.10	14	18	24.25	52.5	10.3	
55	53	20	24	47.85	4000	28.7	30	20.0	7.0	4.35	16	20	28.00	60.0	13.1	
65	63	20	26	58.15	4000	36.5	40	20.0	7.0	4.35	18	21	35.50	75.0	17.4	

- 1) Dimension H₂ with cover strip
Size 25 with 0.2 mm cover strip
Sizes 35 to 65 with 0.3 mm cover strip
- 2) For sizes 35 to 65 in accuracy class H and P, one-piece guide rails up to approx. 6000 mm in length can be supplied in special cases.
For availability of accuracy class SP, please consult us. Guide rails in accuracy class GP in lengths of up to 4000 mm only.
- 3) Rails with T₁ smaller than T_{1 min} have no tapped hole at the end face for securing the strip! Secure the cover strip! Please refer to the mounting instructions.
- 4) Preferred dimension T_{1S} with tolerances +0.5/-1.0

Standard Guide Rails, Steel version

Guide Rails with Cover Strip and Strip Clamps

Guide rail R1805 .3. ..

For mounting from above,
with cover strip of stainless spring
steel to EN 10088
and aluminum strip clamps

Notes

Secure the cover strip!
Strip clamps are included in the supply
scope.
Please follow the mounting instructions!
Send for the publication "Mounting
Instructions for the Cover Strip".

For corrosion-resistant guide rails,
Resist CR, matte silver hard chrome
plated, see section on "Standard
Guide Rails, Resist CR", part numbers
R1845 .3. ..

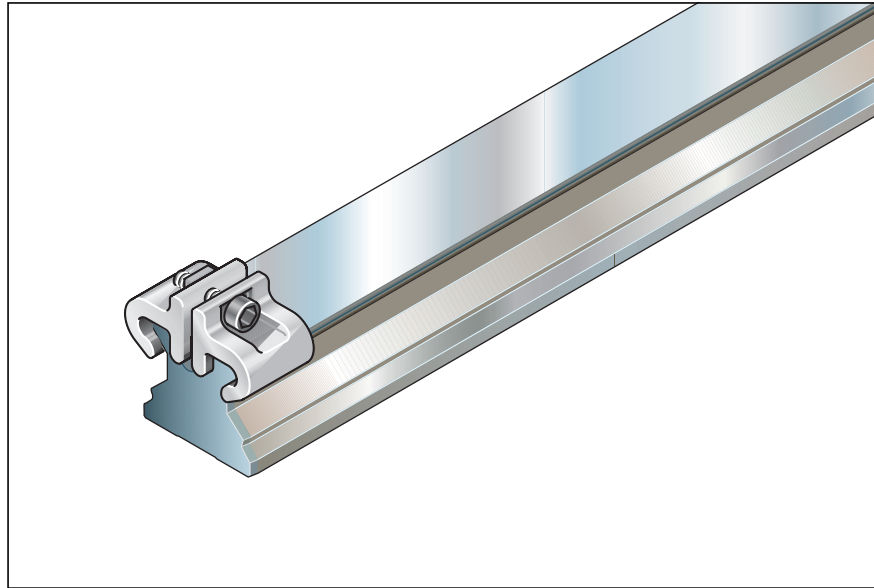

Size	Accuracy class	Guide rail		Spacing T_2 mm	Recommended rail lengths Number of holes n_B / Rail length L (mm)
		One-piece Part number, Rail length L (mm)	Composite Part number and number of sections, Rail length L (mm)		
25	H	R1805 233 31,	R1805 233 3.,	30	acc. to formula $L = n_B \cdot T_2 - 4$ up to 133/3986 max.
	P	R1805 232 31,	R1805 232 3.,		
	SP	R1805 231 31,	R1805 231 3.,		
	UP	R1805 239 31,	R1805 239 3.,		
35	H	R1805 333 61,	R1805 333 6.,	40	acc. to formula $L = n_B \cdot T_2 - 4$ up to 100/3996 max.
	P	R1805 332 61,	R1805 332 6.,		
	SP	R1805 331 61,	R1805 331 6.,		
	UP	R1805 339 61,	R1805 339 6.,		
45	H	R1805 433 61,	R1805 433 6.,	52.5	acc. to formula $L = n_B \cdot T_2 - 4$ up to 76/3986 max.
	P	R1805 432 61,	R1805 432 6.,		
	SP	R1805 431 61,	R1805 431 6.,		
	UP	R1805 439 61,	R1805 439 6.,		
55	H	R1805 533 61,	R1805 533 6.,	60	acc. to formula $L = n_B \cdot T_2 - 4$ up to 66/3956 max.
	P	R1805 532 61,	R1805 532 6.,		
	SP	R1805 531 61,	R1805 531 6.,		
	UP	R1805 539 61,	R1805 539 6.,		
65	H	R1805 633 61,	R1805 633 6.,	75	acc. to formula $L = n_B \cdot T_2 - 4$ up to 53/3971 max.
	P	R1805 632 61,	R1805 632 6.,		
	SP	R1805 631 61,	R1805 631 6.,		
	UP	R1805 639 61,	R1805 639 6.,		

Standard guide rails R1805 .3. ..

Guide rail with cover strip without tapped holes at the end faces (not required for strip clamps).
Cover strip secured with strip clamps (included).

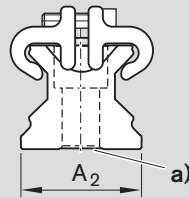

a) Due to manufacturing reasons, guide rails in accuracy class H may not have a slot on the base.
For mounting on mineral cast beds, guide rails with a flat base (without slot) are available in accuracy classes P and SP on request.

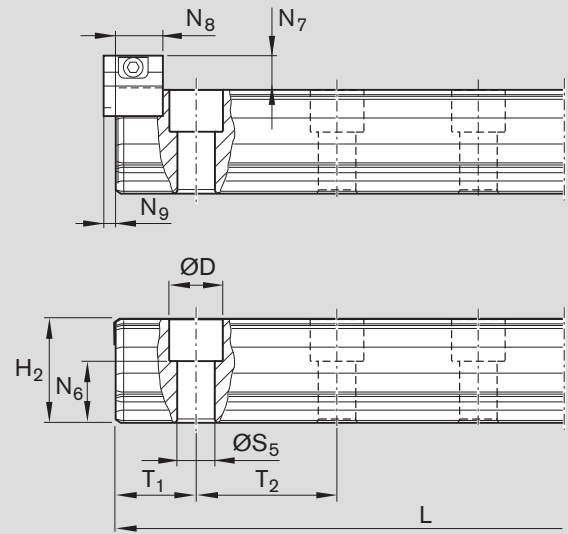

Size	Dimensions (mm)												Weight kg/m
	A ₂	D	H ₂ ¹⁾	L _{max} ²⁾	N ₆ ^{±0.5}	N ₇ ³⁾	N ₈	N ₉	S ₅	T _{1 min}	T _{1S} ⁴⁾	T ₂	
25	23	11	23.60	4000	14.3	8.2	13	2.0	7	13	13.00	30.0	3.1
35	34	15	31.10	4000	19.4	11.7	16	2.2	9	16	18.00	40.0	6.3
45	45	20	39.10	4000	22.4	12.5	18	2.2	14	18	24.25	52.5	10.3
55	53	24	47.85	4000	28.7	14.0	17	3.2	16	20	28.00	60.0	13.1
65	63	26	58.15	4000	36.5	15.0	17	3.2	18	21	35.50	75.0	17.4

- 1) Dimension H₂ with cover strip
Size 25 with 0.2 mm cover strip
Sizes 35 to 65 with 0.3 mm cover strip
- 2) For sizes 35 to 65 in accuracy class H and P, one-piece guide rails up to approx. 6000 mm in length can be supplied in special cases.
For availability of accuracy class SP, please consult us.
- 3) Dimension N₇ with cover strip
- 4) Preferred dimension T_{1S} with tolerances +0.5/-1.0

Standard Guide Rails, Steel version

Guide Rails for Cover Strip

Guide rail R1805 .2. ..

For mounting from above,
for cover strip
(not included)

Notes

The cover strip and strip clamps or protective caps must be ordered separately. For part numbers and dimensions see "Accessories".

For corrosion-resistant guide rails, Resist CR, matte silver hard chrome plated, see section on "Standard Guide Rails, Resist CR", part numbers R1845 .7. ..

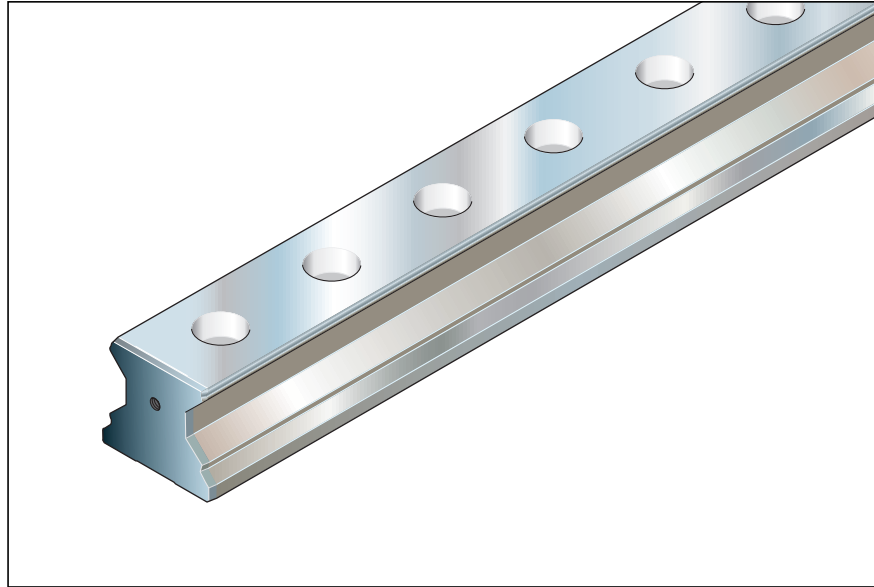

Size	Accuracy class	Guide rail		Spacing T_2 mm	Recommended rail lengths Number of holes n_B / Rail length L (mm)
		One-piece Part number, Rail length L (mm)	Composite Part number and number of sections, Rail length L (mm)		
25	H	R1805 223 31,	R1805 223 3.,	30	acc. to formula $L = n_B \cdot T_2 - 4$ up to 133/3986 max.
	P	R1805 222 31,	R1805 222 3.,		
	SP	R1805 221 31,	R1805 221 3.,		
	UP	R1805 229 31,	R1805 229 3.,		
35	H	R1805 323 31,	R1805 323 3.,	40	acc. to formula $L = n_B \cdot T_2 - 4$ up to 100/3996 max.
	P	R1805 322 31,	R1805 322 3.,		
	SP	R1805 321 31,	R1805 321 3.,		
	UP	R1805 329 31,	R1805 329 3.,		
45	H	R1805 423 31,	R1805 423 3.,	52.5	acc. to formula $L = n_B \cdot T_2 - 4$ up to 76/3986 max.
	P	R1805 422 31,	R1805 422 3.,		
	SP	R1805 421 31,	R1805 421 3.,		
	UP	R1805 429 31,	R1805 429 3.,		
55	H	R1805 523 31,	R1805 523 3.,	60	acc. to formula $L = n_B \cdot T_2 - 4$ up to 66/3956 max.
	P	R1805 522 31,	R1805 522 3.,		
	SP	R1805 521 31,	R1805 521 3.,		
	UP	R1805 529 31,	R1805 529 3.,		
65	H	R1805 623 31,	R1805 623 3.,	75	acc. to formula $L = n_B \cdot T_2 - 4$ up to 53/3971 max.
	P	R1805 622 31,	R1805 622 3.,		
	SP	R1805 621 31,	R1805 621 3.,		
	UP	R1805 629 31,	R1805 629 3.,		

Standard guide rails R1805 .2. ..

Guide rail with tapped holes at the end faces, without cover strip.
(The cover strip and strip clamps or protective caps must be ordered separately.)

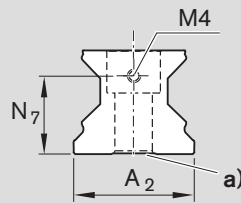

a) Due to manufacturing reasons, guide rails in accuracy class H may not have a slot on the base.

For mounting on mineral cast beds, guide rails with a flat base (without slot) are available in accuracy classes P and SP on request.

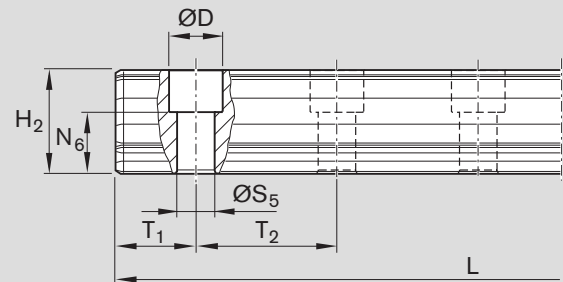

Size	Dimensions (mm)										Weight kg/m
	A ₂	D	H ₂ ¹⁾	L _{max} ²⁾	N ₆ ^{±0.5}	N ₇	S ₅	T _{1 min} ³⁾	T _{1S} ⁴⁾	T ₂	
25	23	11	23.40	4000	14.3	15.0	7	13	13.00	30.0	3.1
35	34	15	30.80	4000	19.4	22.0	9	16	18.00	40.0	6.3
45	45	20	38.80	4000	22.4	30.0	14	18	24.25	52.5	10.3
55	53	24	47.55	4000	28.7	30.0	16	20	28.00	60.0	13.1
65	63	26	57.85	4000	36.5	40.0	18	21	35.50	75.0	17.4

1) Dimension H₂ without cover strip

2) For sizes 35 to 65 in accuracy class H and P, one-piece guide rails up to approx. 6000 mm in length can be supplied in special cases.
For availability of accuracy class SP, please consult us.

3) Rails with T₁ smaller than T_{1 min} have no tapped hole at the end face for securing the strip! Secure the cover strip! Please refer to the mounting instructions.

4) Preferred dimension T_{1S} with tolerances +0.5/-1.0

Standard Guide Rails, Steel version

Guide Rails with Plastic Mounting Hole Plugs

Guide rail R1805 .5. ..

For mounting from above,
with plastic mounting hole plugs
(included)

Notes

Plastic mounting hole plugs are also available as accessories.

For details on how to mount the plastic plugs, see "Mounting Instructions for Roller Rail Systems".

For corrosion-resistant guide rails, Resist CR, matte silver hard chrome plated, see section on "Standard Guide Rails, Resist CR", part numbers R1845 .0. ..

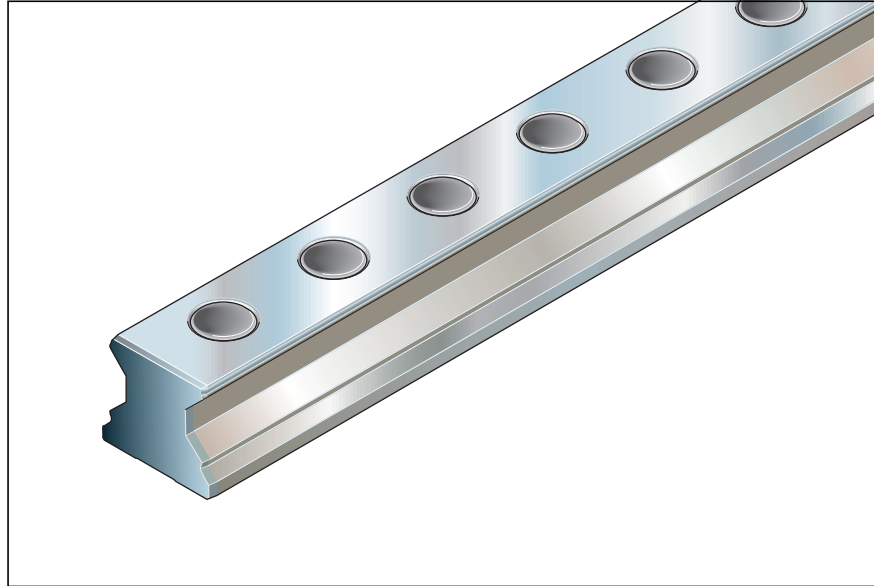

Size	Accuracy class	Guide rail		Spacing T_2 mm	Recommended rail lengths Number of holes n_B / Rail length L (mm)
		One-piece Part number, Rail length L (mm)	Composite Part number and number of sections, Rail length L (mm)		
25	H	R1805 253 31,	R1805 253 3.,	30	acc. to formula $L = n_B \cdot T_2 - 4$ up to 133/3986 max.
	P	R1805 252 31,	R1805 252 3.,		
	SP	R1805 251 31,	R1805 251 3.,		
	UP	R1805 259 31,	R1805 259 3.,		
35	H	R1805 353 31,	R1805 353 3.,	40	acc. to formula $L = n_B \cdot T_2 - 4$ up to 100/3996 max.
	P	R1805 352 31,	R1805 352 3.,		
	SP	R1805 351 31,	R1805 351 3.,		
	UP	R1805 359 31,	R1805 359 3.,		
45	H	R1805 453 31,	R1805 453 3.,	52.5	acc. to formula $L = n_B \cdot T_2 - 4$ up to 76/3986 max.
	P	R1805 452 31,	R1805 452 3.,		
	SP	R1805 451 31,	R1805 451 3.,		
	UP	R1805 459 31,	R1805 459 3.,		
55	H	R1805 553 31,	R1805 553 3.,	60	acc. to formula $L = n_B \cdot T_2 - 4$ up to 66/3956 max.
	P	R1805 552 31,	R1805 552 3.,		
	SP	R1805 551 31,	R1805 551 3.,		
	UP	R1805 559 31,	R1805 559 3.,		
65	H	R1805 653 31,	R1805 653 3.,	75	acc. to formula $L = n_B \cdot T_2 - 4$ up to 53/3971 max.
	P	R1805 652 31,	R1805 652 3.,		
	SP	R1805 651 31,	R1805 651 3.,		
	UP	R1805 659 31,	R1805 659 3.,		

Standard guide rails R1805 .5. ..

Plastic mounting hole plugs are supplied with the guide rails and are also available as accessories. For details on how to mount the plastic plugs, see "Mounting Instructions for Roller Rail Systems".

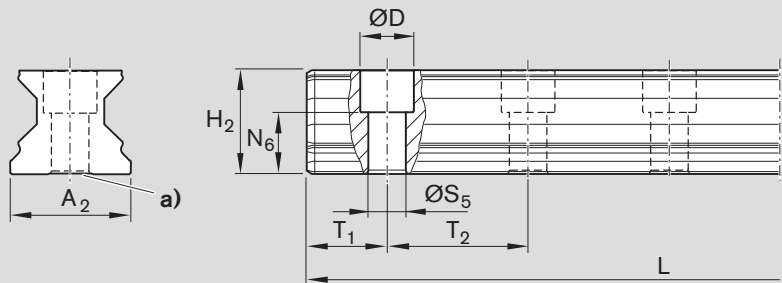

- a) Due to manufacturing reasons, guide rails in accuracy class H may not have a slot on the base.
For mounting on mineral cast beds, guide rails with a flat base (without slot) are available in accuracy classes P and SP on request.

Size	Dimensions (mm)									Weight kg/m
	A_2	D	H_2	$L_{max}^{1)}$	$N_6^{\pm 0.5}$	S_5	$T_{1\ min}$	$T_{1S}^{2)}$	T_2	
25	23	11	23.40	4000	14.3	7	10	13.00	30.0	3.1
35	34	15	30.80	4000	19.4	9	12	18.00	40.0	6.3
45	45	20	38.80	4000	22.4	14	16	24.25	52.5	10.3
55	53	24	47.55	4000	28.7	16	18	28.00	60.0	13.1
65	63	26	57.85	4000	36.5	18	20	35.50	75.0	17.4

- 1) For sizes 35 to 65 in accuracy class H and P, one-piece guide rails up to approx. 6000 mm in length can be supplied in special cases.
For availability of accuracy class SP, please consult us.
- 2) Preferred dimension T_{1S} with tolerances $+0.5/-1.0$

Standard Guide Rails, Steel version

Guide Rails for Steel Mounting Hole Plugs

Guide rail R1806 .5. ..

For mounting from above,
for steel mounting hole plugs
(not included)

Notes

Steel mounting hole plugs and the mounting tool must be ordered separately. For part numbers, see the following page.

Please follow the mounting instructions for Roller Rail Systems and for steel mounting hole plugs.

For corrosion-resistant guide rails, Resist CR, matte silver hard chrome plated, see section on "Standard Guide Rails, Resist CR", part numbers R1846 .0. ..

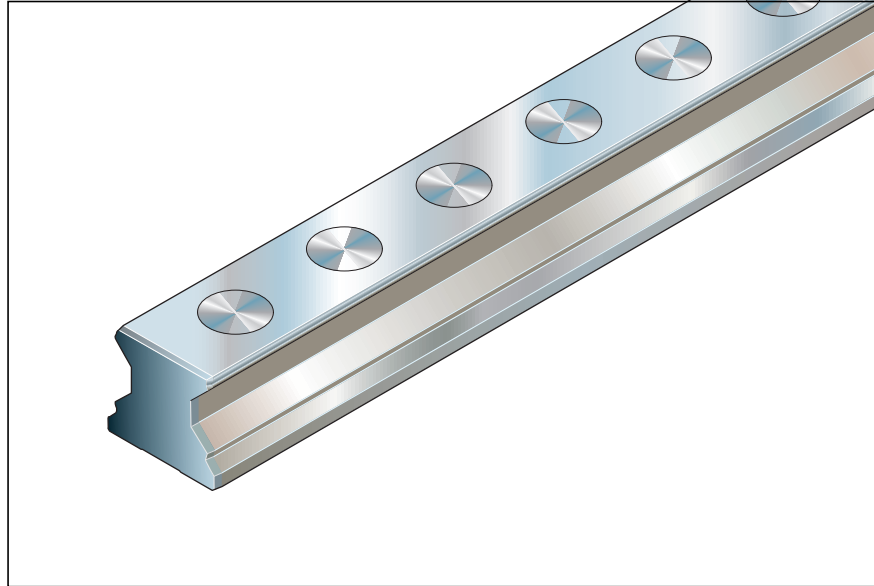

Size	Accuracy class	Guide rail		Spacing T_2 mm	Recommended rail lengths Number of holes n_B / Rail length L (mm)
		One-piece Part number, Rail length L (mm)	Composite Part number and number of sections, Rail length L (mm)		
25	H	R1806 253 31,	R1806 253 3.,	30	acc. to formula $L = n_B \cdot T_2 - 4$ up to 133/3986 max.
	P	R1806 252 31,	R1806 252 3.,		
	SP	R1806 251 31,	R1806 251 3.,		
35	H	R1806 353 31,	R1806 353 3.,	40	acc. to formula $L = n_B \cdot T_2 - 4$ up to 100/3996 max.
	P	R1806 352 31,	R1806 352 3.,		
	SP	R1806 351 31,	R1806 351 3.,		
45	H	R1806 453 31,	R1806 453 3.,	52.5	acc. to formula $L = n_B \cdot T_2 - 4$ up to 76/3986 max.
	P	R1806 452 31,	R1806 452 3.,		
	SP	R1806 451 31,	R1806 451 3.,		
55	H	R1806 553 31,	R1806 553 3.,	60	acc. to formula $L = n_B \cdot T_2 - 4$ up to 66/3956 max.
	P	R1806 552 31,	R1806 552 3.,		
	SP	R1806 551 31,	R1806 551 3.,		
65	H	R1806 653 31,	R1806 653 3.,	75	acc. to formula $L = n_B \cdot T_2 - 4$ up to 53/3971 max.
	P	R1806 652 31,	R1806 652 3.,		
	SP	R1806 651 31,	R1806 651 3.,		

Standard guide rails R1806 .5. ..

Steel mounting hole plugs are not supplied with the guide rails. When ordering them, do not forget to order the mounting tool! For details on how to mount the steel plugs, see "Mounting Instructions for Roller Rail Systems".

a) Due to manufacturing reasons, guide rails in accuracy class H may not have a slot on the base.
For mounting on mineral cast beds, guide rails with a flat base (without slot) are available in accuracy classes P and SP on request.

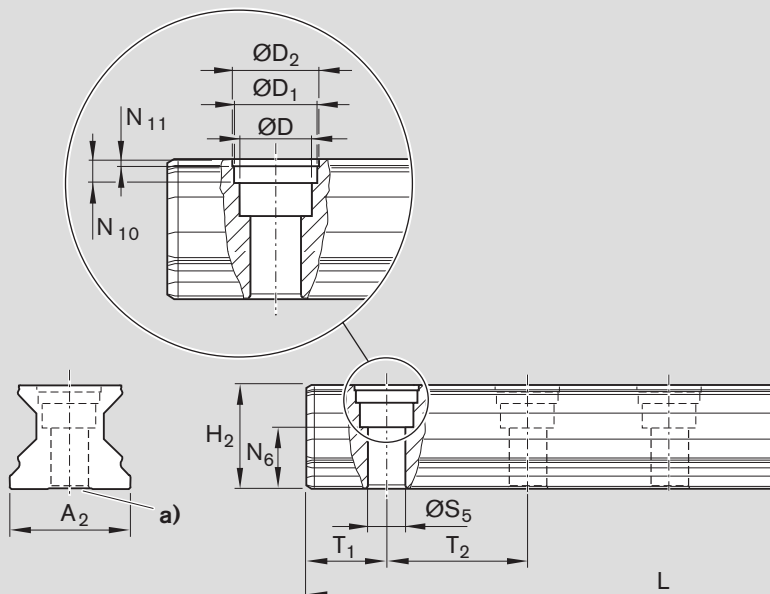

Size	Dimensions (mm)														Weight kg/m
	A_2	D	D_1	D_2	H_2	$L_{max}^{1)}$	$N_6^{\pm 0.5}$	N_{10}	N_{11}	S_5	T_{1min}	$T_{1S}^{2)}$	T_2		
25	23	11	12.55	13	23.40	4000	14.3	3.7	0.90	7	10	13.00	30.0	3.1	
35	34	15	17.55	18	30.80	4000	19.4	3.6	0.90	9	12	18.00	40.0	6.3	
45	45	20	22.55	23	38.80	4000	22.4	8.0	1.45	14	16	24.25	52.5	10.3	
55	53	24	27.55	28	47.55	4000	28.7	8.0	1.45	16	18	28.00	60.0	13.1	
65	63	26	29.55	30	57.85	4000	36.5	8.0	1.45	18	20	35.50	75.0	17.4	

- 1) For sizes 35 to 65 in accuracy class H and P, one-piece guide rails up to approx. 6000 mm in length can be supplied in special cases. For availability of accuracy class SP, please consult us.
- 2) Preferred dimension T_{1S} with tolerances $+0.5/-1.0$

Steel mounting hole plugs

Must be ordered separately!

Size	Single plug made of machining steel Part numbers	Weight (g)
25	R1606 200 75	2
35	R1606 300 75	3
45	R1606 400 75	6
55	R1606 500 75	8
65	R1606 600 75	9

Mounting tool for steel mounting hole plugs

Order this tool along with the plugs!

Two-piece mounting tool for fitting plugs to a screwed down guide rail.

Size	Part numbers	Weight (kg)
25	R1619 210 20 ¹⁾	0.37
35	R1619 310 30	0.57
45	R1619 410 30	0.85
55	R1619 510 30	1.50
65	R1619 610 30	1.85

- 1) One-piece; two-piece on request

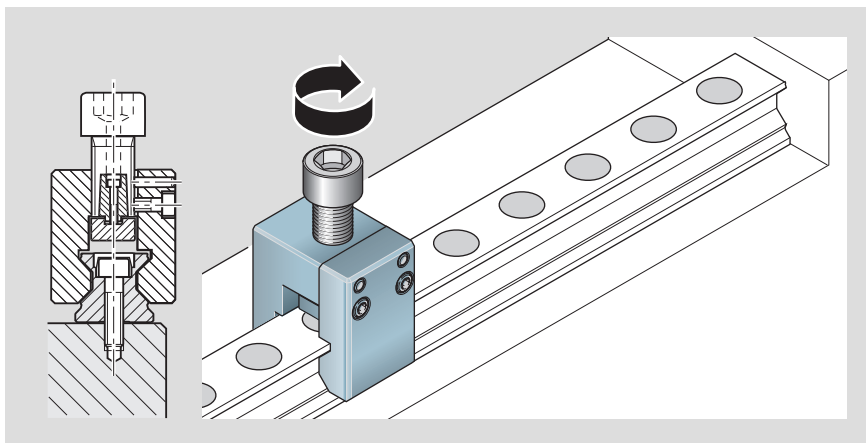

Standard Guide Rails, Steel version

Guide Rails for Mounting From Below

Guide rail R1807 .0. ..

for mounting from below,
top surface hardened

Note

For corrosion-resistant guide rails,
Resist CR, matte silver hard chrome
plated, see section on "Standard
Guide Rails, Resist CR", part numbers
R1847 .0. ..

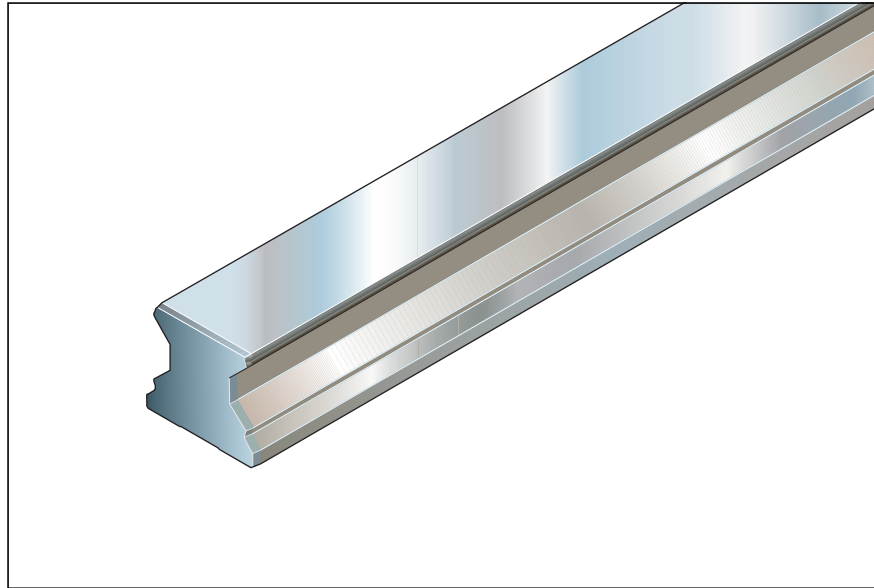

Size	Accuracy class	Guide rail		Spacing T_2 mm	Recommended rail lengths Number of holes n_B / Rail length L (mm)
		One-piece Part number, Rail length L (mm)	Composite Part number and number of sections, Rail length L (mm)		
25	H	R1807 203 31,	R1807 203 3.,	30	acc. to formula $L = n_B \cdot T_2 - 4$ up to 133/3986 max.
	P	R1807 202 31,	R1807 202 3.,		
	SP	R1807 201 31,	R1807 201 3.,		
	UP	R1807 209 31,	R1807 209 3.,		
35	H	R1807 303 31,	R1807 303 3.,	40	acc. to formula $L = n_B \cdot T_2 - 4$ up to 100/3996 max.
	P	R1807 302 31,	R1807 302 3.,		
	SP	R1807 301 31,	R1807 301 3.,		
	UP	R1807 309 31,	R1807 309 3.,		
45	H	R1807 403 31,	R1807 403 3.,	52.5	acc. to formula $L = n_B \cdot T_2 - 4$ up to 76/3986 max.
	P	R1807 402 31,	R1807 402 3.,		
	SP	R1807 401 31,	R1807 401 3.,		
	UP	R1807 409 31,	R1807 409 3.,		
55	H	R1807 503 31,	R1807 503 3.,	60	acc. to formula $L = n_B \cdot T_2 - 4$ up to 66/3956 max.
	P	R1807 502 31,	R1807 502 3.,		
	SP	R1807 501 31,	R1807 501 3.,		
	UP	R1807 509 31,	R1807 509 3.,		
65	H	R1807 603 31,	R1807 603 3.,	75	acc. to formula $L = n_B \cdot T_2 - 4$ up to 53/3971 max.
	P	R1807 602 31,	R1807 602 3.,		
	SP	R1807 601 31,	R1807 601 3.,		
	UP	R1807 609 31,	R1807 609 3.,		

Standard guide rails R1807 .0. ..

Guide rails for mounting from below!

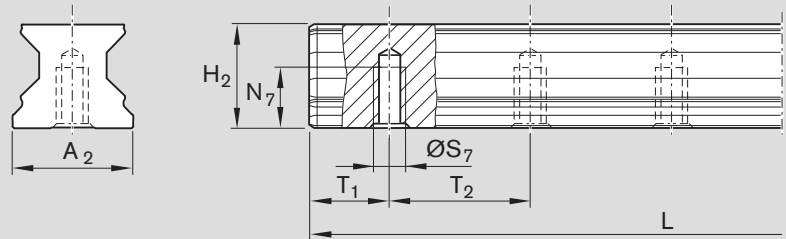

Size	Dimensions (mm)									Weight kg/m
	A ₂	H ₂	L _{max}	N ₇ ^{±0.5}	S ₇	T _{1 min}	T _{1s} ¹⁾	T ₂		
25	23	23.40	4000	12	M6	10	13.00	30.0	3.1	
35	34	30.80	4000	15	M8	12	18.00	40.0	6.3	
45	45	38.80	4000	19	M12	16	24.25	52.5	10.3	
55	53	47.55	4000	22	M14	18	28.00	60.0	13.1	
65	63	57.85	4000	25	M16	20	35.50	75.0	17.4	

1) Preferred dimension T_{1s} with tolerances +0.5/-1.0

Standard Guide Rails, Resist CR version

Guide Rails

General notes on guide rails in Resist CR

For part numbers, see the following pages.
For recommended rail lengths, dimensions and weights, please refer to the corresponding standard guide rails, steel version.

Corrosion-resistant coating Resist CR: matte silver hard chrome plated

Guide rails with corrosion-resistant coating Resist CR, matte silver hard chrome plated, replace the guide rails with zinc-iron coating.

One-piece guide rails with coated or uncoated end faces

One-piece Resist CR guide rails are available in two versions:

- End faces **uncoated** (on request in some cases), identified by part numbers:
 - R18.. ... 31 or
 - R18.. ... 61
- End faces, chamfers and end-face threads coated, identified by part numbers:
 - R18.. ... 41 or
 - R18.. ... 71

In composite Resist CR guide rails the joint faces are coated as well as the end faces.

Different tolerances for Resist CR coating

Caution!

For runner blocks and guide rails in Resist CR, matte silver hard chrome plated, different tolerances apply for the dimensions H and A₃ (see "Accuracy classes and their tolerances").

Higher preload for combinations of hard chrome plated runner blocks with hard chrome plated guide rails

When hard chrome plated runner blocks with preload $C2 = 8\% C$ are combined with hard chrome plated guide rails, the preload increases to approx. 10% C.

Standard Guide Rails, Resist CR version

Guide Rails with Cover Strip

Guide rail R1845 .6. ..

For mounting from above, with cover strip and screw-down protective caps

Size	Accuracy class ¹⁾	Guide rail One-piece Part number, Rail length L (mm)	Composite Part number and number of sections, Rail length L (mm)
25	H	R1845 263 31,	–
		R1845 263 41,	R1845 263 4.,
35	H	R1845 363 61,	–
		R1845 363 71,	R1845 363 7.,
45	H	R1845 463 61,	–
		R1845 463 71,	R1845 463 7.,
55	H	R1845 563 61,	–
		R1845 563 71,	R1845 563 7.,
65	H	R1845 663 61,	–
		R1845 663 71,	R1845 663 7.,

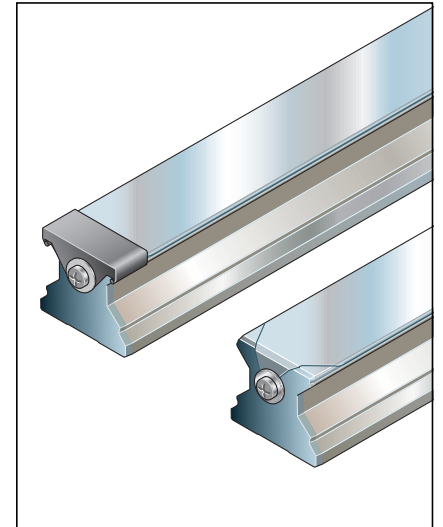

Guide rail R1845 .3. ..

For mounting from above, with cover strip and strip clamps

Size	Accuracy class ¹⁾	Guide rail One-piece Part number, Rail length L (mm)	Composite Part number and number of sections, Rail length L (mm)
25	H	R1845 233 31,	–
		R1845 233 41,	R1845 233 4.,
35	H	R1845 333 61,	–
		R1845 333 71,	R1845 333 7.,
45	H	R1845 433 61,	–
		R1845 433 71,	R1845 433 7.,
55	H	R1845 533 61,	–
		R1845 533 71,	R1845 533 7.,
65	H	R1845 633 61,	–
		R1845 633 71,	R1845 633 7.,

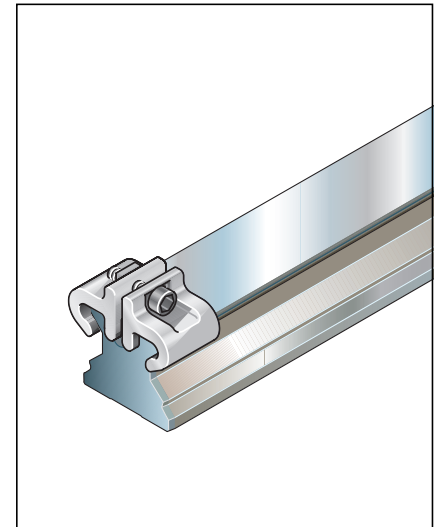

1) Accuracy classes P and SP on request

Caution!

Please read the general notes on guide rails in Resist CR!

For recommended rail lengths, dimensions and weights, as well as notes on securing the cover strip, please refer to the corresponding standard guide rails, steel version, part numbers:

- R1805 .6. .. (with protective end caps)
- R1805 .3. .. (with strip clamps)

Standard Guide Rails, Resist CR version

Guide Rails for Cover Strip

Guide rail R1845 .7. ..

For mounting from above, for cover strip (not included)

Size	Accuracy class ¹⁾	Guide rail One-piece Part number, Rail length L (mm)	Composite Part number and number of sections, Rail length L (mm)
25	H	R1845 273 31,	–
		R1845 273 41,	R1845 273 4.,
35	H	R1845 373 31,	–
		R1845 373 41,	R1845 373 4.,
45	H	R1845 473 31,	–
		R1845 473 41,	R1845 473 4.,
55	H	R1845 573 31,	–
		R1845 573 41,	R1845 573 4.,
65	H	R1845 673 31,	–
		R1845 673 41,	R1845 673 4.,

1) Accuracy classes P and SP on request

Caution!

Please read the general notes on guide rails in Resist CR!

For recommended rail lengths, dimensions and weights, please refer to the corresponding standard guide rails, steel version, part numbers R1805 .2. ..

Notes

The cover strip and strip clamps or protective caps must be ordered separately. For part numbers and dimensions see "Accessories".

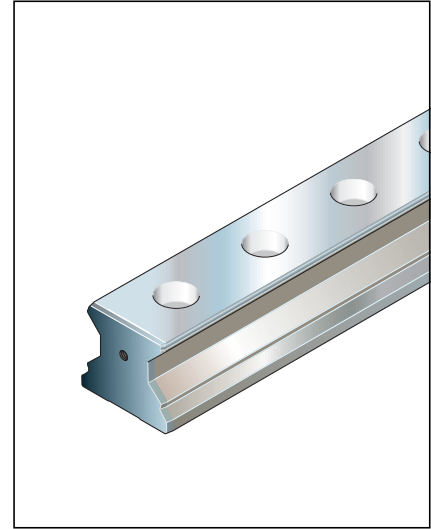

Standard Guide Rails, Resist CR version

Guide Rails with Plastic Mounting Hole Plugs

Guide rail R1845 .0. ..

For mounting from above, with plastic mounting hole plugs (included)

Size	Accuracy class ¹⁾	Guide rail	
		One-piece Part number, Rail length L (mm)	Composite Part number and number of sections, Rail length L (mm)
25	H	R1845 203 31,	–
		R1845 203 41,	R1845 203 4.,
35	H	R1845 303 31,	–
		R1845 303 41,	R1845 303 4.,
45	H	R1845 403 31,	–
		R1845 403 41,	R1845 403 4.,
55	H	R1845 503 31,	–
		R1845 503 41,	R1845 503 4.,
65	H	R1845 603 31,	–
		R1845 603 41,	R1845 603 4.,

1) Accuracy classes P and SP on request

Caution!

Please read the general notes on guide rails in Resist CR!

For recommended rail lengths, dimensions and weights, please refer to the corresponding standard guide rails, steel version, part numbers R1805 .5. ..

Notes

Plastic mounting hole plugs are also available as accessories.

For details on how to mount the plastic plugs, see "Mounting Instructions for Roller Rail Systems".

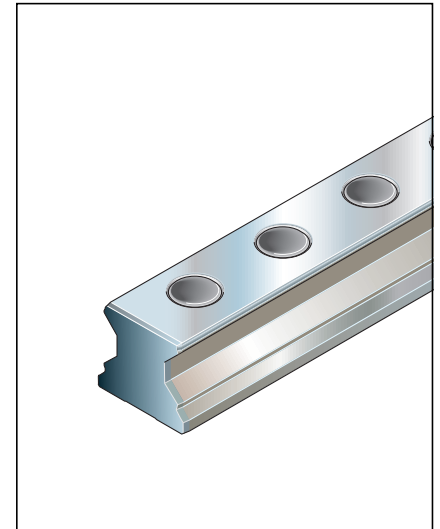

Standard Guide Rails, Resist CR version

Guide Rails for Steel Mounting Hole Plugs

Guide rail R1846 .0. ..

For mounting from above, for steel mounting hole plugs (not included)

Size	Accuracy class ¹⁾	Guide rail One-piece Part number, Rail length L (mm)	Composite Part number and number of sections, Rail length L (mm)
25	H	R1846 203 31,	–
		R1846 203 41,	R1846 203 4.,
35	H	R1846 303 31,	–
		R1846 303 41,	R1846 303 4.,
45	H	R1846 403 31,	–
		R1846 403 41,	R1846 403 4.,
55	H	R1846 503 31,	–
		R1846 503 41,	R1846 503 4.,
65	H	R1846 603 31,	–
		R1846 603 41,	R1846 603 4.,

1) Accuracy classes P and SP on request

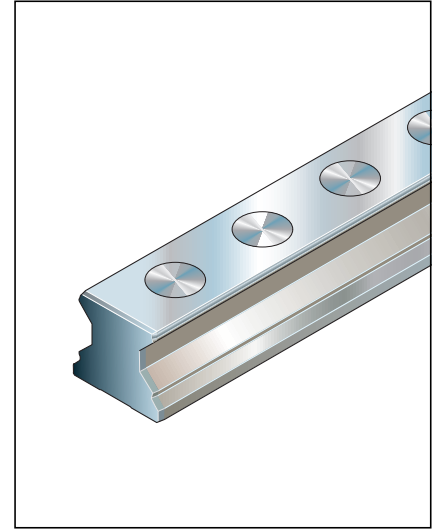

Caution!

Please read the general notes on guide rails in Resist CR!
For recommended rail lengths, dimensions and weights, please refer to the corresponding standard guide rails, steel version, part numbers R1806 .5. ..

Notes

Corrosion-resistant steel mounting hole plugs and the mounting tool must be ordered separately. See below for part numbers.
Please follow the mounting instructions for Roller Rail systems and for steel mounting hole plugs.

Corrosion-resistant steel mounting hole plugs

Must be ordered separately!

For corrosion-resistant guide rails in Resist CR, we recommend using mounting hole plugs in Resist NR II (made from corrosion-resistant steel 1.4305).

Size	Single plug, Resist NR II	
	Part numbers	Weight (g)
25	on request	on request
35		
45	R1606 400 78	6
55	R1606 500 78	8
65	R1606 600 78	9

Mounting hole plugs made from machining steel (part numbers R1606 .00 75) can, however, also be used (see "Accessories").

Mounting tool for steel mounting hole plugs

Order this tool along with the plugs!

Two-piece mounting tool for fitting plugs to a screwed down guide rail.

Size	Part numbers	Weight (kg)
25	R1619 210 20 ¹⁾	0.37
35	R1619 310 30	0.57
45	R1619 410 30	0.85
55	R1619 510 30	1.50
65	R1619 610 30	1.85

1) One-piece; two-piece on request

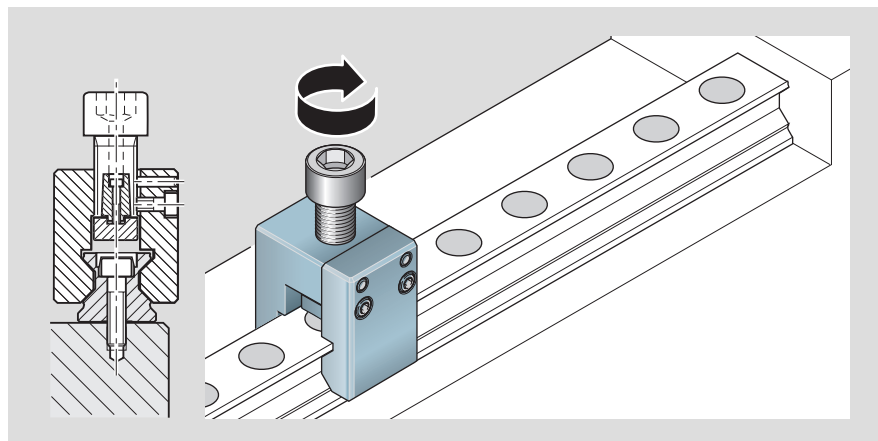

Standard Guide Rails, Resist CR version

Guide Rails for Mounting From Below

Guide rail R1847 .0. ..

For mounting from below, top surface hardened

Size	Accuracy class ¹⁾	Guide rail One-piece Part number, Rail length L (mm)	Composite Part number and number of sections, Rail length L (mm)
25	H	R1847 203 31, ²⁾	–
		R1847 203 41,	R1847 203 4.,
35	H	R1847 303 31,	–
		R1847 303 41,	R1847 303 4.,
45	H	R1847 403 31, ²⁾	–
		R1847 403 41,	R1847 403 4.,
55	H	R1847 503 31, ²⁾	–
		R1847 503 41,	R1847 503 4.,
65	H	R1847 603 31, ²⁾	–
		R1847 603 41,	R1847 603 4.,

1) Accuracy classes P and SP on request

2) One-piece guide rails with **uncoated** end faces on request (size 35 available)

Caution!

Please read the general notes on guide rails in Resist CR!

For recommended rail lengths, dimensions and weights, please refer to the corresponding standard guide rails, steel version, part numbers R1807 .0. ..

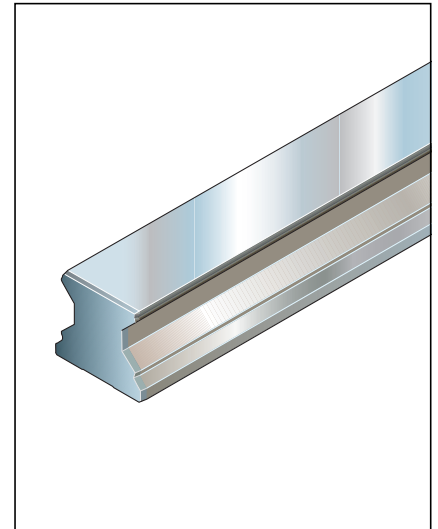

V-Guide Rails

Product Description

Outstanding features

Thanks to their mounting style, V-Guide Rails offer the following advantages:

- Optimally smooth runner block travel, since there are no mounting holes in the guide rail
- Improved straightness through uninterrupted guide rail profile
- Smooth rail surface for optimal sealing action
- Cost-saving – only one row of holes necessary for mounting and alignment

Thanks to Rexroth's proven policy of interchangeability, the entire range of runner blocks and accessories can be used with these rails.

Further highlights

- Number of pressure pieces can be varied to match loads.
- No need for mounting hole plugs or covers
- Mounting base can be machined using standard profile milling tools.

Load-dependent fastening¹⁾

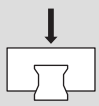
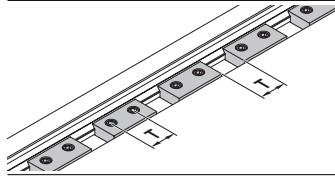
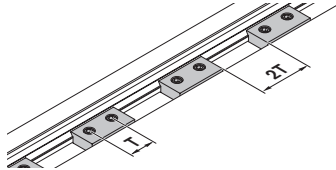
Arrangement of pressure pieces	Load capacities of V-Guide Rails (%)		
	Down load C_0	Lift-off load F_{max}	Side load F_{max}
	100	100	100
	100	70 ²⁾	70 ²⁾
	100	30 ²⁾	50 ²⁾

1) See "Mounting Instructions"

2) Guide values

Standard Roller Runner Block with V-Guide Rail (fastened using pressure pieces)

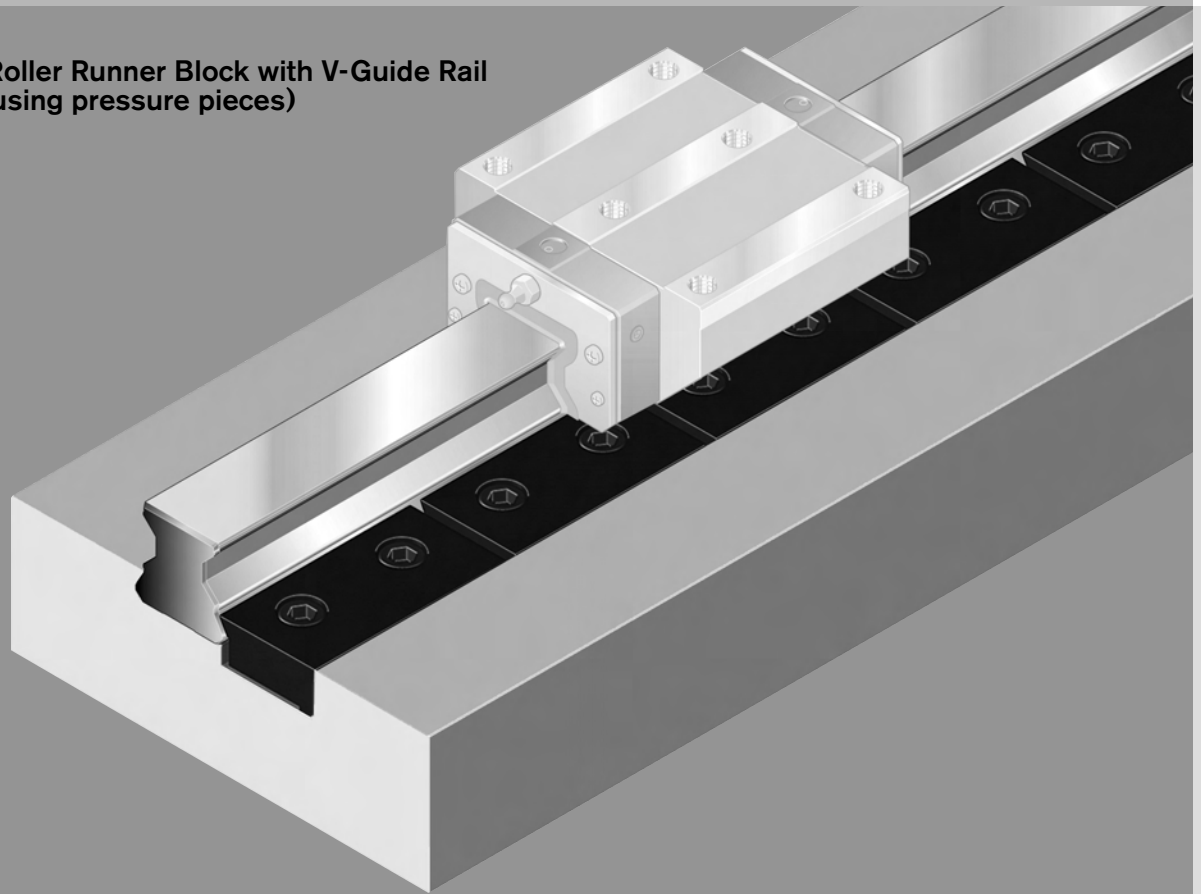

Comparison of mounting styles Roller rail system with standard guide rail

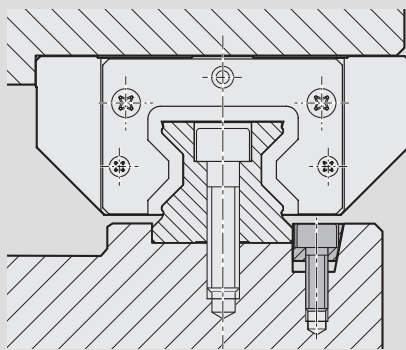

Mounting of standard guide rail

The standard guide rail is pressed against the reference edge using clamping strips or wedge profiles to align it. The rail is screwed into place from above or below. Mounting holes in the standard guide rail are closed with a cover strip or plugs. Two rows of holes per rail are needed in the machine bed.

Roller rail system with V-guide rail

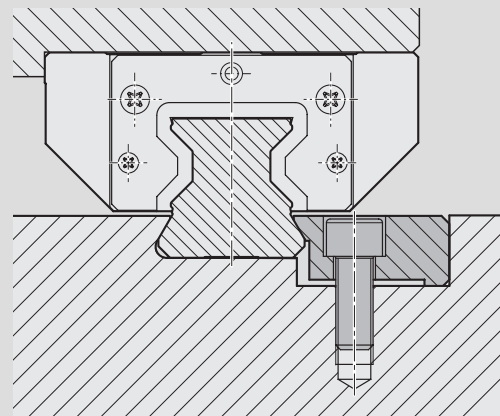

Mounting of V-Guide Rail

The V-guide rail is installed using pressure pieces to push it up against an inclined reference edge, align it and fix it in place. The number of pressure pieces can be varied to match loads. The V-guide rail has no mounting holes. If desired, the pressure pieces can be covered. Only one row of holes per rail is needed in the machine bed.

V-Guide Rails

V-Guide Rails without Mounting Holes

V-guide rail R1808 .1. 3.

Without mounting holes.
Mounting with pressure pieces.

Note

Composite guide rails also available.
The joints must be mounted with a central pressure piece.

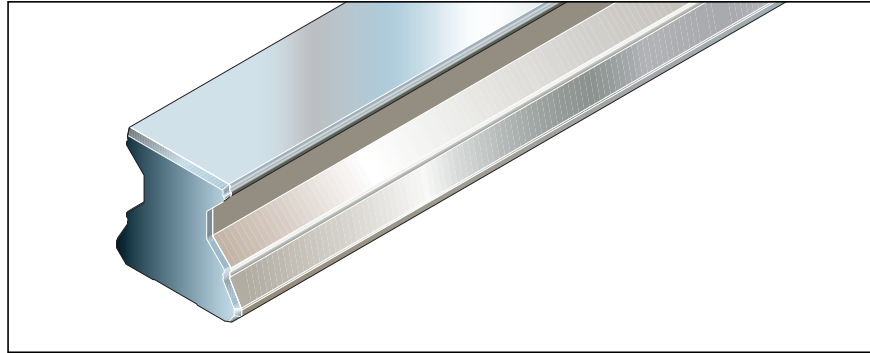

Size ¹⁾	Accuracy class	Guide rail		Rail lengths One-piece L_{\max} ²⁾ mm
		One-piece Part number, Rail length L (mm)	Composite Part number and number of sections, Rail length L (mm)	
35	H	R1808 313 31, ...	R1808 313 3., ...	4000
	P	R1808 312 31, ...	R1808 312 3., ...	
	SP	R1808 311 31, ...	R1808 311 3., ...	
45	H	R1808 413 31, ...	R1808 413 3., ...	4000
	P	R1808 412 31, ...	R1808 412 3., ...	
	SP	R1808 411 31, ...	R1808 411 3., ...	
55	H	R1808 513 31, ...	R1808 513 3., ...	4000
	P	R1808 512 31, ...	R1808 512 3., ...	
	SP	R1808 511 31, ...	R1808 511 3., ...	

1) Size 65 in preparation

2) Freely selectable length

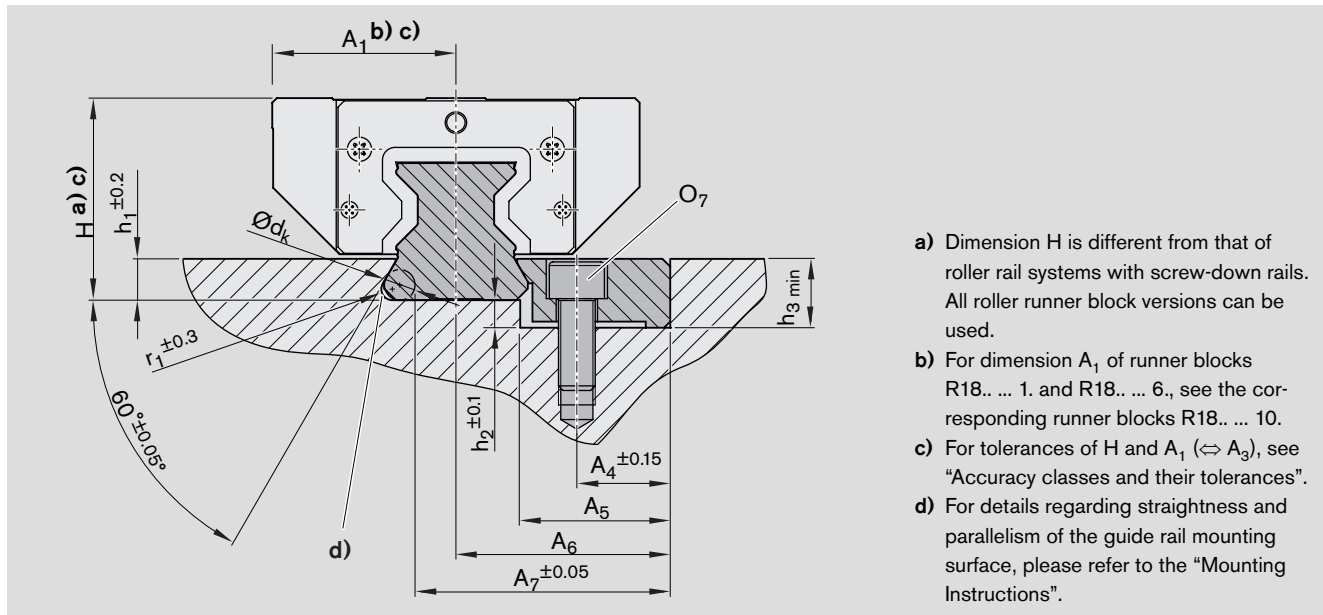

Size ¹⁾	Dimensions (mm)												Weight kg/m
	A_4	A_5	A_6	A_7	d_k	$H^2)$	$H^3)$	h_1	h_2	h_3	O_7	r_1	
35	21.5	33	50	57.093	10	53	60	10.5	4.3	9	M8 x 20	R2.6	7.8
45	30.5	49	70	83.346	10	66	76	13.5	9.0	12	M12 x 30	R3.6	12.5
55	38.0	60	85	102.652	10	76	86	15.0	10.0	14	M14 x 35	R3.8	17.6

1) Size 65 in preparation

2) Height H of runner blocks in standard height

3) Height H of high runner blocks

V-Guide Rails

Pressure Pieces for V-Guide Rails

Pressure pieces

For mounting of V-guide rails
R1808 .1. 3.

Note

The number of pressure pieces can be varied to match loads. For the arrangement of pressure pieces, see "Load depending fastening".

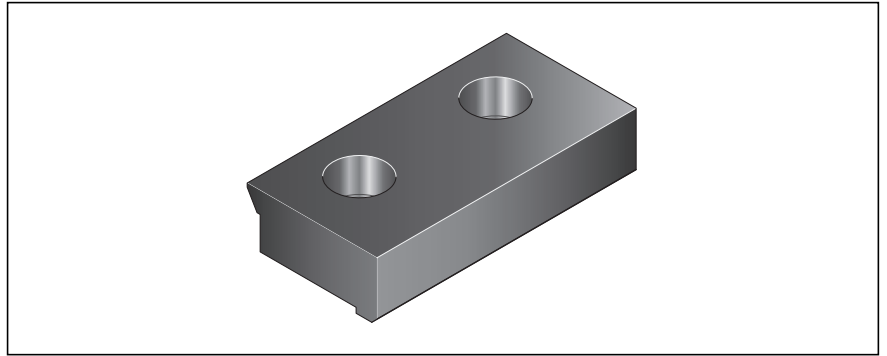

Size ¹⁾	Part numbers
35	R1810 390 65
45	R1810 490 65
55	R1810 590 65

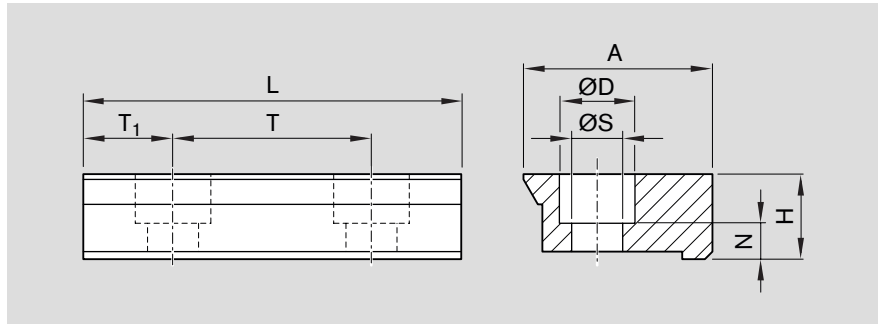

Size ¹⁾	Dimensions (mm)								Weight kg
	A	D	H	L	N	S	T	T ₁	
35	34.4	15	14.8	75	6.3	9	40.0	17.50	0.25
45	50.0	20	22.5	100	9.5	14	52.5	23.75	0.70
55	61.5	24	25.0	115	10.0	16	60.0	27.50	1.10

1) Size 65 in preparation

Suggestion for covering the pressure pieces

Notes

If desired, the pressure pieces can be covered. Take note of the dimensions given in the table.

Size ¹⁾	t _{max.} mm
35	1.2
45	1.2
55	2.5

1) Size 65 in preparation

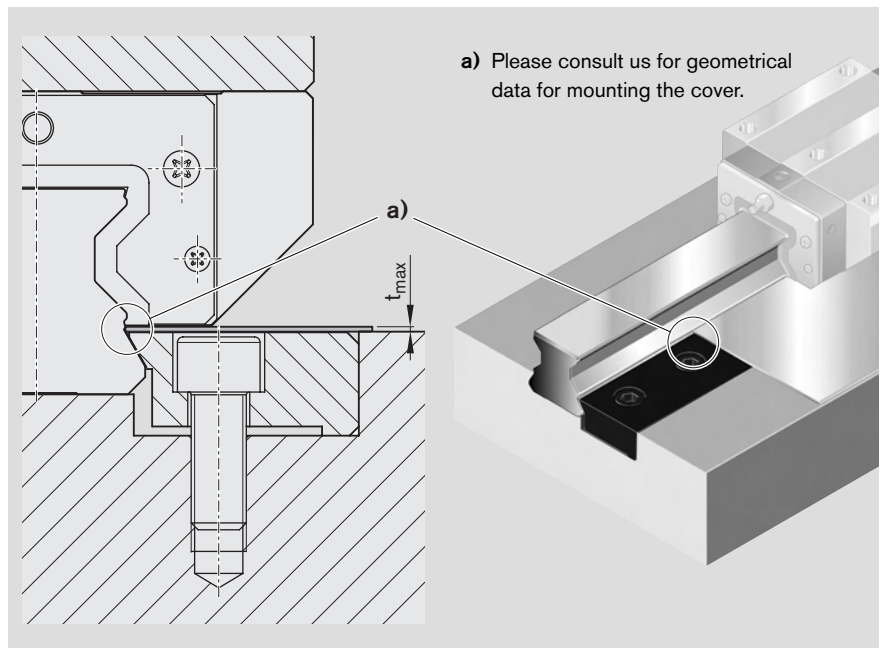

Wide Roller Rail Systems

Product Description

Outstanding features

- Wide runner blocks for applications with high moment loads and enhanced rigidity
- Improved travel characteristics
- Four reference edges on runner block for precise alignment in machine structure
- Very high torque capacity
- Very high torsional moment and torsional rigidity
- Improved rigidity under lift-off and side loading conditions through four additional mounting screw holes at the center of the runner block
- Mounting of attachments to runner block from above or below

Further highlights

- Lube ports on all sides for maximum ease of maintenance
- Novel lube duct design minimizes lubricant consumption.
- Runner blocks made from antifriction bearing steel, with hardened and ground raceways (guide rails also with hardened raceways and ground on all sides)
- Smooth running thanks to optimized roller recirculation and guidance
- Optimized entry-section geometry and high number of rollers per track minimizes variation in elastic deflection.
- Aluminum end caps
- End seals integrated as standard for better sealing of all running tracks and to protect plastic parts

Options

- Corrosion-resistant wide runner blocks and guide rails in Resist CR, matte silver hard chrome plated, available in accuracy class H (preload C2)

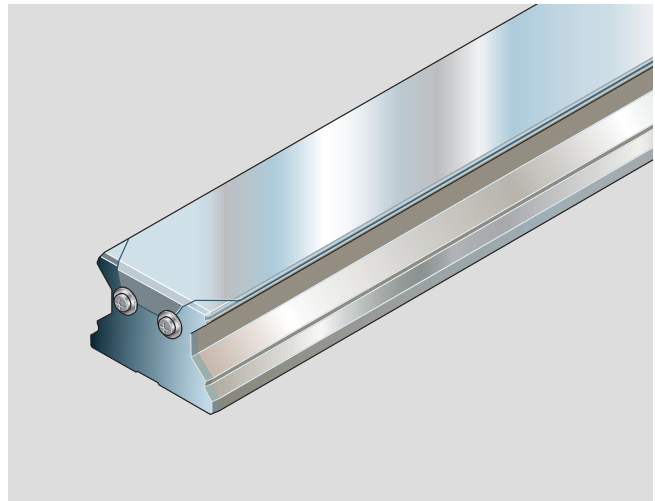

Proven cover strip for guide rail mounting holes

- A **single** cover for all holes – saves time and money
- Stainless spring steel to EN 10088
- Easy to fit – simply clip on and secure

Wide Roller Rail System

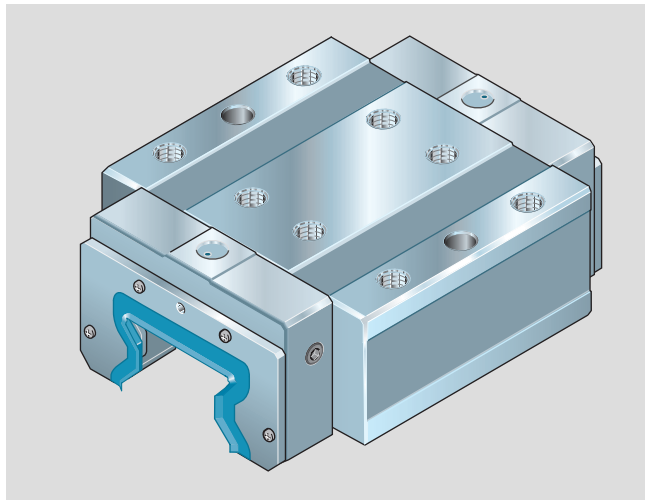
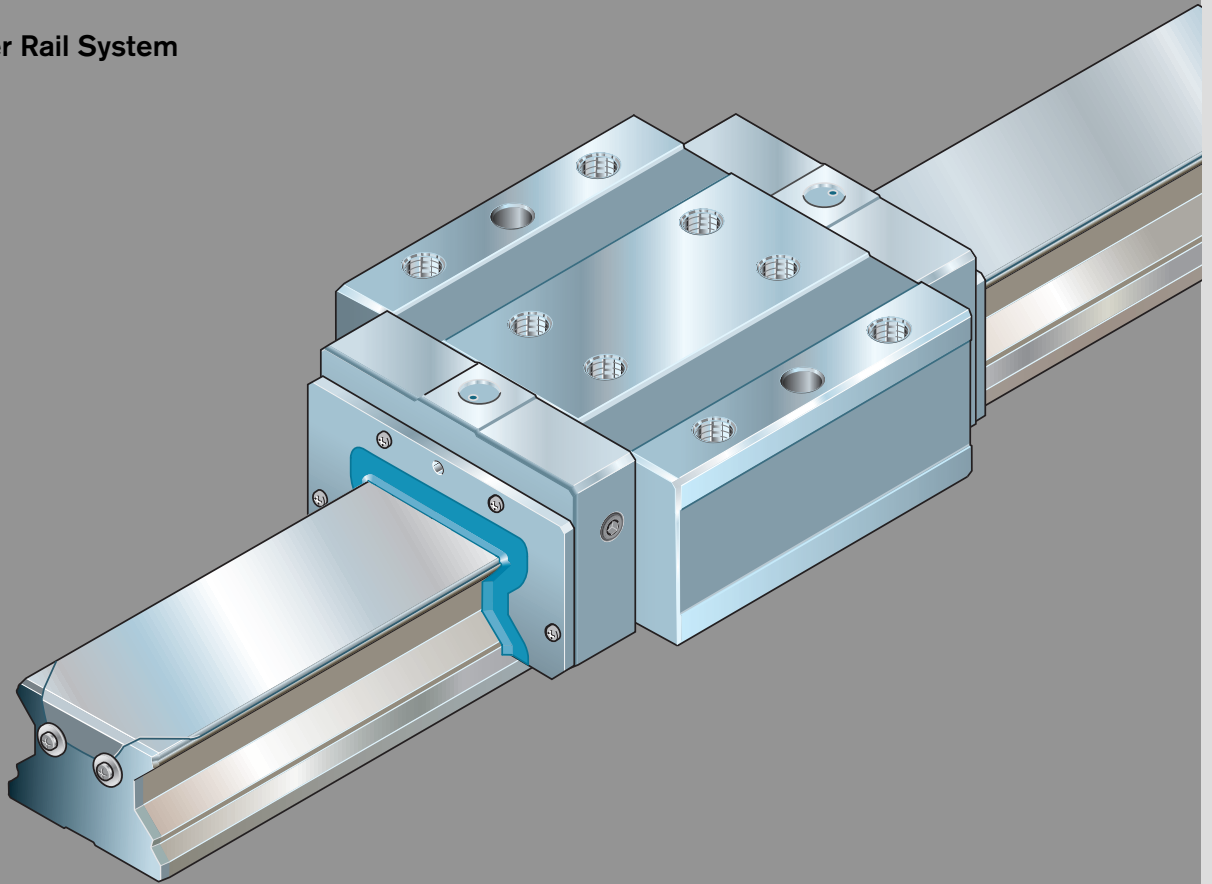

Runner block wide, long, standard height BLS R1872

- Aluminum end caps
- End seals integrated as standard for better sealing of all running tracks and to protect plastic parts

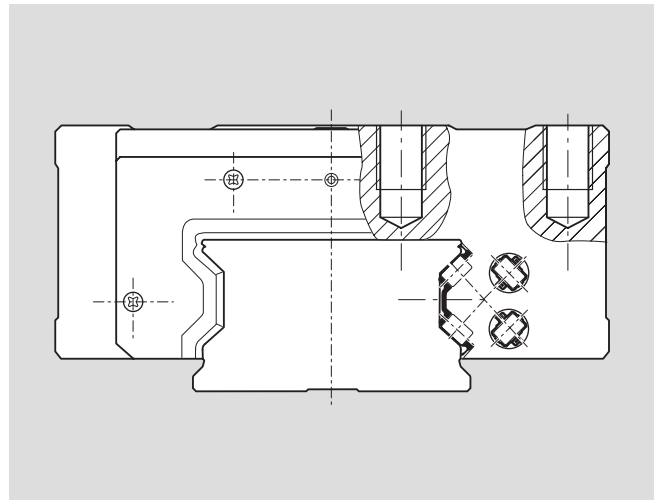

Optimal roller guidance design

- Smooth running thanks to optimized roller recirculation and guidance

Wide Roller Rail Systems

Rigidity

Rigidity of the roller rail system at preload C2

Wide runner block BLS R1872

Sizes 55/85 and 65/100

----- calculated values

Runner block mounted using 8 screws and the upper reference edges only

- All screws of strength class 12.9

1. Down load

2. Lift-off load

3. Side load

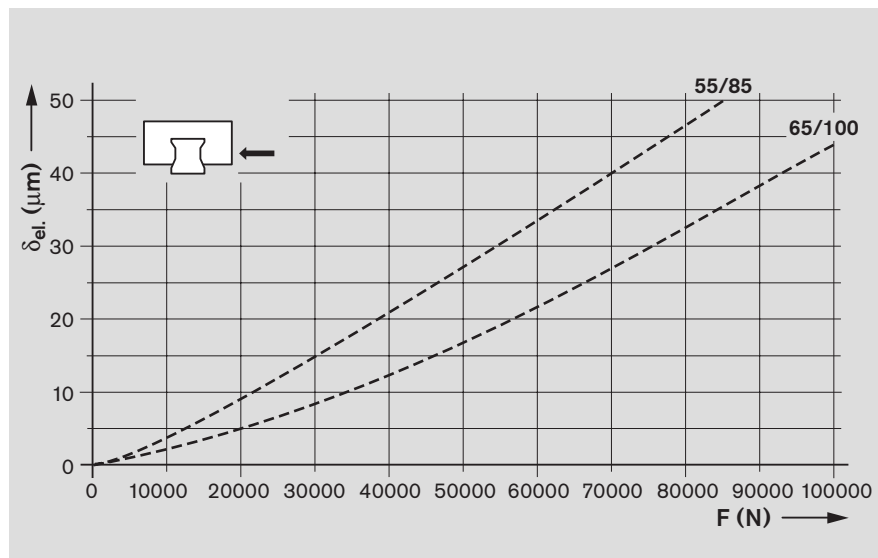
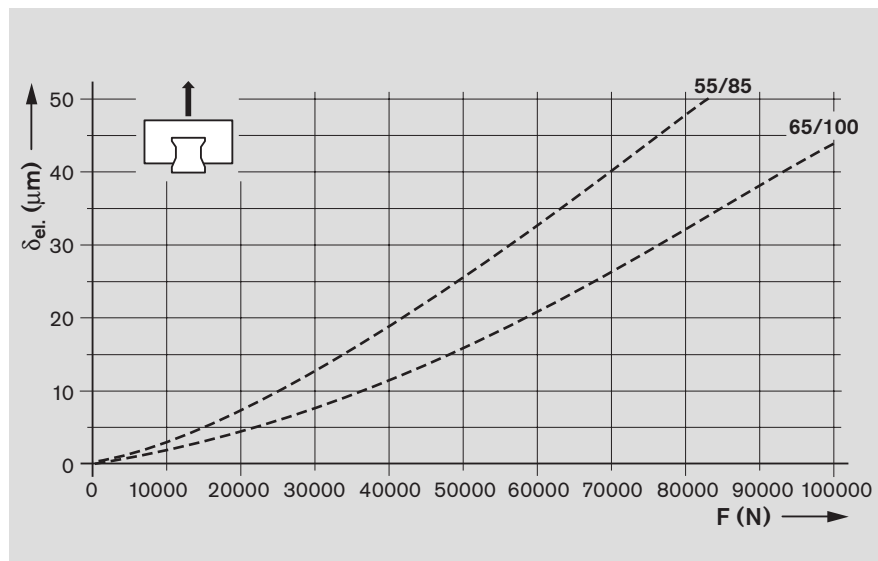
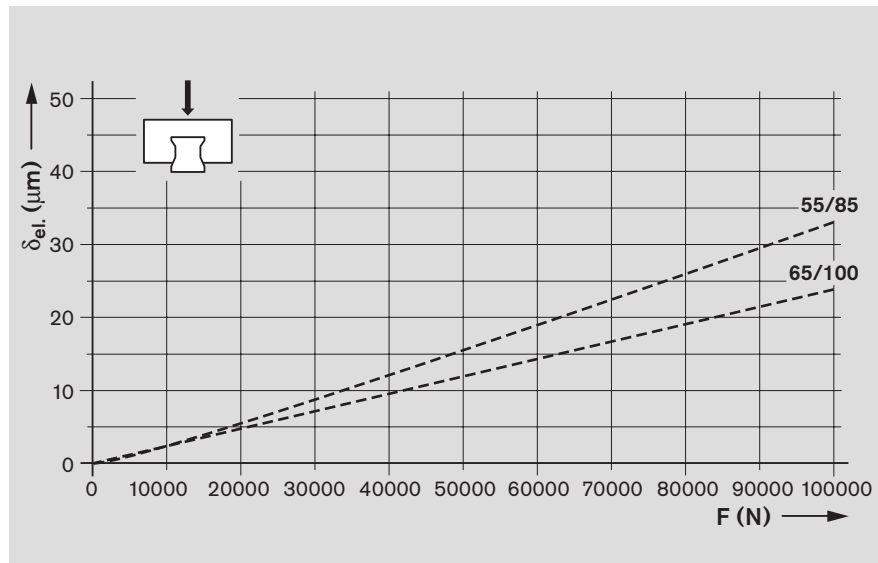

Preload class
C2 = preload 8% C

Key to graph

δ_{el.} = elastic deflection (μm)
F = load (N)

Rigidity of the roller rail system at preload C2

Wide runner block BLS R1872

Sizes 55/85 and 65/100

----- calculated values

Runner block mounted using 8 screws and all 4 reference edges (top and bottom)

- All screws of strength class 12.9

1. Down load

2. Lift-off load

3. Side load

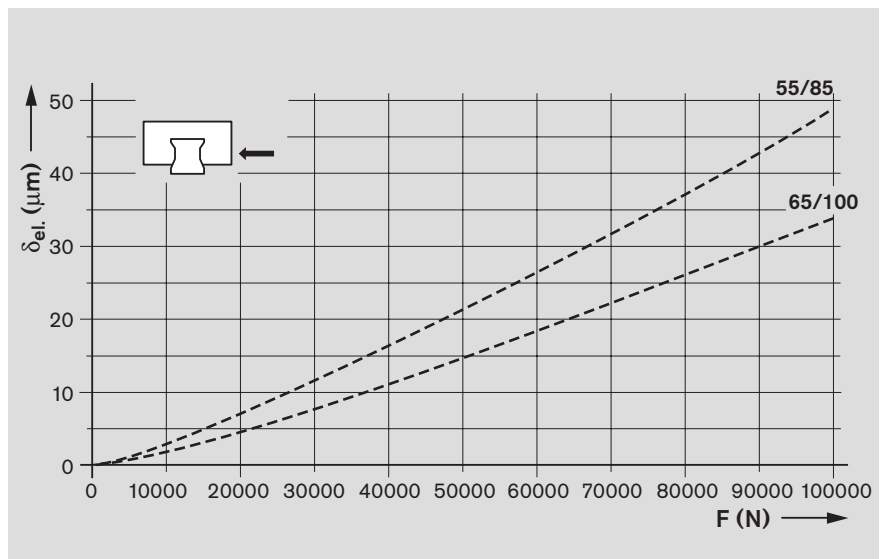
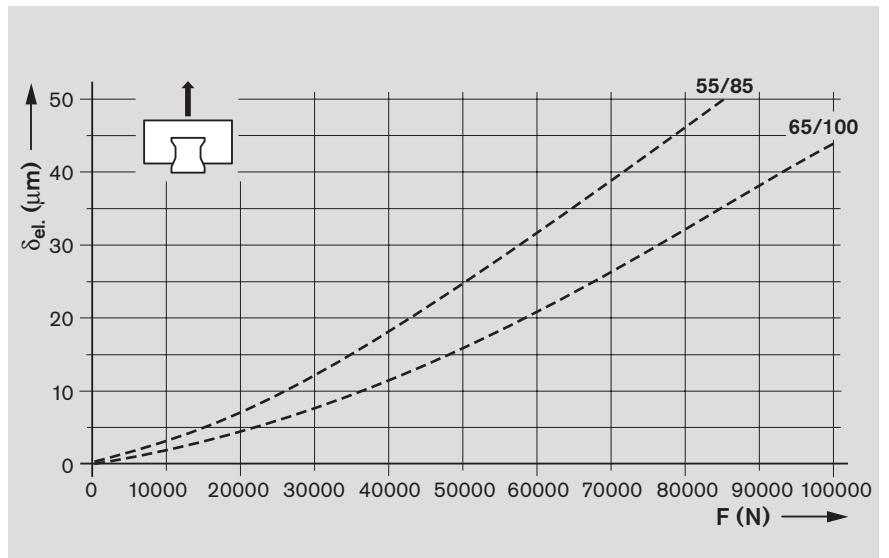
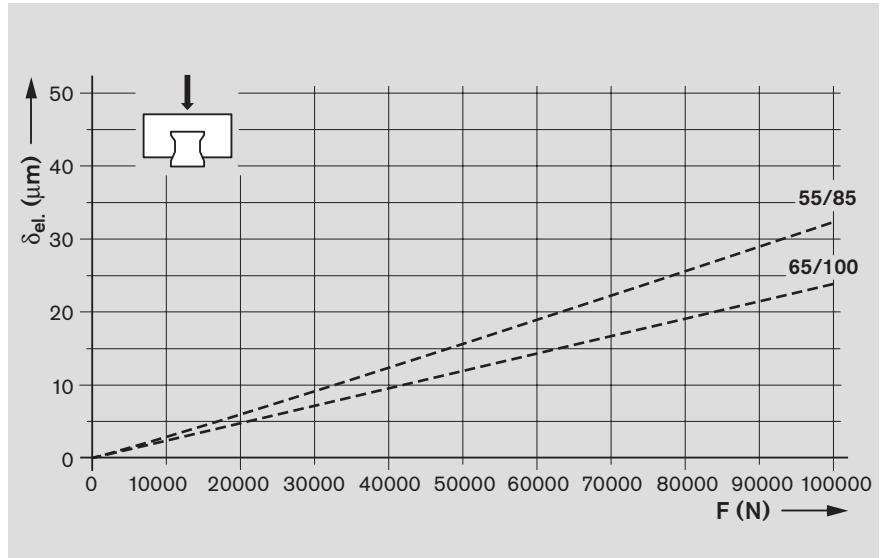

Preload class
C2 = preload 8% C

Key to graph

δ_{el.} = elastic deflection (μm)
F = load (N)

Wide Roller Rail Systems

Rigidity

Rigidity of the roller rail system at preload C3

Wide runner block BLS R1872

Size 55/85 ----- calculated values
 Size 65/100 ----- measured values

Runner block mounted using 8 screws and the upper reference edges only
 - All screws of strength class 12.9

1. Down load

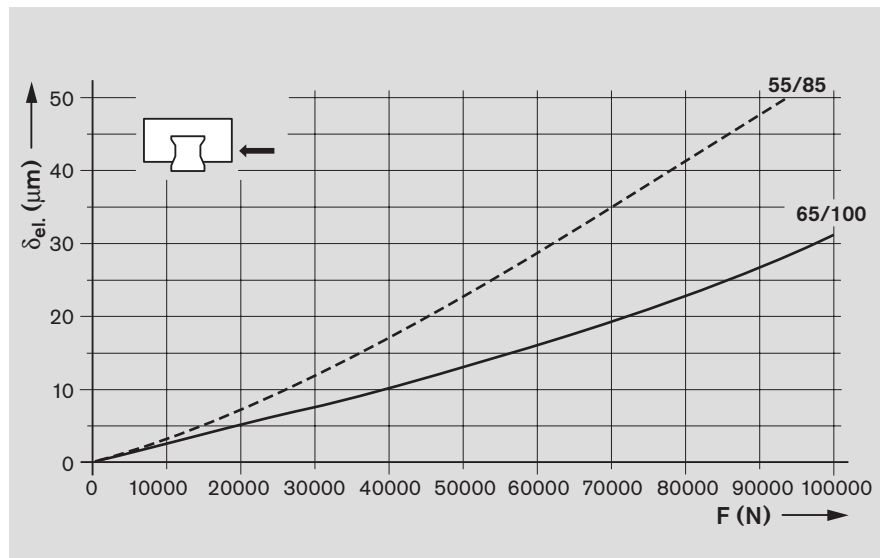
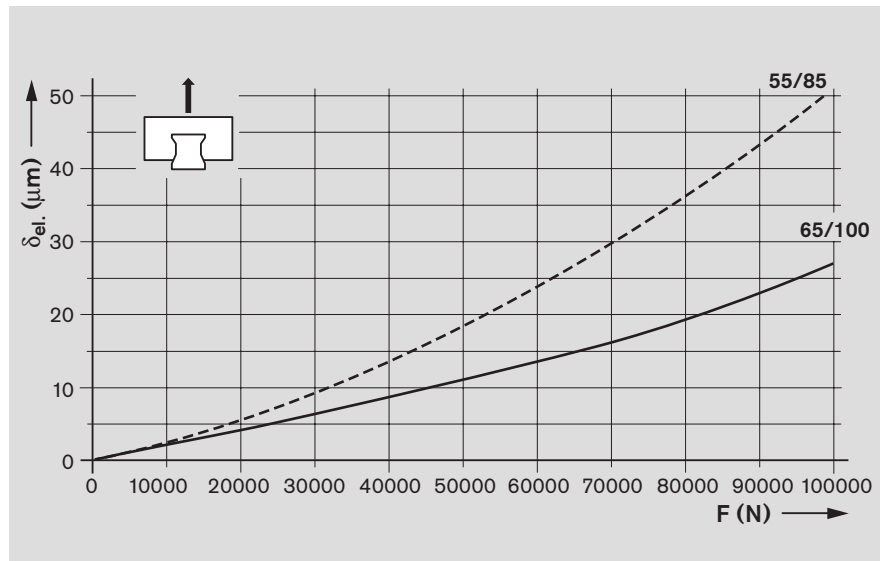
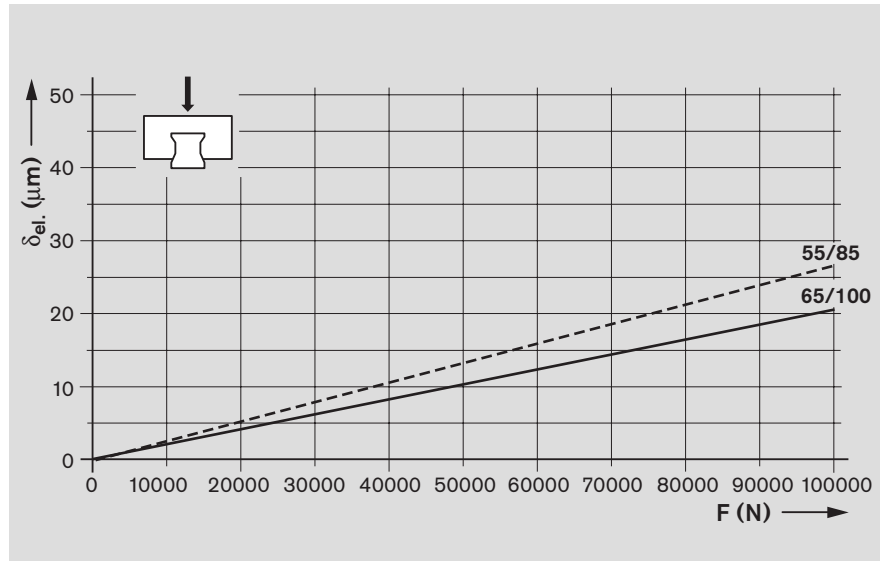

Preload class

Key to graph

δ_{el} = elastic deflection (μm)

Rigidity of the roller rail system at preload C3

Wide runner block BLS R1872

Size 55/85

----- calculated values

Size 65/100

————— measured values

Runner block mounted using 8 screws and all 4 reference edges (top and bottom)

- All screws of strength class 12.9

1. Down load

2. Lift-off load

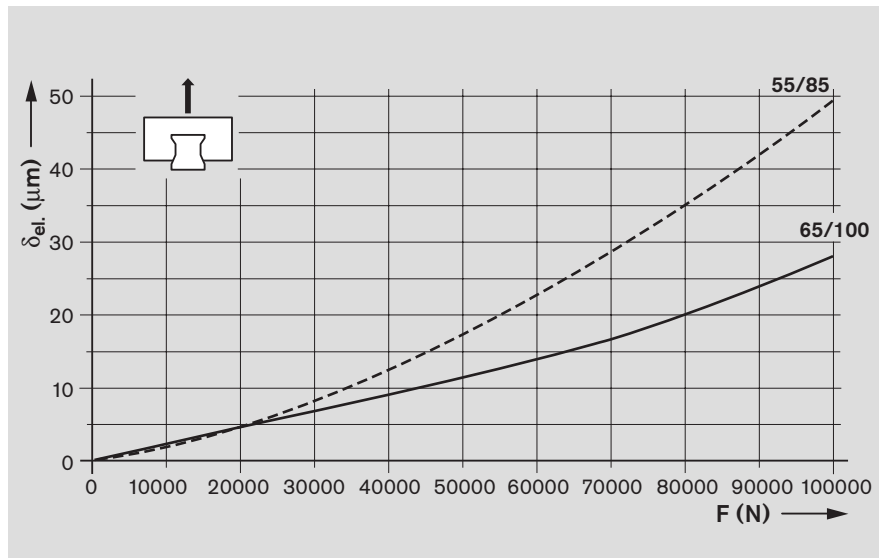
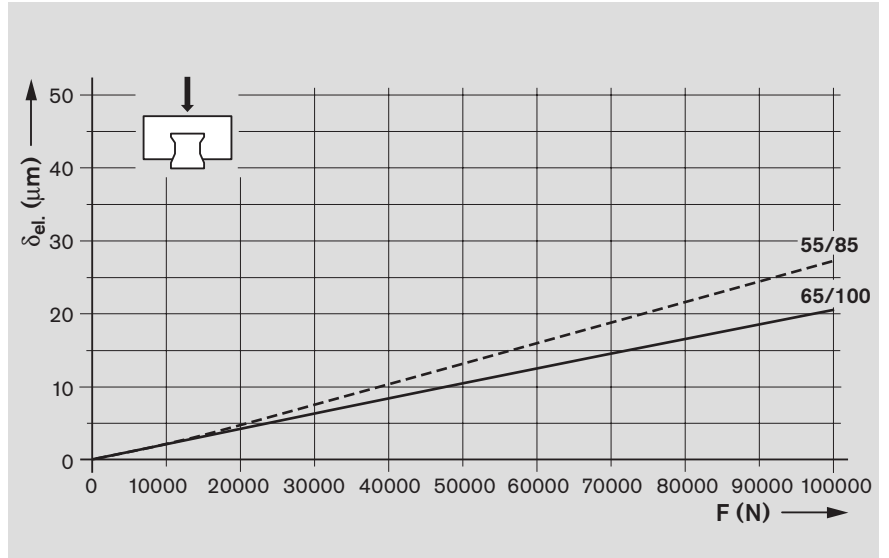

3. Side load

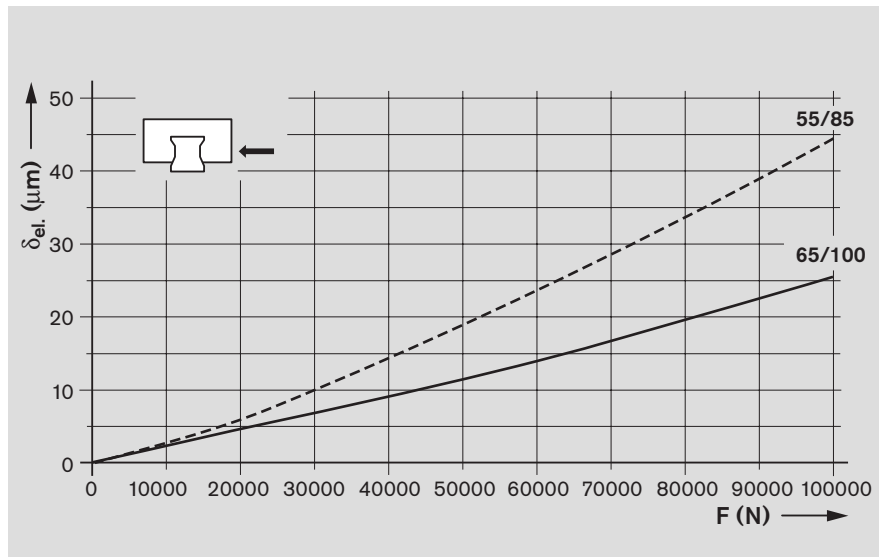

Preload class

C3 = preload 13% C

Key to graph

δ_{el.} = elastic deflection (μm)
 F = load (N)

Wide Roller Rail Systems

Wide Runner Blocks, Steel and Resist CR versions

Runner blocks, steel version
BLS R1872 ... 10
 Wide, long, standard height

Runner blocks, Resist CR vers.
BLS R1872 ... 60

Caution!

For runner blocks in Resist CR, matte silver hard chrome plated, different tolerances apply for the dimensions H and A_3 (see "Accuracy classes and their tolerances").

When hard chrome plated runner blocks with preload $C2 = 8\% C$ are combined with hard chrome plated guide rails, the preload increases to approx. 10% C.

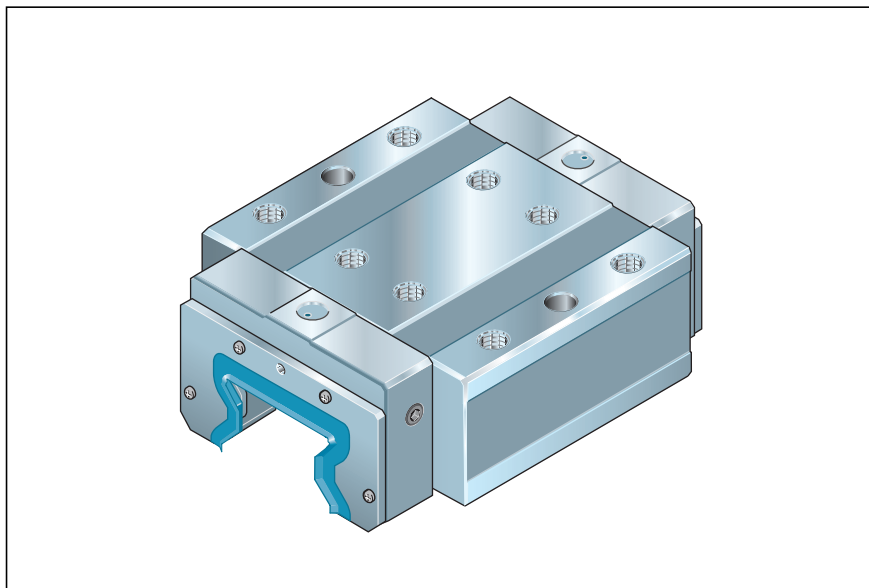

Wide runner blocks, steel version

Size	Accuracy class	Part numbers for preload class	
		C2	C3
55/85	H	R1872 523 10	–
	P	R1872 522 10	R1872 532 10
	SP	R1872 521 10	R1872 531 10
65/100	H	R1872 623 10	–
	P	R1872 622 10	R1872 632 10
	SP	R1872 621 10	R1872 631 10

Wide runner blocks, Resist CR version, matte silver hard chrome plated

Size	Accuracy class	Part numbers for preload class
		C2
55/85	H	R1872 523 60
65/100	H	R1872 623 60

Preload classes

C2 = preload 8% C

Note on dynamic load capacities and moments (see table)

The dynamic load capacities and moments are based on 100,000 m travel. However, a travel of just 50,000 m is often taken as a basis.

If this is the case, for comparison purposes: Multiply values C , M_t and M_L from the table by 1.23.

Size	Load capacities (N)		Moment loads (Nm)			
	C	C_0	M_t	M_{t0}	M_L	M_{L0}
55/85	165 000	345 300	7 450	15 650	4 030	8 440
65/100	265 500	525 600	14 300	28 350	7 960	15 760

Wide runner blocks BLS R1872 ... 10 and R1872 ... 60

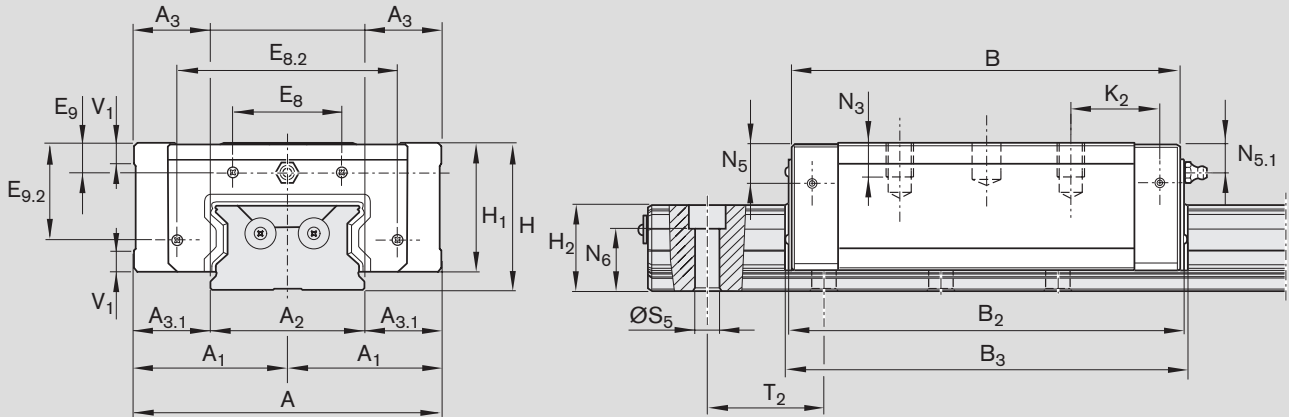

- a) For O-ring
 Size 55/85: dia. 7 · 1.5 (mm)
 Size 65/100: dia. 12 · 1.5 (mm)
 For lubrication from above, remove screw plug.
- b) Ready-drilled holes made for production purposes may already exist at this position only. These can be bored open.
- c) Lube nipple, thread M6: can be fitted on all sides.
 All lube ports are in metal.

Size	Dimensions (mm)																
	A	A ₁	A ₂	A ₃	A _{3.1}	B	B ₁	B ₂	B ₃	E ₁	E ₂	E ₃	E ₈	E _{8.2}	E ₉	E _{9.2}	
55/85	165	82.5	85	40	40	205.5	162.1	209.5	216	140	95	40	40	113.6	10.75	50.75	
65/100	200	100.0	100	50	50	254.0	194.0	258.0	264	172	110	50	72	143.0	19.30	65.00	

Size	Dimensions (mm)														Weight kg
	H	H ₁	H ₂ ¹⁾	K ₁	K ₂	N ₃	N ₅	N _{5.1}	N ₆ ^{±0.5}	S ₂	S ₅	T ₂ ²⁾	T ₃	V ₁	
55/85	80	68	47.85	43.55	46.55	19	19	19.0	31.2	M12	14	60	32	12	11.5
65/100	100	86	58.15	55.00	59.00	20	27	19.3	39.0	M14	16	75	38	15	20.7

1) Dimension H₂ with cover strip
 2) Dimension T₂ = hole spacing in the guide rail

Wide Roller Rail Systems

Wide Guide Rails, Steel and Resist CR versions

Guide rails, steel version
R1875 .6. ..

Guide rails, Resist CR version
R1873 .6. ..

With double-row mounting hole pattern, for mounting from above, with cover strip of stainless spring steel to EN 10088

Notes

Secure the cover strip! Screws and washers included in the supply scope. Please follow the mounting instructions! Send for the publication "Mounting Instructions for the Cover Strip".

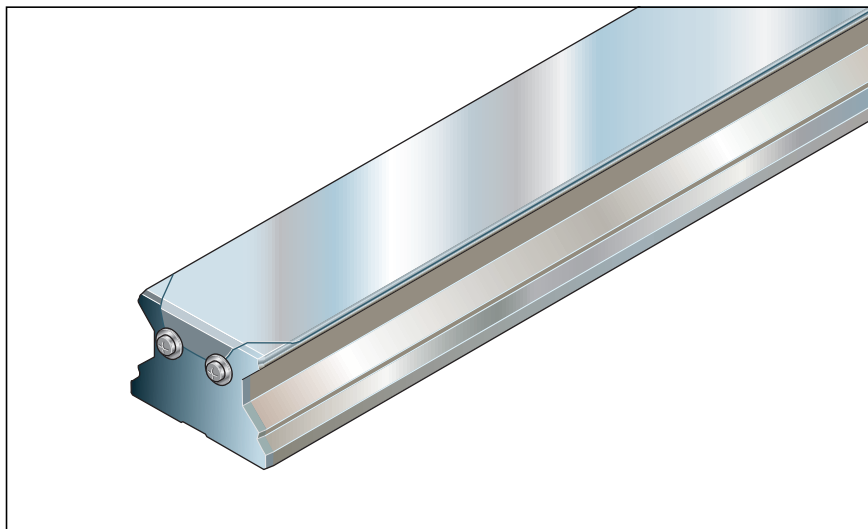

Wide guide rails, steel version

Size	Accuracy class	Guide rail One-piece Part number, Rail length L (mm)	Composite Part number and number of sections, Rail length L (mm)	Spacing T_2 mm	Recommended rail lengths Number of holes n_B / Rail length L (mm)
55/85	H	R1875 563 61,	R1875 563 6.,	60	acc. to formula $L = n_B \cdot T_2 - 4$ up to 66/3956 max.
	P	R1875 562 61,	R1875 562 6.,		
	SP	R1875 561 61,	R1875 561 6.,		
65/100	H	R1875 663 61,	R1875 663 6.,	75	acc. to formula $L = n_B \cdot T_2 - 4$ up to 53/3971 ¹⁾ max.
	P	R1875 662 61,	R1875 662 6.,		
	SP	R1875 661 61,	R1875 661 6.,		

1) Accuracy classes P and H up to approx. 80/5996; accuracy class SP on request.

Wide guide rails, Resist CR version, matte silver hard chrome plated

Size	Accuracy class	Guide rail One-piece Part number, Rail length L (mm)	Composite Part number and number of sections, Rail length L (mm)	Spacing T_2 mm	Recommended rail lengths Number of holes n_B / Rail length L (mm)
55/85	H	R1873 563 61,	–	60	acc. to formula $L = n_B \cdot T_2 - 4$ up to 66/3956 max.
		R1873 563 71,	R1873 563 7.,		
65/100	H	R1873 663 61,	–	75	acc. to formula $L = n_B \cdot T_2 - 4$ up to 53/3971 max.
		R1873 663 71,	R1873 663 7.,		

Caution!

For runner blocks and guide rails in Resist CR, matte silver hard chrome plated, different tolerances apply for the dimensions H and A_3 (see "Accuracy classes and their tolerances").

When hard chrome plated runner blocks with preload $C2 = 8\% C$ are combined with hard chrome plated guide rails, the preload increases to approx. 10% C.

Part numbers (coating)

- R1873 .6. .61 on request
(end faces, chamfers and thread uncoated)
- R1873 .6. .71
(end faces coated)

In composite Resist CR guide rails the joint faces are coated as well as the end faces.

Wide guide rails R1875 .6. .. and R1873 .6. ..

Guide rails with cover strip and tapped holes at the end faces.
Cover strip secured with screws and washers (included).

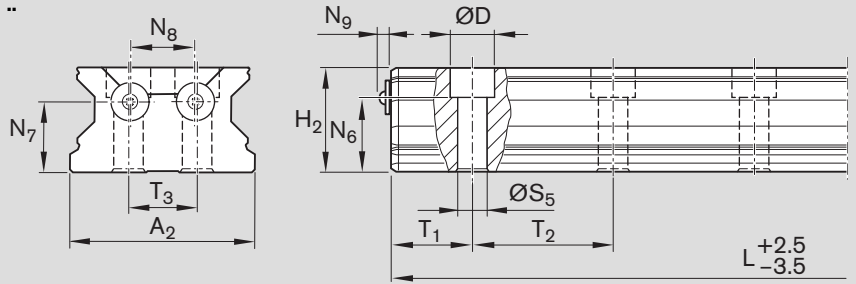

Size	Dimensions (mm)													Weight kg/m
	A ₂	D	H ₂ ¹⁾	L _{max}	N ₆ ^{±0.5}	N ₇	N ₈	N ₉	S ₅	T _{1 min} ²⁾	T _{1S} ³⁾	T ₂	T ₃	
55/85	85	20	47.85	4000	31.2	30	32	4.8	14	18	28.0	60	32	24.7
65/100	100	24	58.15	6000 ⁴⁾	39.0	40	37	4.8	16	20	35.5	75	38	34.7

- 1) Dimension H₂ with 0.3 mm cover strip
- 2) Rails with T₁ smaller than T_{1 min} have no tapped hole at end face for securing the strip! Secure the cover strip! Follow the mounting instructions!
- 3) Preferred dimension T_{1S} with tolerances +1/-1.5
- 4) Guide rails R1873 .6. .. in Resist CR in lengths of up to 4000 mm only

Ordering guide rails in recommended lengths

The following examples apply to all orders for wide guide rails.
Recommended rail lengths are delivered with priority.

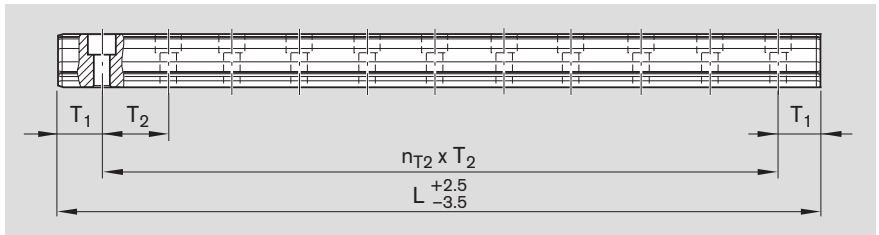

From the desired length to the recommended length

$$L = \frac{L_W}{T_2} \cdot T_2 - 4$$

Round up the quotient L_W/T_2 to the next

Example

$$L = \frac{2500 \text{ mm}}{60 \text{ mm}} \cdot 60 \text{ mm} - 4 \text{ mm}$$

$$L = 42 \cdot 60 \text{ mm} - 4 \text{ mm}$$

$$L = 2516 \text{ mm}$$

Notes on ordering examples

If the preferred dimension T_{1S} cannot be used:

- Select an end space T₁ between T_{1S} and T_{1 min}.
- Do not go below the minimum spacing T_{1 min}!
(T₁, T_{1 min}, T_{1S} are the same at either end of the rail.)

$$L = n_B \cdot T_2 - 4$$

Basis: number of holes

$$L = n_{T_2} \cdot T_2 + 2 \cdot T_{1S}$$

Basis: number of spaces

Ordering example 1 (up to L_{max})

- Wide guide rail size 55/85 with cover strip
- Accuracy class P
- Calculated rail length 2516 mm,
(41 · T₂, preferred dimension T_{1S} = 28 mm; number of holes n_B = 42)

Ordering data

Part number, rail length (mm)
T₁ / n_{T2} · T₂ / T₁ (mm)

R1875 562 61, 2516 mm
28 / 41 · 60 / 28 mm

- L = recommended rail length (mm)
- L_W = desired rail length (mm)
- T₂ = hole spacing¹⁾ (mm)
- T_{1S} = preferred dimension¹⁾ (mm)
- n_B = number of holes
- n_{T2} = number of spaces
- 1) See tables for values

Ordering example 2 (over L_{max})

- Wide guide rail size 55/85 with cover strip
- Accuracy class P
- Calculated rail length 7556 mm, 2 sections
(125 · T₂, preferred dimension T_{1S} = 28 mm; number of holes n_B = 126)

Ordering data

Part number and number of sections, rail length (mm)
T₁ / n_{T2} · T₂ / T₁ (mm)

R1875 562 62, 7556 mm
28 / 125 · 60 / 28 mm

Rail lengths greater than L_{max} are made up of matching rail sections mounted end to end.

Heavy Duty Roller Rail Systems

Product Description

Outstanding features

- Heavy duty runner blocks for applications requiring extremely high load capacities
- Maximum rigidity under load from all directions
- Improved rigidity under lift-off and side loading conditions through three additional mounting screw holes at the center of the runner block
- High torque capacity
- Uniform guide rail profile in various versions allows unrestricted interchangeability and combinability of components across all runner block variants.
- Mounting of attachments to runner block from above or below

Further highlights

- Lube ports on all sides for maximum ease of maintenance
- Novel lube duct design minimizes lubricant consumption.
- Runner blocks made from antifriction bearing steel, with hardened and ground raceways (guide rails also with hardened raceways and ground on all sides)
- Smooth running thanks to optimized roller recirculation and guidance
- Optimized entry-section geometry and high number of rollers per track minimizes variation in elastic deflection.
- Aluminum or plastic end caps
- End seals integrated as standard for better sealing of all running tracks and to protect plastic parts

Options

- Corrosion-resistant heavy duty runner blocks and guide rails in Resist CR, matte silver hard chrome plated, available in accuracy class H (preload C2 and C3)

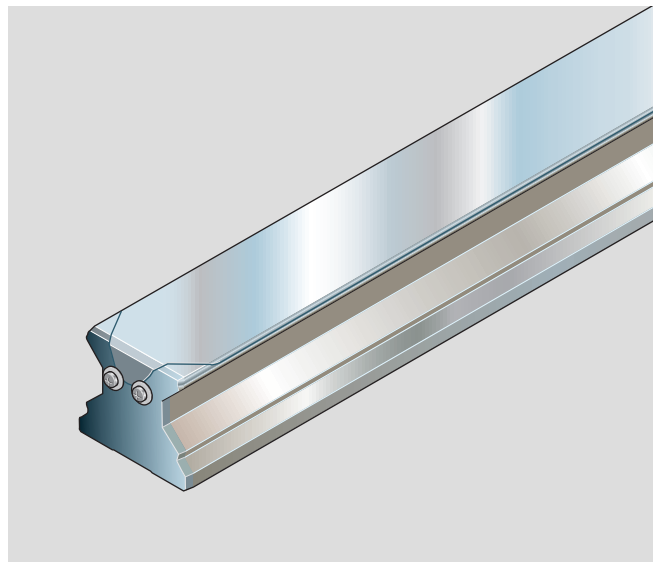

Proven cover strip for guide rail mounting holes

- A **single** cover for all holes – saves time and money
- Stainless spring steel to EN 10088
- Easy to fit – simply clip on and secure

Heavy Duty Roller Rail System

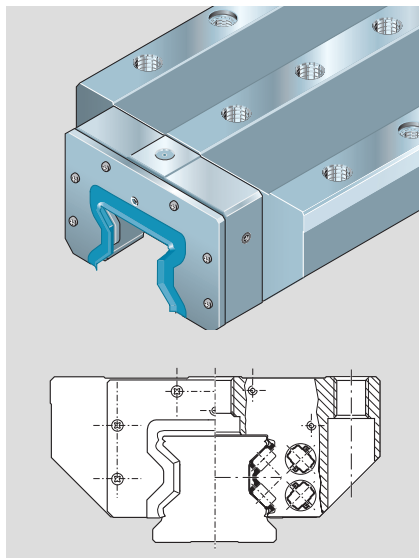
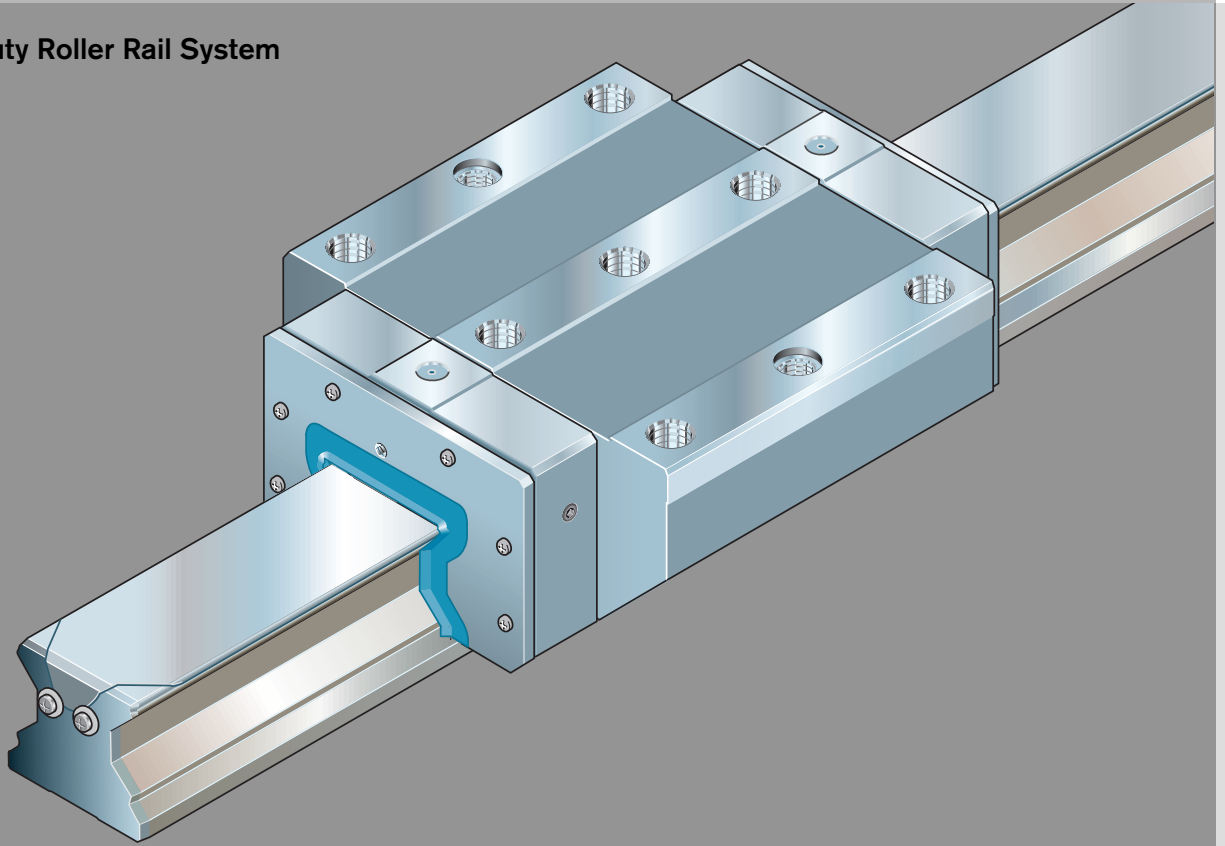

Heavy Duty Roller Rail Systems for heavy duty applications

- Aluminum or plastic end caps
- End seals as standard
- Smooth running thanks to optimized roller recirculation and guidance

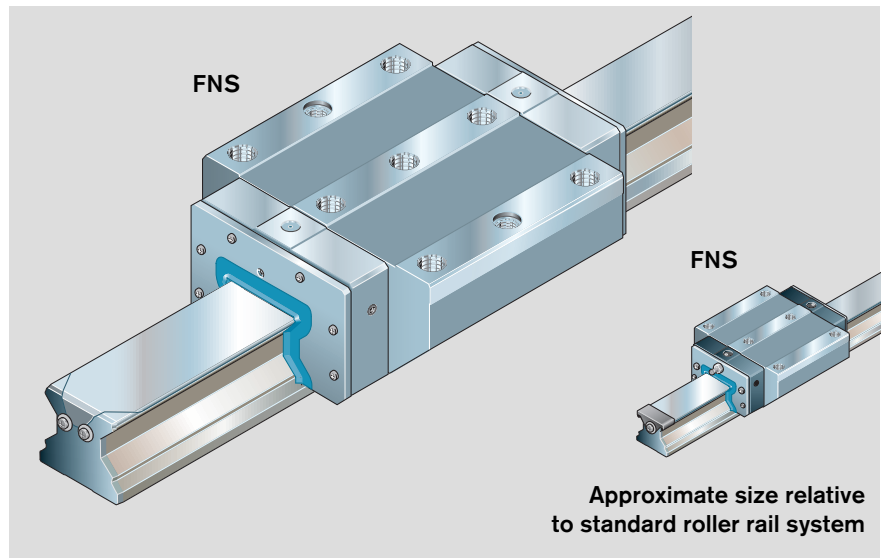

Approximate size comparison: Heavy Duty vs. Standard Roller Rail System (example)

- Heavy duty runner block FNS R1861 on heavy duty guide rail R1835 (size 125)
- Standard runner block FNS R1851 on standard guide rail R1805 (size 45)

Heavy Duty Roller Rail Systems

Rigidity

Rigidity of the roller rail system at preload C3

Heavy duty runner block FNS R1861

Sizes 100 and 125

----- calculated values

Runner block mounted using 9 screws:

- 6 outer screws of strength class 12.9
- 3 centerline screws of strength class 8.8

1. Down load

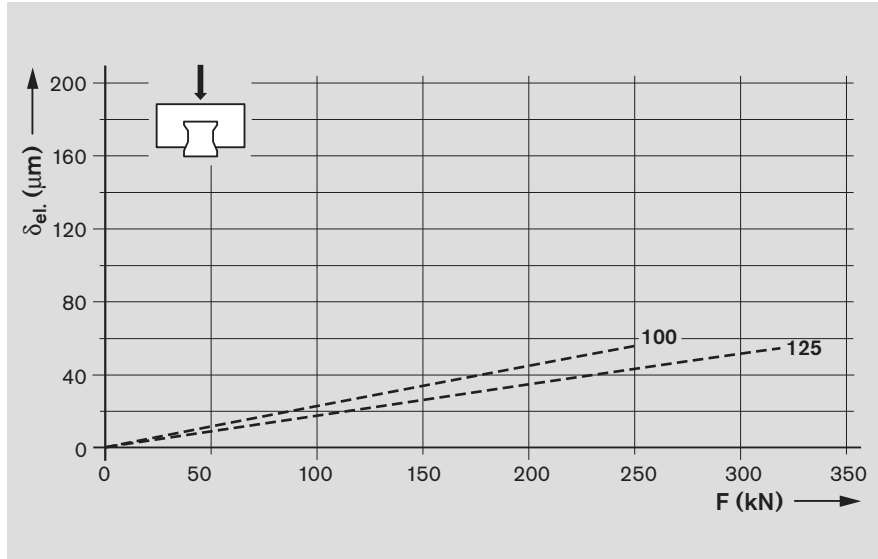

2. Lift-off load

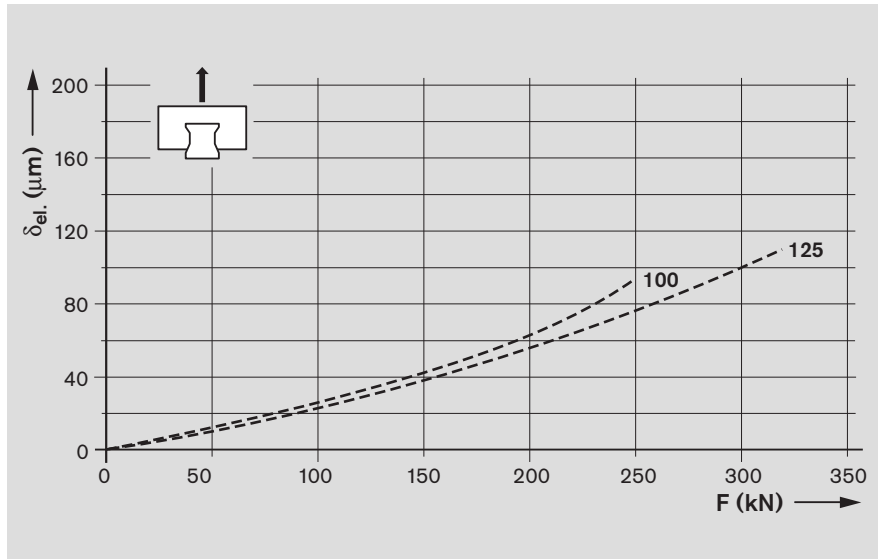

3. Side load

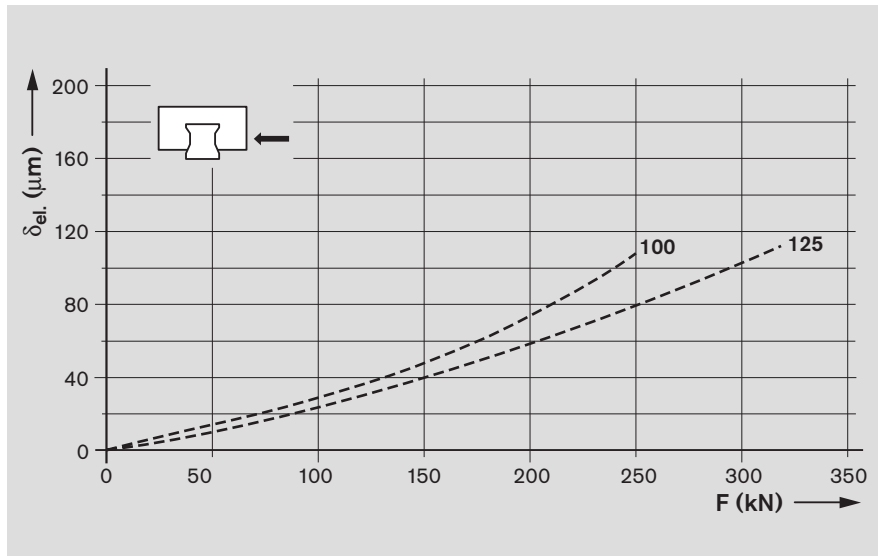

Preload class

C3 = preload 13% C

Key to graph

δ_{el.} = elastic deflection (μm)

Rigidity of the roller rail system at preload C3

Heavy duty runner block FLS R1863

Sizes 100 and 125

————— measured values
 - - - - - calculated values

Runner block mounted using

9 screws:

- 6 outer screws of strength class 12.9
- 3 centerline screws of strength class 8.8

1. Down load

2. Lift-off load

3. Side load

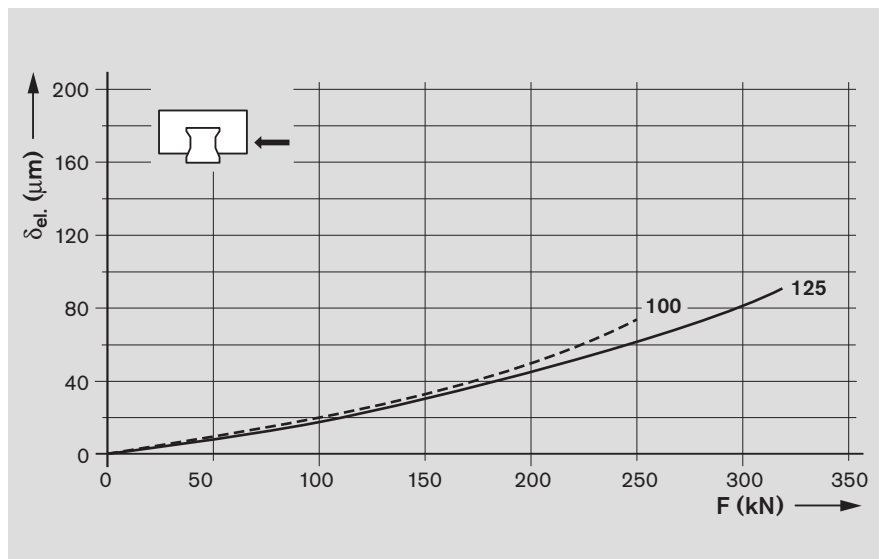
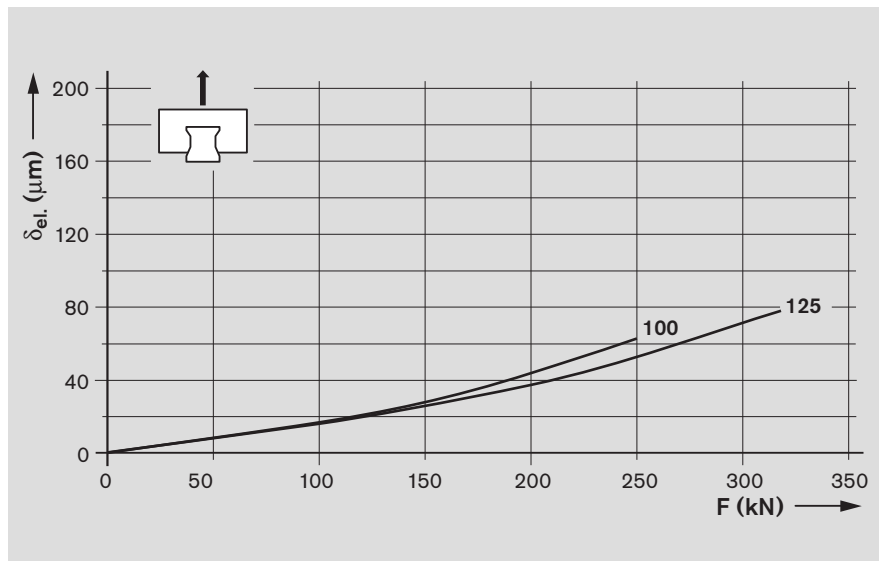
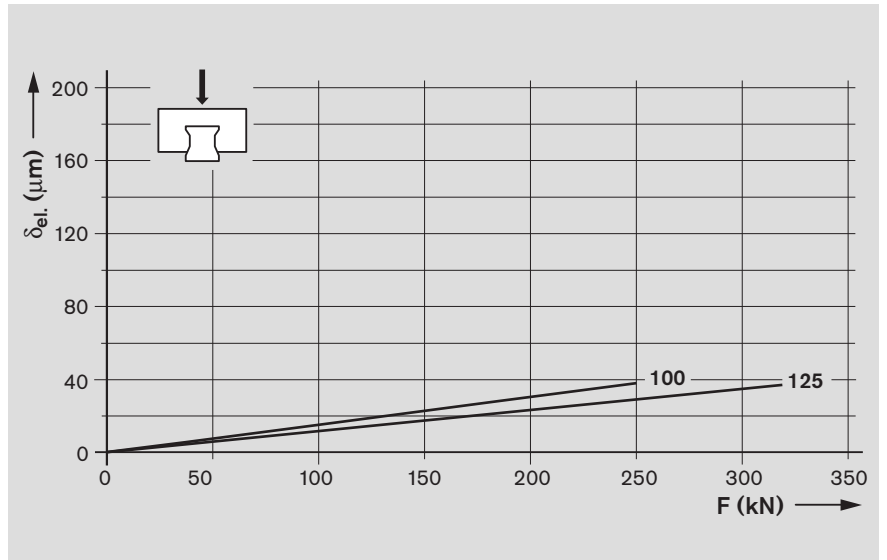

Preload class
 C3 = preload 13% C

Key to graph

δ_{el.} = elastic deflection (μm)
 F = load (kN)

Heavy Duty Roller Rail Systems

Heavy Duty Runner Blocks, Steel and Resist CR versions

**Runner blocks, steel version
FNS R1861 ... 10
Flanged, normal, standard
height**

**Runner blocks, Resist CR vers.
FNS R1861 ... 60**

Caution!

For runner blocks in Resist CR, matte silver hard chrome plated, different tolerances apply for the dimensions H and A₃ (see "Accuracy classes and their tolerances").

When hard chrome plated runner blocks with preload C2 = 8% C (or C3 = 13% C) are combined with hard chrome plated guide rails, the preload increases to approx. 10% C (or approx. 15% C).

Notes

For short-stroke applications (< 2 · B₁), use additional lube ports:
– Size 125: B₄ and N₇

All lube ports with thread M8x1 (tapped holes in the metal for size 125).

Preload classes

C2 = preload 8% C
C3 = preload 13% C

Note on dynamic load capacities and moments (see table)

The dynamic load capacities and moments are based on 100,000 m travel. However, a travel of just 50,000 m is often taken as a basis. If this is the case, for comparison purposes: Multiply values C, M_t and M_L from the table by 1.23.

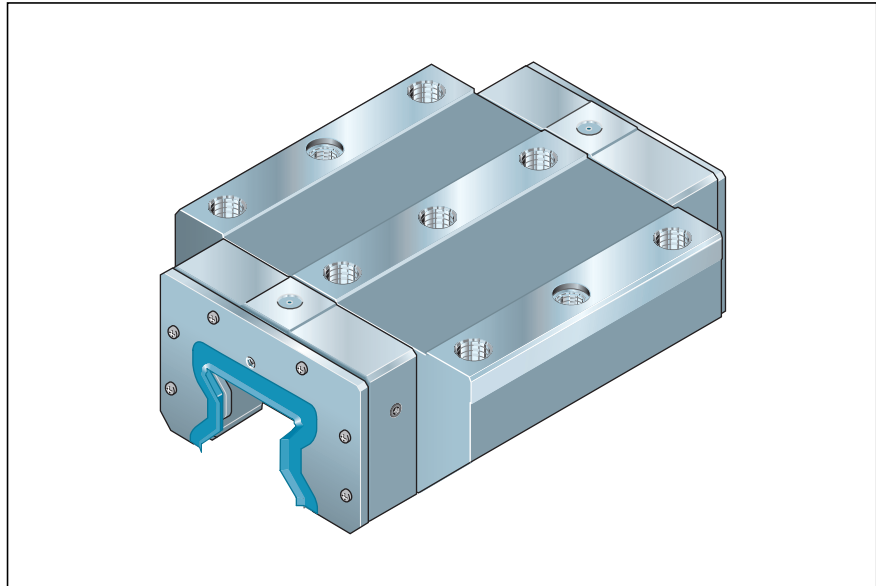

Heavy duty runner blocks, steel version

Size	Accuracy class	Part numbers for preload class	
		C2	C3
100	H	R1861 223 10	R1861 233 10
	P	R1861 222 10	R1861 232 10
	SP	R1861 221 10	R1861 231 10
125	H	R1861 323 10	R1861 333 10
	P	R1861 322 10	R1861 332 10

Heavy duty runner blocks, Resist CR version, matte silver hard chrome plated

Size	Accuracy class	Part numbers for preload class	
		C2	C3
100	H	R1861 223 60	R1861 233 60
125	H	R1861 323 60	R1861 333 60

Size	Load capacities (N)		Moment loads (Nm)			
	C	C ₀	M _t	M _{t0}	M _L	M _{L0}
100	461 000	811 700	25 720	45 290	13 550	23 850
125	757 200	1 324 000	54 520	95 330	29 660	51 860

Heavy duty runner blocks FNS R1861 ... 10 and FNS R1861 ... 60

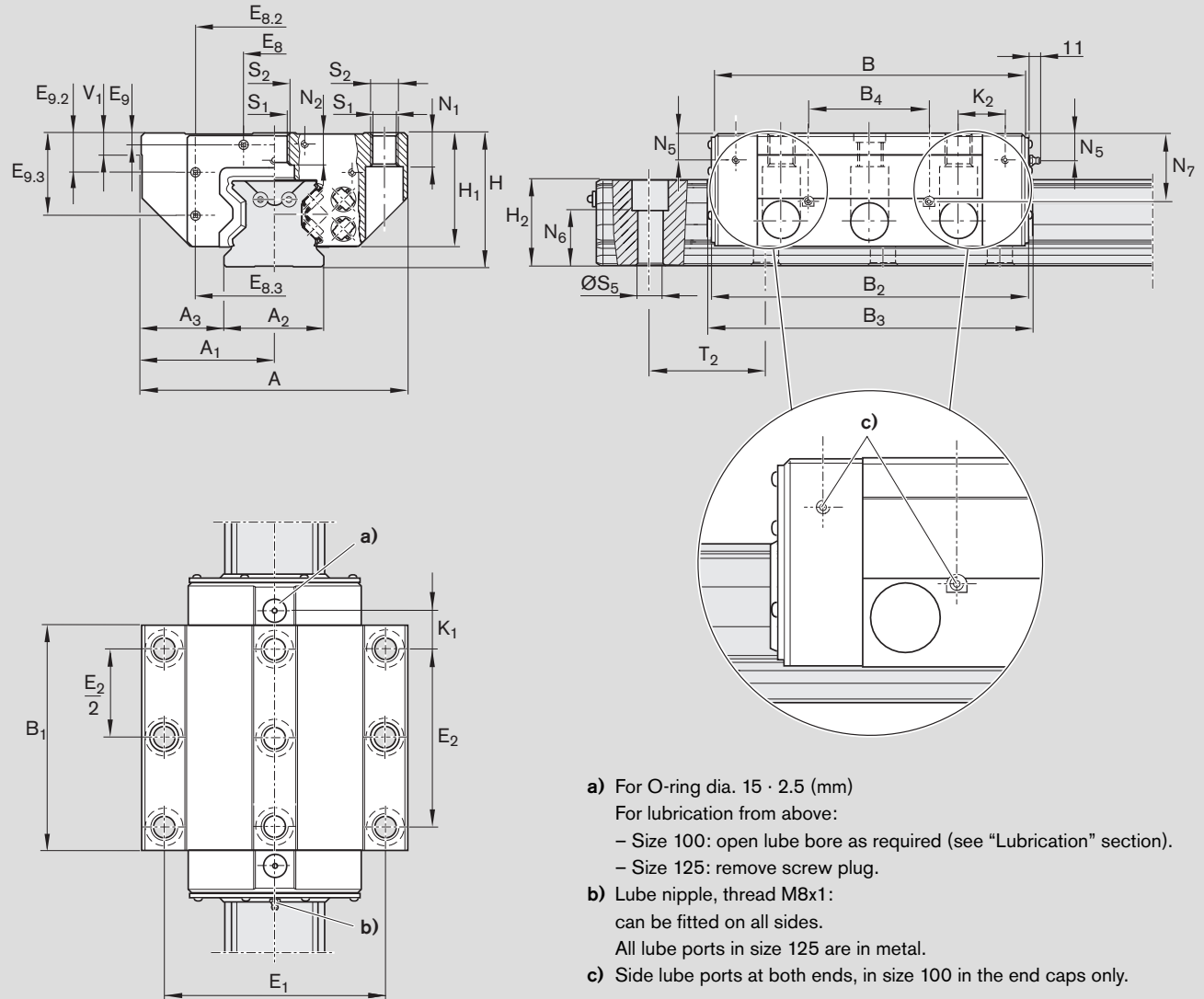

- a)** For O-ring dia. 15 · 2.5 (mm)
For lubrication from above:
 - Size 100: open lube bore as required (see "Lubrication" section).
 - Size 125: remove screw plug.
- b)** Lube nipple, thread M8x1:
can be fitted on all sides.
All lube ports in size 125 are in metal.
- c)** Side lube ports at both ends, in size 100 in the end caps only.

Size	Dimensions (mm)																
	A	A ₁	A ₂	A ₃	B	B ₁	B ₂	B ₃	B ₄	E ₁	E ₂	E ₈	E _{8.2}	E _{8.3}	E ₉	E _{9.2}	E _{9.3}
100	250	125	100	75.0	296.6	204	301.5	309.5	-	200	150	64	130	162.6	9	29.4	70
125	320	160	125	97.5	371.0	255	377.0	386.5	130	270	205	80	205	205.0	12	40.0	92

Size	Dimensions (mm)															Weight kg
	H	H ₁	H ₂ ¹⁾	K ₁	K ₂	N ₁	N ₂	N ₅	N ₆ ^{±0.5}	N ₇	S ₁	S ₂	S ₅	T ₂	V ₁	
100	120	105.0	87.3	39.5	39.5	30	22	17.5	55.0	-	17.5	M20	26	105	20	32.0
125	160	135.5	115.3	50.0	50.0	45	29	29.0	74.5	92	25.0	M27	33	120	25	62.1

1) Dimension H₂ with cover strip

Heavy Duty Roller Rail Systems

Heavy Duty Runner Blocks, Steel and Resist CR versions

Runner blocks, steel version
FLS R1863 ... 10
 Flanged, long, standard height

Runner blocks, Resist CR vers.
FLS R1863 ... 60

Caution!

For runner blocks in Resist CR, matte silver hard chrome plated, different tolerances apply for the dimensions H and A₃ (see "Accuracy classes and their tolerances")

When hard chrome plated runner blocks with preload C2 = 8% C (or C3 = 13% C) are combined with hard chrome plated guide rails, the preload increases to approx. 10% C (or approx. 15% C).

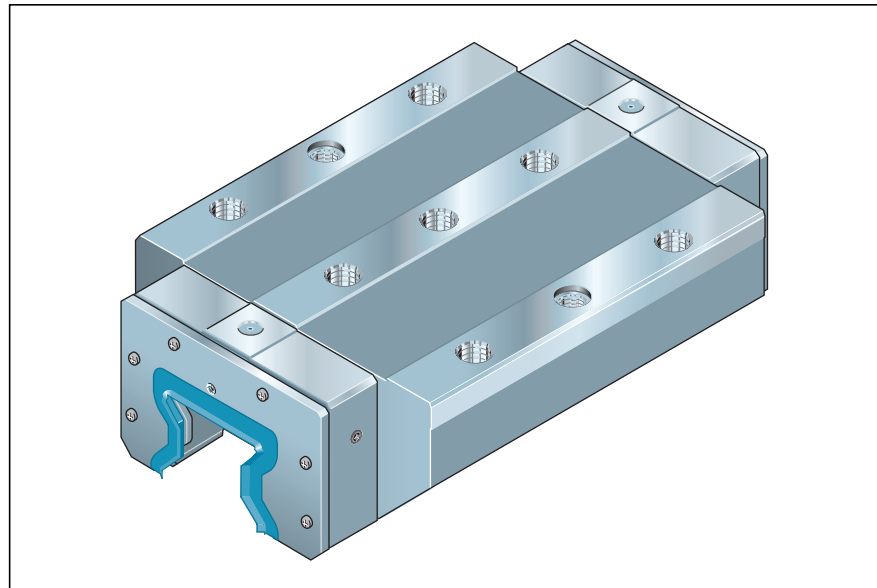

Notes

For short-stroke applications (< 2 · B₁), use additional lube ports:
 – Size 125: B₄ and N₇

All lube ports with thread M8x1 (tapped holes in the metal for size 125).

Heavy duty runner blocks, steel version

Size	Accuracy class	Part numbers for preload class	
		C2	C3
100	H	R1863 223 10	R1863 233 10
	P	R1863 222 10	R1863 232 10
	SP	R1863 221 10	R1863 231 10
125	H	R1863 323 10	R1863 333 10
	P	R1863 322 10	R1863 332 10

Heavy duty runner blocks, Resist CR version, matte silver hard chrome plated

Size	Accuracy class	Part numbers for preload class	
		C2	C3
100	H	R1863 223 60	R1863 233 60
125	H	R1863 323 60	R1863 333 60

Preload classes

C2 = preload 8% C

C3 = preload 13% C

Note on dynamic load capacities and moments (see table)

The dynamic load capacities and moments are based on 100,000 m travel. However, a travel of just 50,000 m is often taken as a basis.

If this is the case, for comparison purposes: Multiply values C, M_t and M_L from the table by 1.23.

Size	Load capacities (N)		Moment loads (Nm)			
	C	C ₀	M _t	M _{t0}	M _L	M _{L0}
100	632 000	1 218 000	35 300	67 900	27 200	52 400
125	1 020 000	1 941 900	73 440	139 820	57 330	109 150

Heavy duty runner blocks FLS R1863 ... 10 and FLS R1863 ... 60

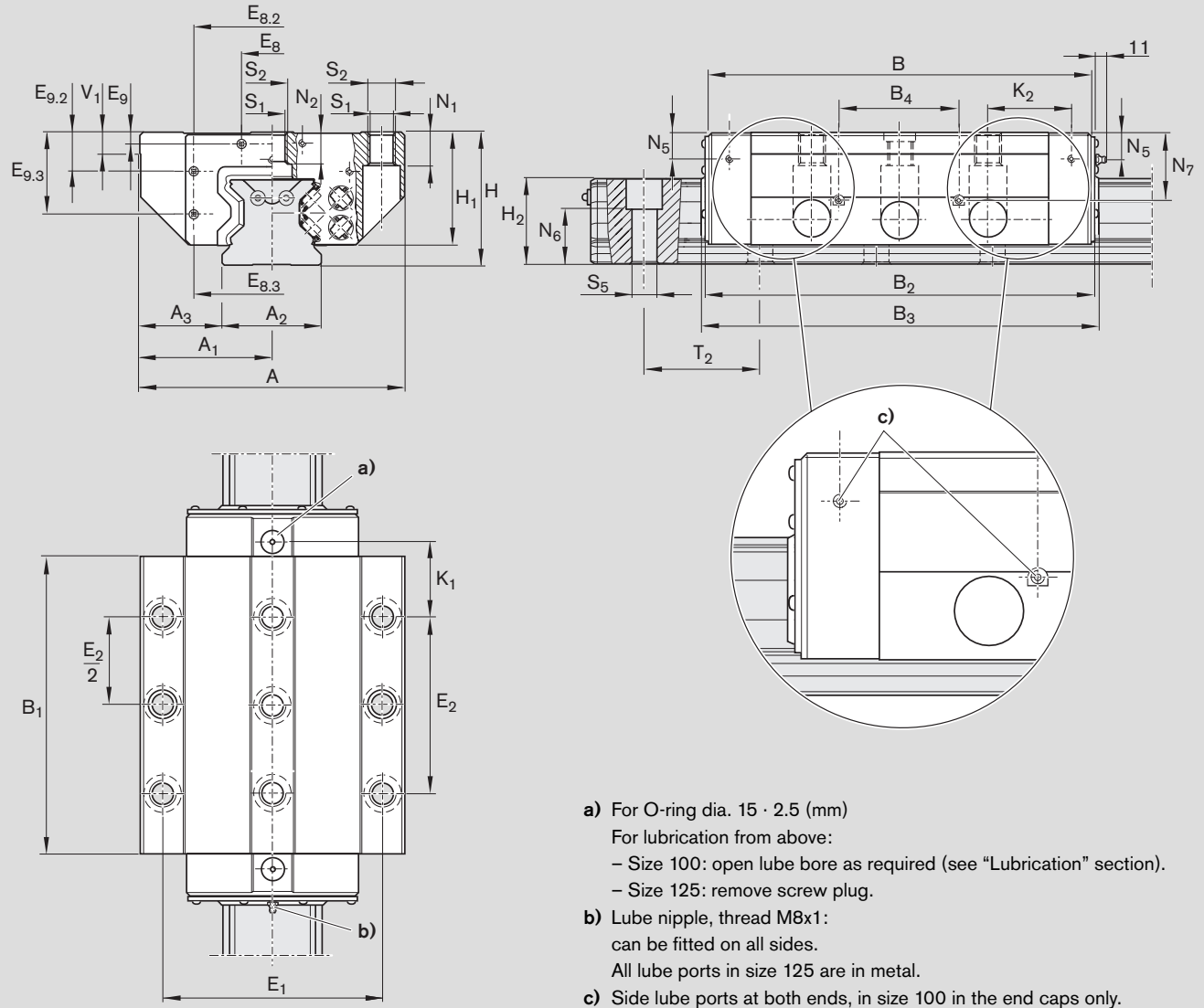

- a) For O-ring dia. 15 · 2.5 (mm)
For lubrication from above:
– Size 100: open lube bore as required (see “Lubrication” section).
– Size 125: remove screw plug.
- b) Lube nipple, thread M8x1:
can be fitted on all sides.
All lube ports in size 125 are in metal.
- c) Side lube ports at both ends, in size 100 in the end caps only.

Size	Dimensions (mm)																
	A	A ₁	A ₂	A ₃	B	B ₁	B ₂	B ₃	B ₄	E ₁	E ₂	E ₈	E _{8.2}	E _{8.3}	E ₉	E _{9.2}	E _{9.3}
100	250	125	100	75.0	380.5	288	385.5	393.5	–	200	230	64	130	162.6	9	29.4	70
125	320	160	125	97.5	476.0	360	482.0	491.5	150	270	205	80	205	205.0	12	40.0	92

Size	Dimensions (mm)															Weight kg
	H	H ₁	H ₂ ¹⁾	K ₁	K ₂	N ₁	N ₂	N ₅	N ₆ ^{±0.5}	N ₇	S ₁	S ₂	S ₅	T ₂	V ₁	
100	120	105.0	87.3	41.5	47.4	30	22	17.5	55.0	–	17.5	M20	26	105	20	42.0
125	160	135.5	115.3	102.5	102.5	45	29	29.0	74.5	92	25.0	M27	33	120	25	89.8

1) Dimension H₂ with cover strip

Heavy Duty Roller Rail Systems

Heavy Duty Guide Rails, Steel and Resist CR versions

Guide rails, steel version
R1835 .6. ..

Guide rails, Resist CR version
R1865 .6. ..

For mounting from above,
with cover strip of stainless spring
steel to EN 10088

Notes

Secure the cover strip!

The cover strip, screws and washers
are included in the supply scope; they
are supplied along with the rails but in
a separate packing unit.

Please follow the mounting instructions!
Send for the publication "Mounting
Instructions for the Cover Strip".

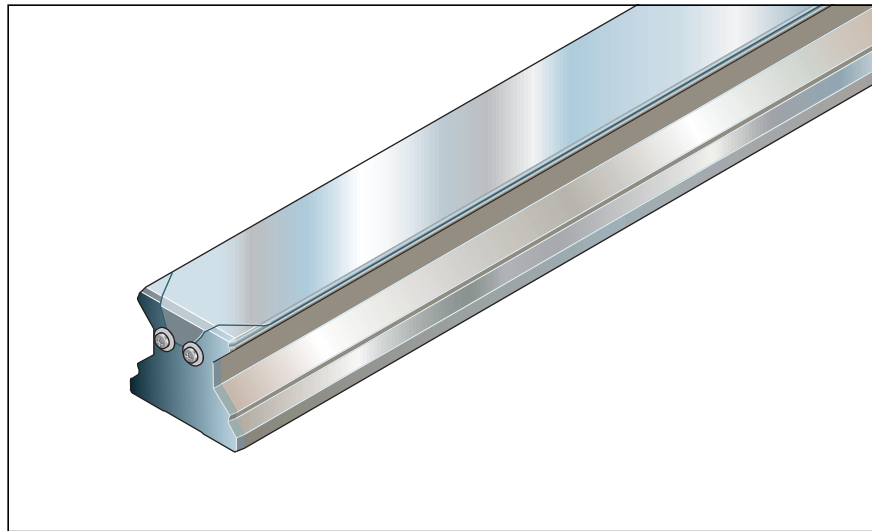

Heavy duty guide rails, steel version

Size	Accuracy class	Guide rail		Spacing T_2 mm	Recommended rail lengths Number of holes n_B / Rail length L (mm)
		One-piece Part number, Rail length L (mm)	Composite Part number and number of sections, Rail length L (mm)		
100	H	R1835 263 61,	R1835 263 6.,	105	acc. to formula $L = n_B \cdot T_2 - 7$ up to 35/3668 ¹⁾ max.
	P	R1835 262 61,	R1835 262 6.,		
	SP	R1835 261 61,	R1835 261 6.,		
125	H	R1835 363 61,	R1835 363 6.,	120	acc. to formula $L = n_B \cdot T_2 - 7$ up to 22/2633 ²⁾ max.
	P	R1835 362 61,	R1835 362 6.,		

Heavy duty guide rails, Resist CR version, matte silver hard chrome plated

Size	Accuracy class	Guide rail		Spacing T_2 mm	Recommended rail lengths Number of holes n_B / Rail length L (mm)
		One-piece Part number, Rail length L (mm)	Composite Part number and number of sections, Rail length L (mm)		
100	H	R1865 263 61,	–	105	acc. to formula $L = n_B \cdot T_2 - 7$ up to 35/3668 ¹⁾ max.
		R1865 263 71,	R1865 263 7.,		
125	H	R1865 363 61,	–	120	acc. to formula $L = n_B \cdot T_2 - 7$ up to 22/2633 ²⁾ max.
		R1865 363 71,	R1865 363 7.,		

1) Size 100: For lengths of 3668 mm and over, please consult us.

2) Size 125: For lengths of 2633 mm and over, please consult us.

3) Accuracy classes P and SP on request

Caution!

For runner blocks and guide rails in
Resist CR, matte silver hard chrome
plated, different tolerances apply for the
dimensions H and A_3 (see "Accuracy
classes and their tolerances").

When hard chrome plated runner
blocks with preload $C2 = 8\% C$ (or
 $C3 = 13\% C$) are combined with hard
chrome plated guide rails, the preload
increases to approx. 10% C (or approx.
15% C).

Part numbers (coating)

- R1865 .6. .61 on request
(end faces, chamfers and threads
uncoated)
- R1865 .6. 71
(end faces coated)

In composite guide rails the joint faces
are hard chrome plated as well as the
end faces.

Heavy duty guide rails R1835 .6. .. and R1865 .6. ..

Guide rails with cover strip and tapped holes at the end faces.
Cover strip secured with screws and washers (included).

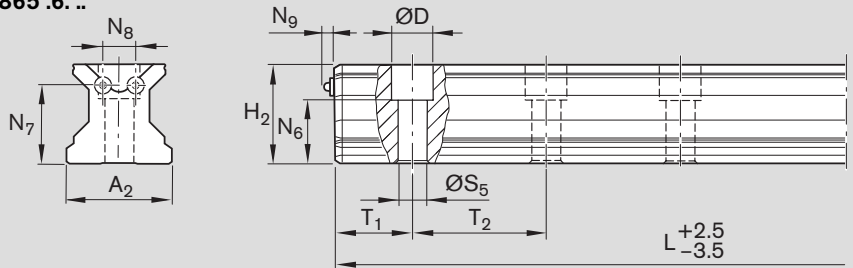

Size	Dimensions (mm)											Weight kg/m	
	A ₂	D	H ₂ ¹⁾	L _{max} ²⁾	N ₆ ^{±0.5}	N ₇	N ₈	N ₉	S ₅	T _{1 min} ³⁾	T _{1S} ⁴⁾		T ₂
100	100	40	87.3	3900	55.0	65	28	4.8	26	35	49.0	105	42.5
125	125	49	115.3	2900	74.5	91	38	4.8	33	40	56.5	120	75.6

- 1) Dimension H₂ with 0.3 mm cover strip
- 2) Size 100: For lengths of 3668 mm and over, please consult us.
- 3) Size 125: For lengths of 2633 mm and over, please consult us.
- 4) Rails with T₁ smaller than T_{1 min} have no tapped hole at end face for securing the strip! Secure the cover strip! Follow the mounting instructions!
- 5) Preferred dimension T_{1S} with tolerances +1/-1.5

Ordering guide rails in recommended lengths

The following examples apply to all orders for heavy duty guide rails. Recommended rail lengths are delivered with priority.

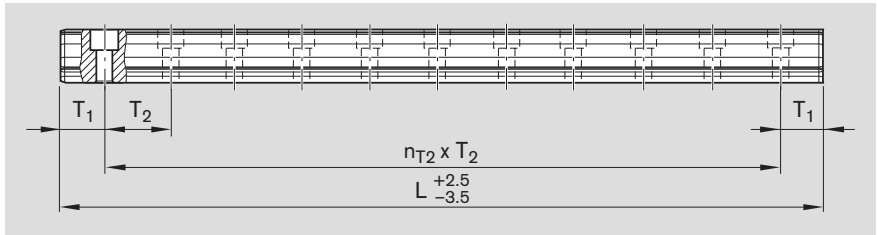

From the desired length to the recommended length

$$L = \frac{L_W}{T_2} \cdot T_2 - 7$$

Round up the quotient L_W/T_2 to the next

Example

$$L = \frac{1650 \text{ mm}}{120 \text{ mm}} \cdot 120 \text{ mm} - 7 \text{ mm}$$

$$L = 14 \cdot 120 \text{ mm} - 7 \text{ mm}$$

$$L = 1673 \text{ mm}$$

Notes on ordering examples

If the preferred dimension T_{1S} cannot be used:

- Select an end space T₁ between T_{1S} and T_{1 min}.
- Do not go below the minimum spacing T_{1 min}!
(T₁, T_{1 min}, T_{1S} are the same at either end of the rail.)

$$L = n_B \cdot T_2 - 7$$

Basis: number of holes

$$L = n_{T_2} \cdot T_2 + 2 \cdot T_{1S}$$

Basis: number of spaces

Ordering example 1 (up to L_{max})

- Heavy duty guide rail size 125 with cover strip
- Accuracy class P
- Calculated rail length 1673 mm,
(13 · T₂, preferred dimension T_{1S} = 56.5 mm; number of holes n_B = 14)

Ordering data

Part number, rail length (mm)
T₁ / n_{T2} · T₂ / T₁ (mm)

R1835 362 61, 1637 mm
56.5 / 13 · 120 / 56.5 mm

- L = recommended rail length (mm)
- L_W = desired rail length (mm)
- T₂ = hole spacing¹⁾ (mm)
- T_{1S} = preferred dimension¹⁾ (mm)
- n_B = number of holes
- n_{T2} = number of spaces

Ordering example 2 (over L_{max})

- Heavy duty guide rail size 125 with cover strip
- Accuracy class P
- Calculated rail length 5033 mm, 2 sections
(41 · T₂, preferred dimension T_{1S} = 56.5 mm; number of holes n_B = 42)

Ordering data

Part number and number of sections, rail length (mm)
T₁ / n_{T2} · T₂ / T₁ (mm)

R1835 362 62, 5033 mm
56.5 / 41 · 120 / 56.5 mm

Rail lengths greater than L_{max} are made up of matching rail sections mounted end to end.

Accessories and Spare Parts

Accessories for Standard Runner Blocks

Rexroth offers a broad array of accessories to cover almost all conceivable application requirements. The complete range from a single source. Optimally matched for maximum efficiency.

Accessories for standard runner blocks

Metal scraper
with spacer plates

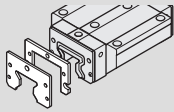

Viton or NBR wiper seals
two-piece

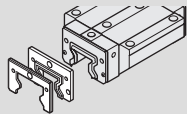

Set of Viton seals with metal scraper

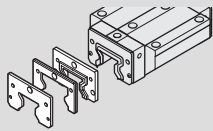

Lube plate

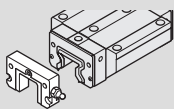

Front lube unit

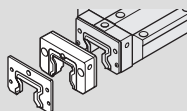

Bellows

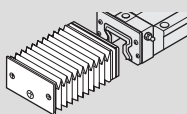

...in the appropriate dimensions
suitable for...

Standard runner blocks

Flanged, normal, standard height FNS

Steel:

R1851 ... 10

R1851 ... 13 with aluminum
end caps

R1851 ... 16 for oil and grease lubrication
from above

R1851 ... 17 for central oil lubrication systems

R1851 ... 18 for wall mounting

Resist CR¹⁾:

R1851 ... 6. (last digit same as in corresponding
steel runner block)

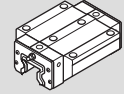

Flanged, long, standard height FLS

Steel:

R1853 ... 10

R1853 ... 13 with aluminum
end caps

R1853 ... 16 for oil and grease lubrication
from above

R1853 ... 17 for central oil lubrication systems

R1853 ... 18 for wall mounting

Resist CR¹⁾:

R1853 ... 6. (last digit same as in corresponding
steel runner block)

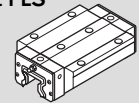

Slimline, normal, high SNH

Steel:

R1821 ... 10

R1821 ... 13 with aluminum
end caps

R1821 ... 16 for oil and grease lubrication
from above

R1821 ... 17 for central oil lubrication systems

R1821 ... 18 for wall mounting

Resist CR¹⁾:

R1821 ... 6. (last digit same as in corresponding
steel runner block)

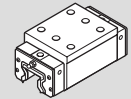

Slimline, long, high SLH

Steel:

R1824 ... 10

R1824 ... 13 with aluminum
end caps

R1824 ... 16 for oil and grease lubrication
from above

R1824 ... 17 for central oil lubrication systems

R1824 ... 18 for wall mounting

Resist CR¹⁾:

R1824 ... 6. (last digit same as in corresponding
steel runner block)

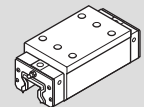

1) Corrosion-resistant runner blocks, Resist CR, matte silver hard chrome plated, replace the runner blocks with zinc-iron coating.

Accessories and Spare Parts

Accessories for Standard Runner Blocks

Metal scraper

For mounting on runner blocks for guide rails with cover strip

- 1 Metal scraper
 - Material: stainless spring steel to EN 10088
 - Version: bright
- 2 Spacer plate
 - Material: aluminum

Mounting instructions

Comes complete with spacer plate and mounting screws (the lube nipple is not included).

- When mounting the scraper, make sure there is a uniform gap between the guide rail and the scraper.

For lubricating from the end face:

- Bore open hole S_2 in the spacer plate.
- Use special lube nipple or adapter (see "Accessories").

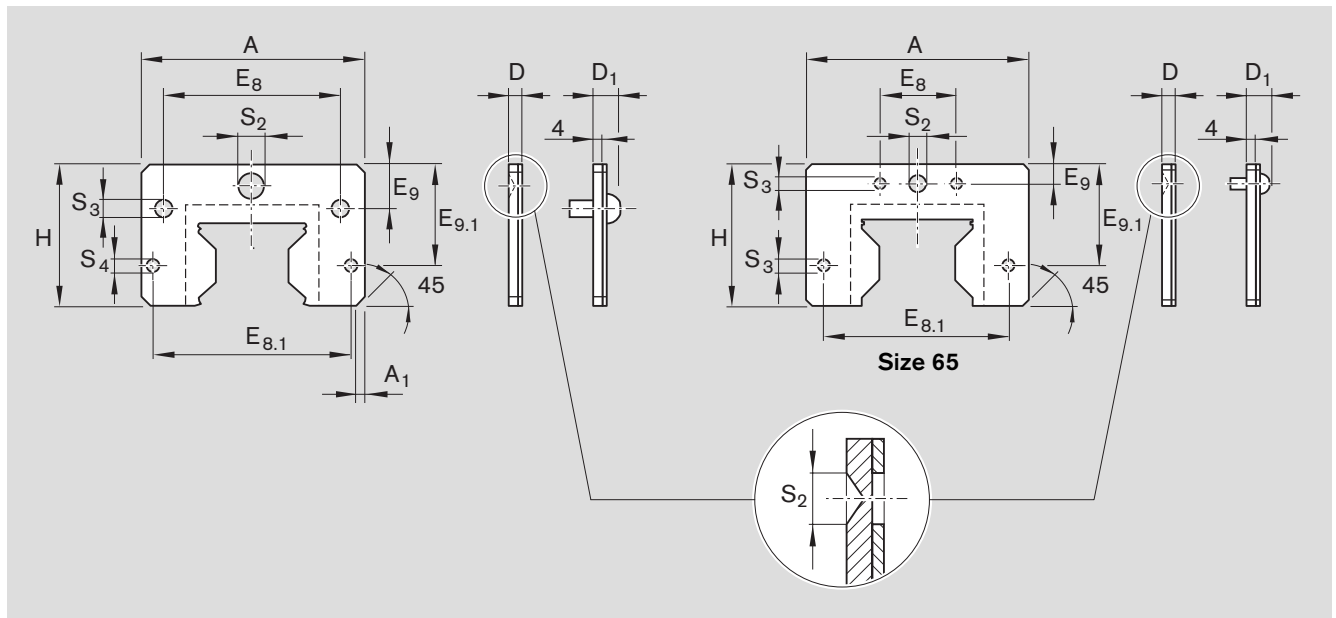
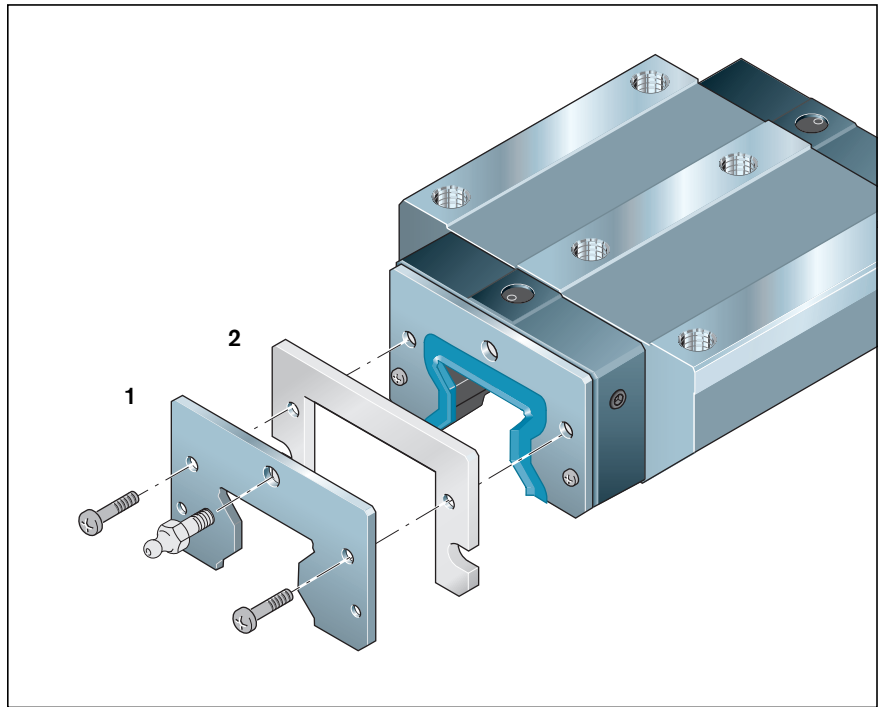

Size	Part numbers	Dimensions (mm)										Weight g		
		A	A ₁	D	D ₁	E ₈	E _{8.1}	E ₉	E _{9.1}	H	S ₂ ¹⁾		S ₃	S ₄
25 ²⁾	R1820 210 00	44.0	1.2	5	7.00	33.4	40.2	7.9	20.9	28.5	7	4	3	22
35 ³⁾	R1820 310 40	63.0	2.0	5	7.50	50.3	56.6	12.4	28.4	39.8	7	4	3	30
45 ³⁾	R1820 410 40	77.0	2.0	6	9.00	62.9	69.6	16.0	35.8	49.8	7	5	4	71
55 ³⁾	R1820 510 40	90.5	2.0	6	9.25	74.2	81.6	18.2	40.0	56.2	7	6	4	96
65 ³⁾	R1820 610 40	119.0	3.0	6	8.75	35.0	106.0	8.3	54.0	74.5	7	5	5	170

1) Rough-drilled hole in spacer plate. Bore open as required.

2) Size 25: for 0.2 mm cover strip

3) Sizes 35 to 65: for 0.3 mm cover strip

Accessories and Spare Parts

Accessories for Standard Runner Blocks

Viton or NBR wiper seals, two-piece

For mounting on runner blocks for all guide rails

- Material: stainless steel frame plus Viton or NBR seal

Special feature

Easy mounting and removal even when guide rail is screwed down. Please follow the mounting instructions!

Mounting instructions

Comes complete with mounting screws. Maximum tightening torque: 0.4 Nm

For lubricating from the end face:

- Use special lube nipple or adapter (see "Accessories").

Can be combined with an additional metal scraper. For sizes 35 to 65, use the Viton seal and metal scraper set (see next page).

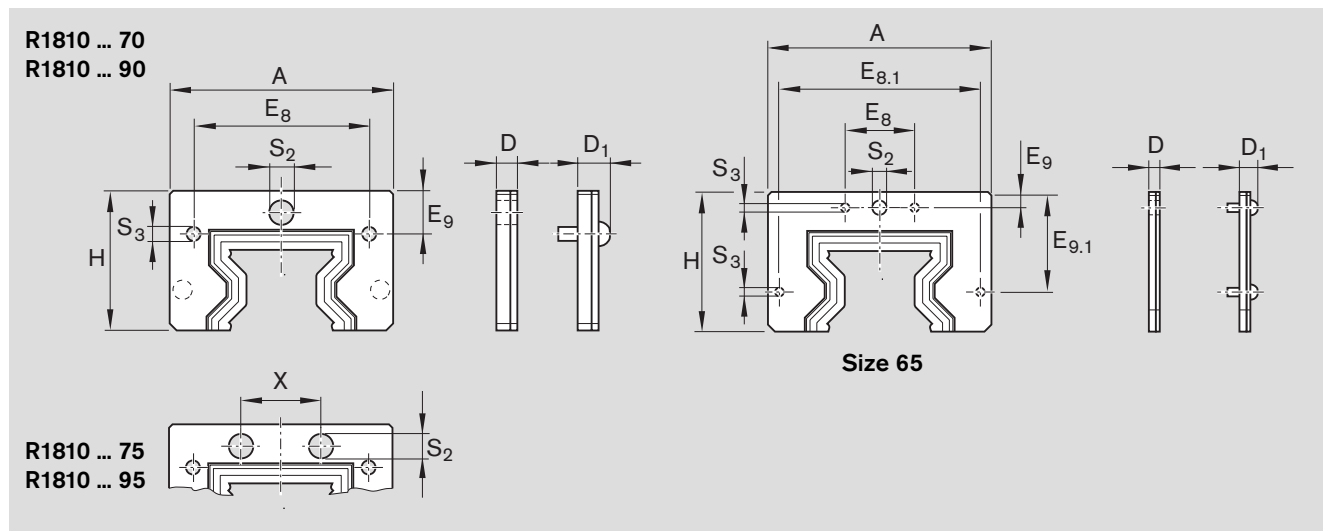
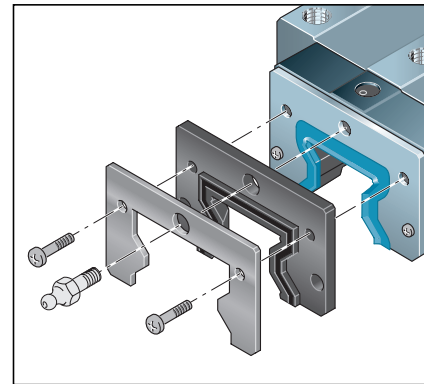

Viton seal

Size	Part numbers	Dimensions (mm)											Weight g
		A	D	D ₁	E ₈	E _{8.1}	E ₉	E _{9.1}	H	S ₂	S ₃	X ¹⁾	
25 ²⁾³⁾	R1810 200 30	44.0	6.25	8.25	33.4	–	7.75	–	29.5	–	4	–	20
35	R1810 300 70	64.0	6.00	8.50	50.3	–	12.35	–	40.0	7	4	–	40
	R1810 300 75	64.0	6.00	8.50	50.3	–	12.35	–	40.0	7	4	32	40
45	R1810 400 70	78.0	6.00	9.00	62.9	–	16.00	–	50.0	7	5	–	60
	R1810 400 75	78.0	6.00	9.00	62.9	–	16.00	–	50.0	7	5	40	60
55	R1810 500 70	91.5	6.50	9.75	74.2	–	18.20	–	57.0	7	6	–	80
	R1810 500 75	91.5	6.50	9.75	74.2	–	18.20	–	57.0	7	6	50	80
65	R1810 600 70	119.0	6.50	9.25	35.0	106	8.55	54.25	75.0	7	5	–	160

NBR seal

Size	Part numbers	Dimensions (mm)											Weight (g)
		A	D	D ₁	E ₈	E _{8.1}	E ₉	E _{9.1}	H	S ₂	S ₃	X ¹⁾	
25 ³⁾	R1810 200 90	–	–	–	–	–	–	–	–	–	–	–	–
35	R1810 300 90	64.0	6.00	8.50	50.3	–	12.35	–	40.0	7	4	–	40
	R1810 300 95	64.0	6.00	8.50	50.3	–	12.35	–	40.0	7	4	32	40
45	R1810 400 90	78.0	6.00	9.00	62.9	–	16.00	–	50.0	7	5	–	60
	R1810 400 95	78.0	6.00	9.00	62.9	–	16.00	–	50.0	7	5	40	60
55	R1810 500 90	91.5	6.50	9.75	74.2	–	18.20	–	57.0	7	6	–	80
	R1810 500 95	91.5	6.50	9.75	74.2	–	18.20	–	57.0	7	6	50	80
65	R1810 600 90	119.0	6.50	9.25	35.0	106	8.55	54.25	75.0	7	5	–	160

1) Dimension X applies only to runner blocks R18.. ... 18 or ... 68 (wall mounting).

2) Caution: Size 25 does not correspond to the drawing. Please send for the related data sheet.

3) Viton seal (R1810 200 70) and NBR seal (R1810 200 90) for size 25 in preparation

Accessories and Spare Parts

Accessories for Standard Runner Blocks

Set of Viton seal with metal scraper

For mounting on runner blocks for guide rails with cover strip

- 1 Metal scraper
- 2 Viton seal, two-piece

Mounting instructions

Comes complete with mounting screws.
Maximum tightening torque: 0.4 Nm

For lubricating from the end face:

- Use special lube nipple or adapter (see "Accessories").

Please follow the mounting instructions!

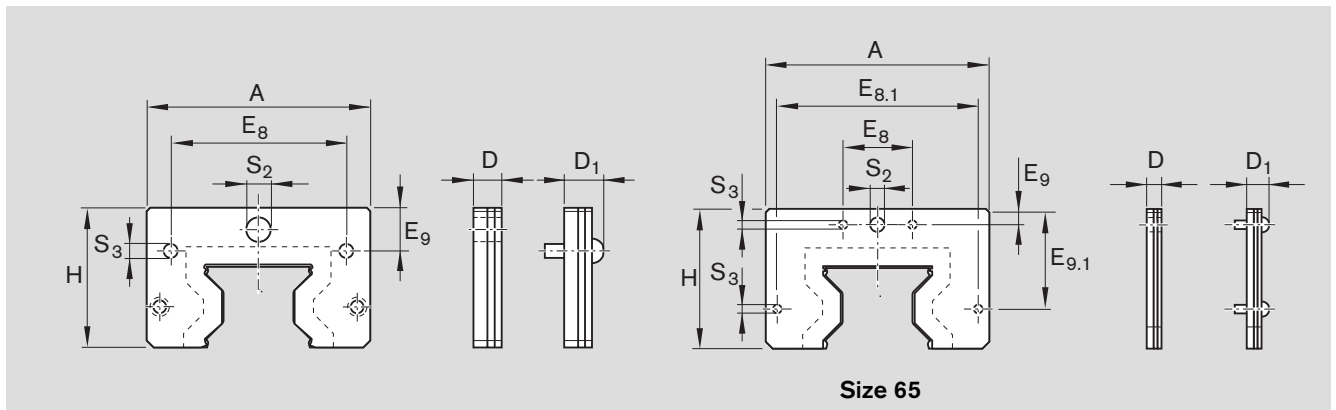
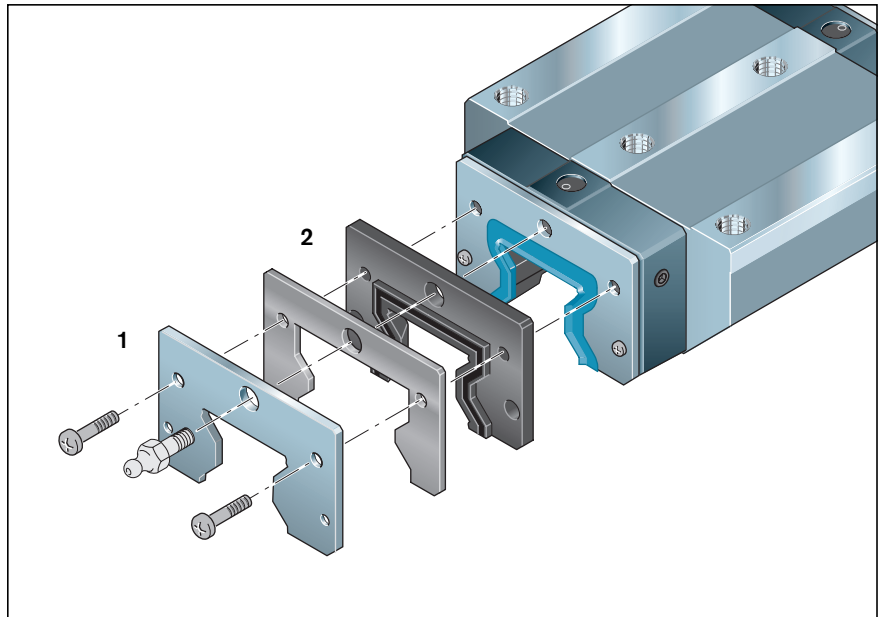

Size	Part numbers	Dimensions (mm)										Weight (g)
		A	D	D ₁	E ₈	E _{8.1}	E ₉	E _{9.1}	H	S ₂	S ₃	
35	R1810 305 70	64.0	7.0	9.50	50.3	-	12.35	-	40.0	7	4	55
45	R1810 405 70	78.0	8.0	11.00	62.9	-	16.00	-	50.0	7	5	90
55	R1810 505 70	91.5	8.5	11.75	74.2	-	18.20	-	57.0	7	6	120
65	R1810 605 70	119.0	8.5	11.25	35.0	106	8.55	54.25	75.0	7	5	240

Accessories and Spare Parts

Accessories for Standard Runner Blocks

Standard lube plate

For standard lube nipples

– Material: aluminum

Mounting instructions

Comes complete with all necessary parts for mounting to the runner block. The runner block lube nipple can be used.

- For mounting details, see “Mounting Instructions for Roller Rail Systems”.

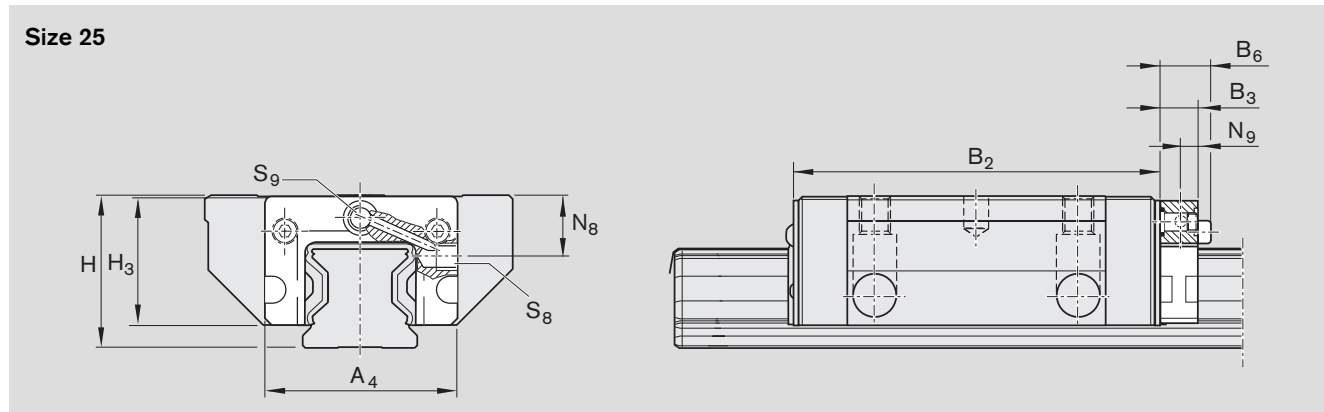
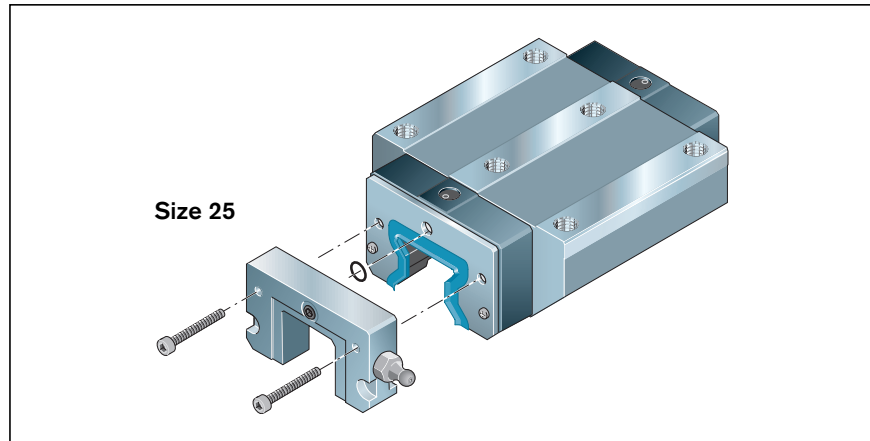

Size	Part numbers	Dimensions (mm)											Weight (g)
		A ₄	B ₃	B ₆	H ¹⁾	H ²⁾	H ₃	N ₈ ¹⁾³⁾	N ₈ ²⁾³⁾	N ₉	S ₈	S ₉	
25	R1820 211 20	44.0	12	15	36	40	28.30	14	18	6	M6	M6	32

- 1) Dimension for flanged runner blocks
- 2) Dimension for slimline runner blocks
- 3) Dimension referred to the runner block mounting face

Accessories and Spare Parts

Accessories for Standard Runner Blocks

Front lube units

For travel up to 5000 km without relubrication

Advantages during mounting and service

- Travel up to 5000 km without relubrication
- Only initial lubrication of the runner block necessary
- Front lube units at both runner block ends
- Minimal lubricant loss
- Reduced oil consumption
- No lube lines
- Max. operating temperature 60°C
- In-service refilling possible using lube nipple on end face or side
- Size 25: lube port on end face suitable for lubricating runner block with grease

For part numbers and technical data, see next page.

Size	Travel s with front lube units ¹⁾ km
25	5 000
35	5 000
45	3 000
55	2 000
65	1 000

1) Load-dependent; please refer to data and

Longer travel distances have already been reached in ongoing service life tests. For details, please consult us.

Lubricant distribution

Specially designed lube distribution ducts ensure that the lubricant is applied only where needed: directly to the raceways and to the guide rail surface.

Standard runner block with two front lube units and end seals

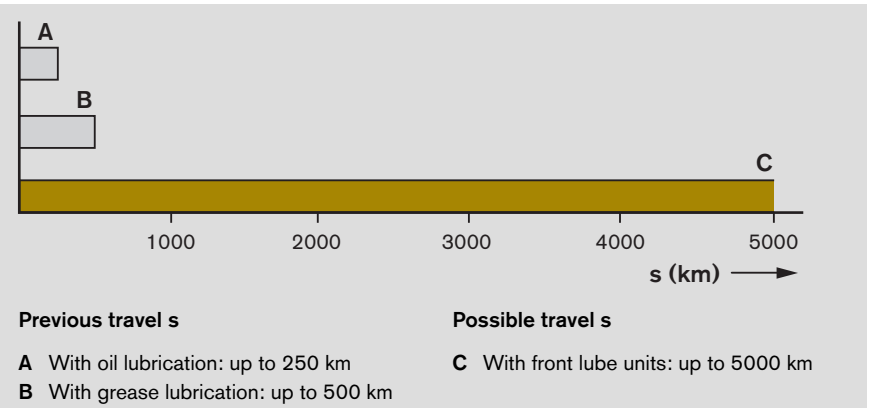
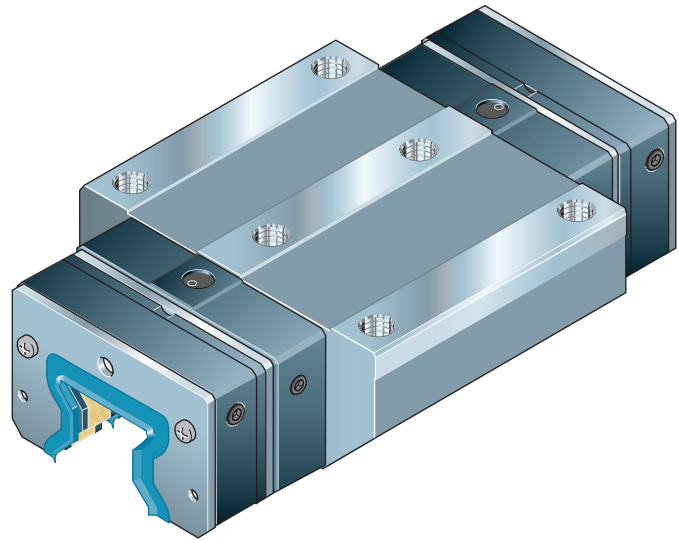

Oil consumption comparison for size 35

Front lube units	Lubricant quantity per lubrication cycle cm ³	Travel s km	Lubricant consumption	
			absolute cm ³ /km	comparative %
without	1.3	250	0.0052	100.00
with	16.6	5 000	0.0033	63.46

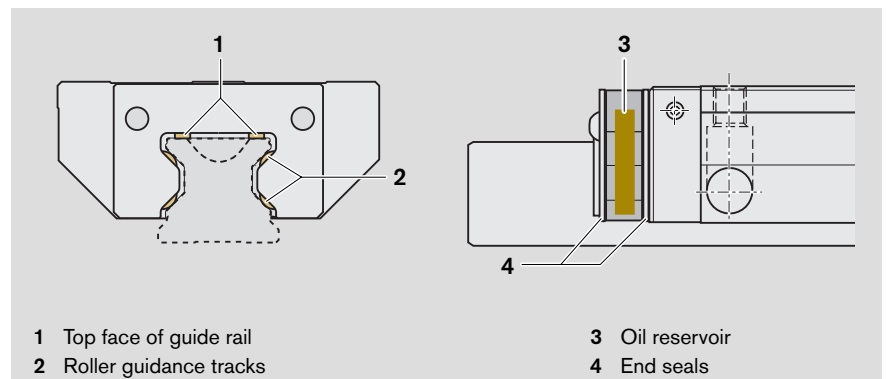

Accessories and Spare Parts

Accessories for Standard Runner Blocks

Structural design of front lube units

- 1 Front lube unit
 - Material: special plastic
- 2 End seal

Notes
 Front lube units are supplied complete with coated screws, additional end seals and lube nipple.

Front lube units with part numbers R1810 ... 00 are supplied ready-filled with oil (Mobil SHC 639) and can be mounted immediately after initial lubrication of the runner block.

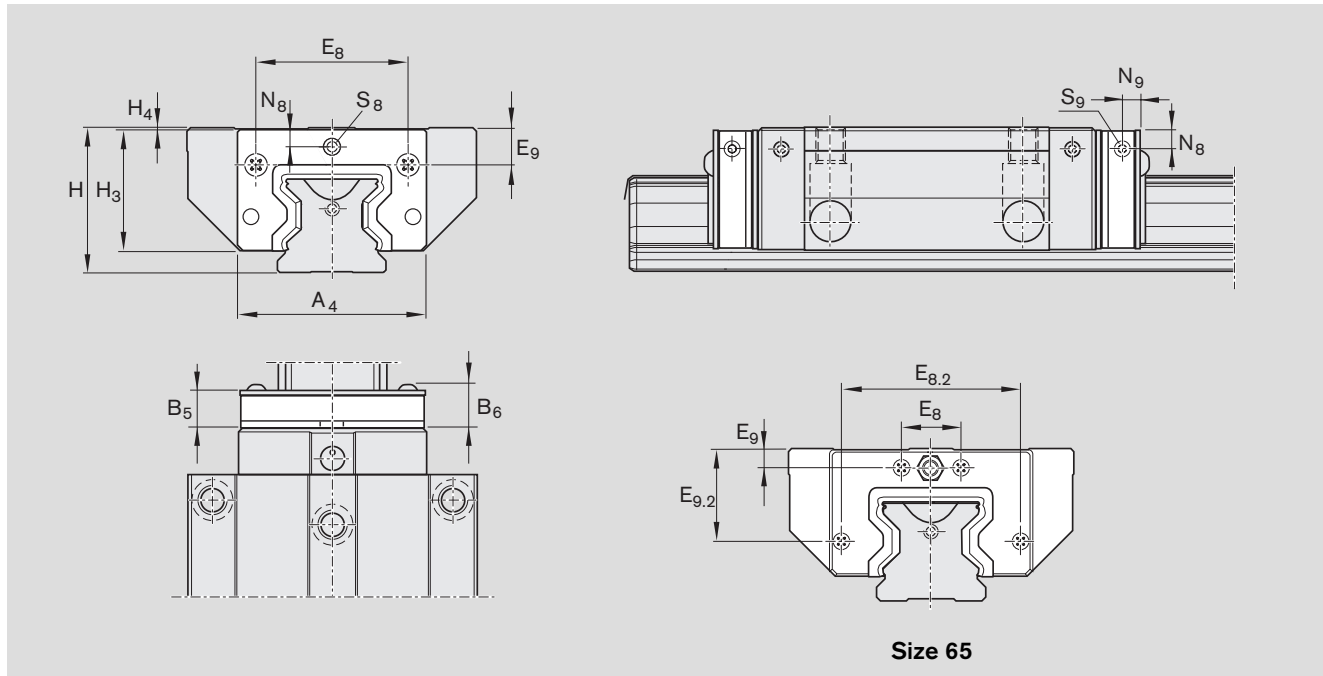
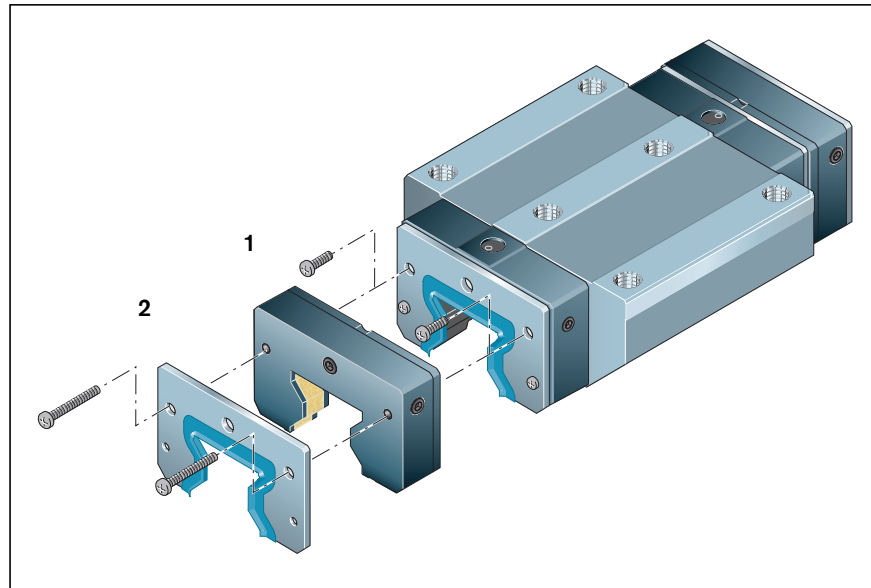

Size	Part numbers	Dimensions (mm)													Oil (cm ³)	Weight (g)	
		A ₄	B ₅	B ₆	E ₈	E _{8.2}	E ₉ ¹⁾	E _{9.2}	H ¹⁾	H ₃	H ₄ ¹⁾	N ₈ ¹⁾	N ₉	S ₈			S ₉
25	R1810 225 00	44.0	13.0	15.5	33.4	-	8.40	-	36	29.2	0.50	5.00	-	M6	-	2.6	24
35	R1810 325 00	64.0	16.5	19.0	50.3	-	13.10	-	48	40.0	0.75	6.25	5.5	M6	M6	8.3	46
						20.10 ²⁾	55 ²⁾	7.75 ²⁾	13.25 ²⁾								
45	R1810 425 00	78.0	18.5	21.8	62.9	-	16.70	-	60	50.0	0.75	7.25	7.5	M6	M6	13.8	88
						26.75 ²⁾	70 ²⁾	10.75 ²⁾	17.25 ²⁾								
55	R1810 525 00	91.5	20.3	24.3	74.2	-	18.85	-	70	56.3	0.75	8.25	9.0	M6	M6	22.8	122
						28.95 ²⁾	80 ²⁾	10.75 ²⁾	18.25 ²⁾								
65	R1810 625 00	119.0	21.0	24.3	35.0	106	9.30	55.00	90	74.8	0.75	8.55	8.5	M6	M6	47.6	225

1) Dimension referred to the runner block mounting face
 2) Dimension for high runner blocks

Initial lubrication of the runner block (basic lubrication)

⚠ Before mounting the front lube units, always lubricate the runner blocks first using grease!

Recommended grease types

- Dynalub 510
from Bosch Rexroth AG
- Castrol Longtime PD 2

⚠ If other types of grease are used, please check the compatibility of the lubricants and the possible travel!

As-supplied condition of front lube units

There are two types of front lube units:

- Part numbers R1810 ... 00
ready to mount and filled with oil (Mobil SHC 639)
- Part numbers R1810 ... 10
without lube oil filling

Initial filling of an unfilled front lube unit (Part numbers R1810 ... 10)

Recommended oil type

- Mobil SHC 639
(viscosity 1000 mm²/s at 40°C)

⚠ If other types of oil are used, please check the compatibility of the lubricants and the possible travel!

- For initial lubrication, mount one lube fitting per runner block, at either of the two end caps!

Initial lubrication is applied in three partial quantities as specified in table 1:

1. Grease the runner block with the first partial quantity as per Table 1, pressing it in slowly with the help of a grease gun.
2. Slide the runner block back and forth over at least three times the block length for three full cycles.
3. Repeat steps 1. and 2. twice more.
4. Check whether a film of lubricant is visible on the guide rail.

Size	Initial lubrication Partial quantities cm ³
25	0.8 (3x)
35	0.9 (3x)
45	1.0 (3x)
55	1.4 (3x)
65	2.7 (3x)

Table 1

- Remove the set screw from the lube hole (Fig. 1, item 1) and keep it ready for later use.
- Screw in lube nipple (2).
- Lay front lube units (3) down flat and fill with quantity of oil specified in Table 2. Leave in that position for approx. 36 hours.

- Check whether the lube insert is completely soaked with oil. Add oil, if necessary.
- Remove lube nipple.
- Screw in set screw.

Size	Oil quantity for initial filling of an unfilled front lube unit cm ³
25	See Fig. 2
35	8.3
45	14.6
55	22.8
65	47.6

Table 2

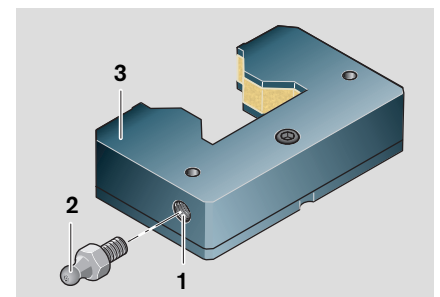

Fig. 1

- For size 25:
Stand the front lube units in oil 10 mm deep for approx. 36 hours (see Fig. 2).

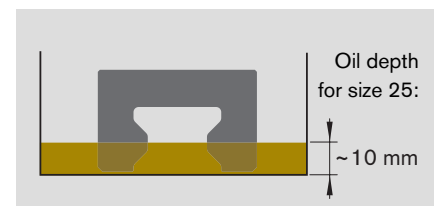

Fig. 2

Accessories and Spare Parts

Accessories for Standard Runner Blocks

Mounting instructions for front lube units

Front lube units are supplied complete with coated screws, additional end seals and lube nipple.

⚠ Mount one front lube unit at each end of the runner block (Fig. 3, item 3)!

⚠ Do not remove runner blocks from the rail!

- Remove screws (Fig. 3, item 6) – in size 65, there are four screws. Discard these screws (6)!
- If there are any end seals (7) already mounted on the runner block, leave them in place.
- Slide on the front lube units (3) and the additional end seals (5) and align them with the runner block.
- For size 25, remove the set screw (8) and insert the O-ring (9) between the runner block and the front lube units.

⚠ Mount the additional end seals (5) so that the sealing lips fit snugly all around the guide rail.

- Tighten screws (4) with tightening torque M_A (see Table 3).

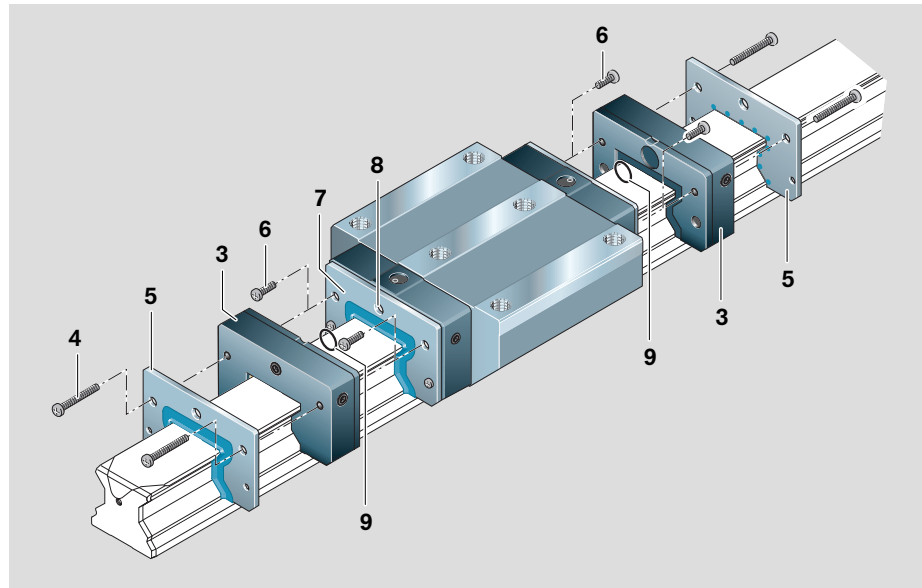

Fig. 3

Size	 Item 4	Tightening torque M_A Nm
25	M3 x 18	0.7
35	M3 x 22	0.7
45	M4 x 25	1.0
55	M5 x 30	1.3
65	M4 x 30	1.0

Table 3

In-service lubrication intervals for runner blocks with front lube units

- Check the front lubrication units when the system has covered the travel distance specified Fig. 4.

We recommend replacing the front lube units when the specified travel according to Fig. 4 has been reached or, at the latest, after 2 years. Before mounting the new front lube units, the runner block has to be relubricated with grease.

In clean operating environments, the runner blocks can be relubricated with grease (Dynalub 510; sizes 35 to 65 runner blocks can be regreased from the side and size 25 from the end):

- When the travel distance shown as the relubrication interval in Fig. 4 has been reached, apply the relubrication quantity as specified in Table 4.

Load-dependent relubrication intervals for roller runner blocks with front lube units

Sizes 25 to 65

The following conditions apply:

- Lubricants for runner blocks:
Dynalub 510 (NLGI 2 grease)
or alternatively
Castrol Longtime PD 2 (NLGI 2 grease)
- Lubricant for front lube units:
Mobil SHC 639 (synthetic oil)
- Maximum speed:
 $v_{\max} = 2 \text{ m/s}$
- No exposure to metalworking fluids
- Standard seals
- Ambient temperature:
 $T = 20 - 30^\circ\text{C}$

Size	In-service lubrication cm ³
25	0.8
35	0.9
45	1.0
55	1.4
65	2.7

Table 4

Front lube units in sizes 35 to 65 can be refilled with oil (Mobil SHC 639) through the side lube port. For the lubricant quantities, see “Initial filling of an unfilled front lube unit.”

The size 25 front lube unit **cannot** be refilled through the lube port.

⚠ If other lubricants are used, this may lead to a reduction in the relubrication intervals, the achievable travel in short-stroke applications, and the load capacities. Possible chemical interactions between the plastic materials, lubricants and preservative oils must also be taken into account.

⚠ The recommended in-service lubrication intervals depend on environmental factors, load and type of loading.

Typical environmental factors include fine metal particles, mineral and similar abraded material, solvents, and temperature. Load types include vibrations, impacts and tilting.

⚠ The service conditions are unknown to the manufacturer. Users can only determine the in-service lubrication intervals with certainty by conducting their own in-house tests or by close observation.

⚠ Do not allow the guide rails and runner blocks to come into contact with aqueous metalworking fluids!

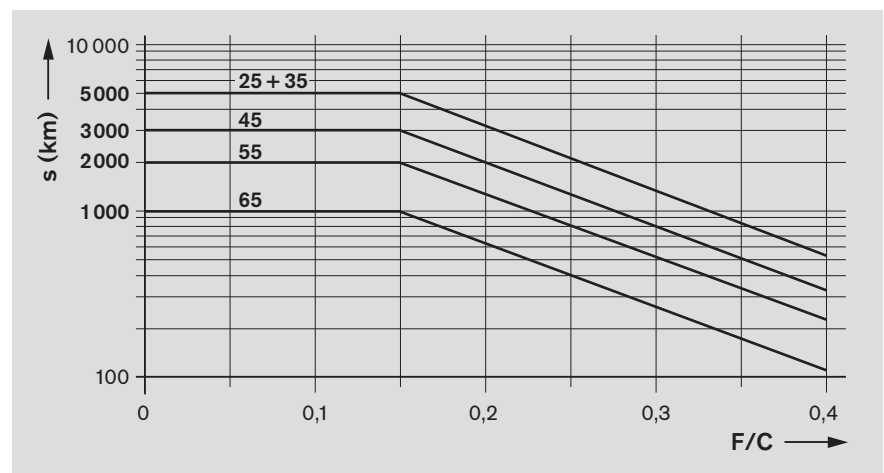

Fig. 4

Key to graph

- s = relubrication interval expressed as travel (km)
 C = dynamic load capacity (N)
 F = equivalent dynamic load (N)

Note

The load ratio F/C is the quotient of the equivalent dynamic load on the bearing F (making allowance for a preload of 8% C or 13% C) divided by the dynamic load capacity C (see “General Technical Data and Calculations”).

Accessories and Spare Parts

Accessories for Standard Runner Blocks

Protective bellows

Material: polyurethane-coated polyester fabric
 Size 25: aluminum lube plate. The runner block lube nipple can be used.

Heat resistant bellows

Material: Nomex fabric, metallized on both sides

Temperature resistance

Non combustible, non flammable
 Resistant to individual sparks, welding spatter and hot chips
 Peak temperatures of up to 200°C near the protective metal coat possible
 Operating temperature for the entire bellows: 100°C

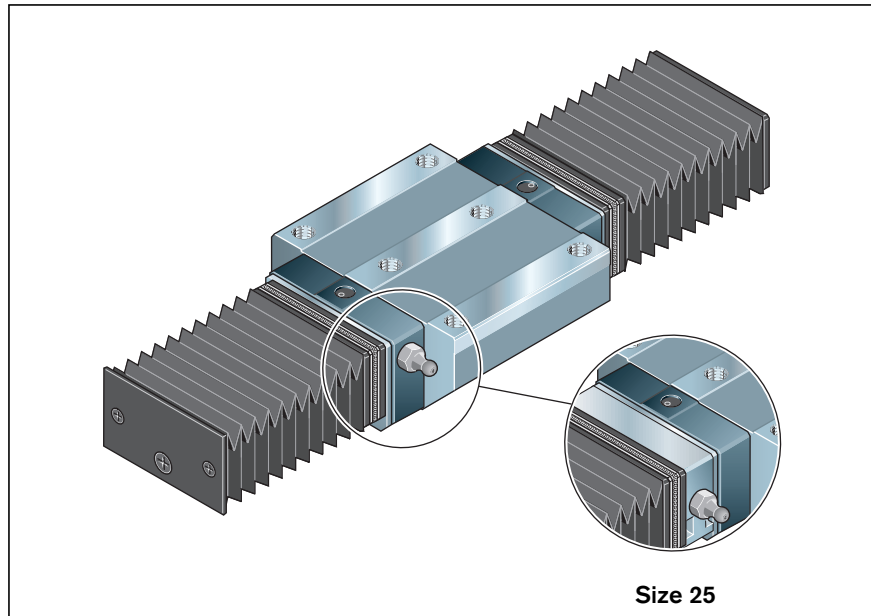

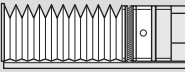
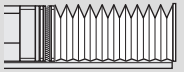
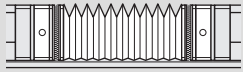
Size	 Type 1: with lube plate and end plate		 Type 2: with mounting frame and end plate		 Type 3: with 2 lube plates	
	Part number, no. of folds	Weight	Part number, no. of folds	Weight	Part number, no. of folds	Weight
	Bellows		Bellows		Bellows	
25	R1820 201 00, ...	on request	R1820 202 00, ...	on request	R1820 203 00, ...	on request
35	-	-	R1820 302 00, ...	-	-	-
45	-	-	R1820 402 00, ...	-	-	-
55	-	-	R1820 502 00, ...	-	-	-
65	-	-	R1820 602 00, ...	-	-	-
	Heat resistant bellows		Heat resistant bellows		Heat resistant bellows	
25	R1820 251 00, ...	on request	R1820 252 00, ...	on request	R1820 253 00, ...	on request
35	-	-	R1820 352 00, ...	-	-	-
45	-	-	R1820 452 00, ...	-	-	-
55	-	-	R1820 552 00, ...	-	-	-
65	-	-	R1820 652 00, ...	-	-	-

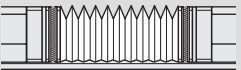
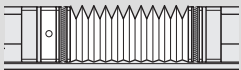
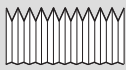
Size	 Type 4: with 2 mounting frames		 Type 5: with lube plate and mounting frame		 Type 9: bellows (spare part)	
	Part number, no. of folds	Weight	Part number, no. of folds	Weight	Part number, no. of folds	Weight
	Bellows		Bellows		Bellows	
25	R1820 204 00, ...	on request	R1820 205 00	on request	R1600 209 00	on request
35	R1820 304 00, ...	-	-	-	R1600 309 00	-
45	R1820 404 00, ...	-	-	-	R1600 409 00	-
55	R1820 504 00, ...	-	-	-	R1600 509 00	-
65	R1820 604 00, ...	-	-	-	R1600 609 00	-
	Heat resistant bellows		Heat resistant bellows		Heat resistant bellows	
25	R1820 254 00, ...	on request	R1820 255 00	on request	R1600 259 00	on request
35	R1820 354 00, ...	-	-	-	R1600 359 00	-
45	R1820 454 00, ...	-	-	-	R1600 459 00	-
55	R1820 554 00, ...	-	-	-	R1600 559 00	-
65	R1820 654 00, ...	-	-	-	R1600 659 00	-

Mounting instructions for bellows

The bellows are delivered preassembled, complete with mounting screws. The runner block lube nipple can be used.

In types 1 and 2, a tapped hole size M4, 10 mm deep and countersunk 2 x 45°, must be drilled into each end face of the rail.

See "Mounting Instructions for Bellows" for mounting.

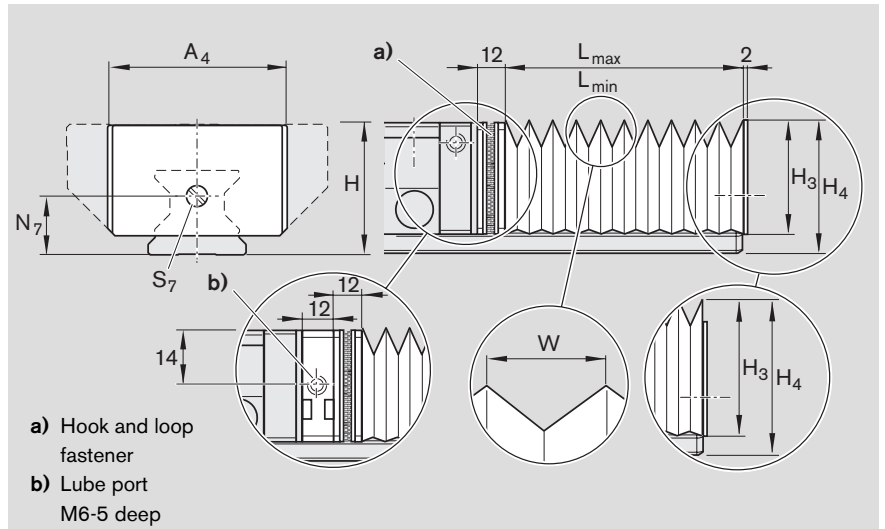

Ordering examples

Bellows

Size 35, type 2
 – Number of folds: 36

Ordering data

Part number, number of folds:
 R1820 302 00, 36 folds

Heat resistant bellows

Size 35, type 2
 – Number of folds: 36

Ordering data

Part number, number of folds:

Size	Dimensions of bellows (mm)							Factor U
	A ₄	H	H ₃	H ₄	N ₇	S ₇	W	
25	45	36	28.5	35.0	15	M4	12.9	1.32
35	64	48	39.0	47.0	22	M4	19.9	1.18
45	83	60	49.0	59.0	30	M4	26.9	1.13
55	96	70	56.0	69.0	30	M4	29.9	1.12
65	120	90	75.0	89.0	40	M4	40.4	1.08

Size	Dimensions of heat resistant bellows (mm)							Factor U
	A ₄	H	H ₃	H ₄	N ₇	S ₇	W	
25	62	36	39.0	44.5	15	M4	25.9	1.25
35	74	48	46.0	54.0	22	M4	29.9	1.21
45	88	60	54.0	64.0	30	M4	32.9	1.18
55	102	70	62.0	75.0	30	M4	37.9	1.16
65	134	90	86.0	99.0	40	M4	52.4	1.11

Bellows calculation

$$L_{max} = (\text{Stroke} + 30) \cdot U$$

$$L_{min} = L_{max} - \text{Stroke}$$

$$\text{Number of folds} = \frac{L_{max}}{W} + 2$$

L_{max} = bellows extended (mm)
 L_{min} = bellows compressed (mm)
 Stroke = stroke (mm)
 U = calculation factor
 W = maximum extension (mm)

Rail length calculation

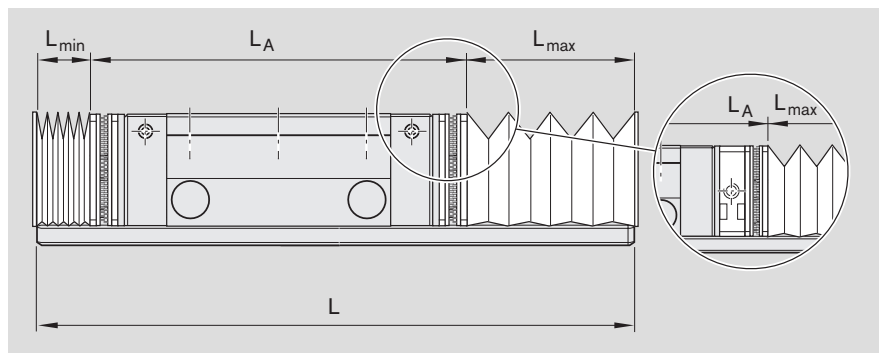

$$L = L_{min} + L_{max} + L_A$$

L = rail length (mm)
 L_A = length of runner block with mounting frame (mm)

Accessories and Spare Parts

Accessories for Standard Runner Blocks

Mounting instructions for bellows

a) Mounting the bellows to the runner block (types 2 and 4), including mounting at the rail end (types 1 and 2)

Types 1 and 2 only:

- Before mounting the bellows, drill and tap a hole in the end face of the guide rail (5), see dimensions N_7 and S_7 in the table and diagram alongside "Mounting instructions" on the previous page.

Types 2 and 4:

- If there is a lube nipple in the front lube hole (1), remove it and screw it into a lateral lube hole (relubrication side) (3).
- Use a set screw (2) to plug the open lube hole.
- Remove the upper mounting screws from the scraper plate.
- Screw the mounting frame (with hook and loop fastener (4)) to the runner block using the screws supplied along with the bellows.
- Push on the bellows.

Types 1 and 2 only:

- Once the bellows are installed, screw

b) Size 25 only:
Mounting the lube plate and the bellows (types 1, 3 and 5)

Notes

In size 25, the lube port is hidden by the bellows. Consequently, a lube plate has to be fitted to at least one end of a runner block for in-service lubrication. The lube plate can be turned round, thus allowing lubrication from the preferred side.

- Remove the lube nipple (1) or set screw (2) from the runner block (relubrication side).
- Screw the lube nipple (3) into the side of the lube plate (6).
- Insert the O-ring (7) into the recess.
- Screw the lube plate (6) and the mounting frame (4) to the runner block.
- Plug unused lube hole with a set screw.

⚠ Set screws must lie flush with the outer surface of the lube plate!

For all types:

Hook and loop fastener for the mounting frame (4)

Closing the hook and loop fastener:

- Position one edge of the hook and loop fastener part (8) on the bellows side against the mating part on the mounting frame side (4).
- Make sure the two parts are properly positioned!
- Press the bellows firmly up against the mounting frame!

Opening the hook and loop fastener:

- Using a flat tool, start at one side (preferably a corner).
- Carefully lever the two halves apart.



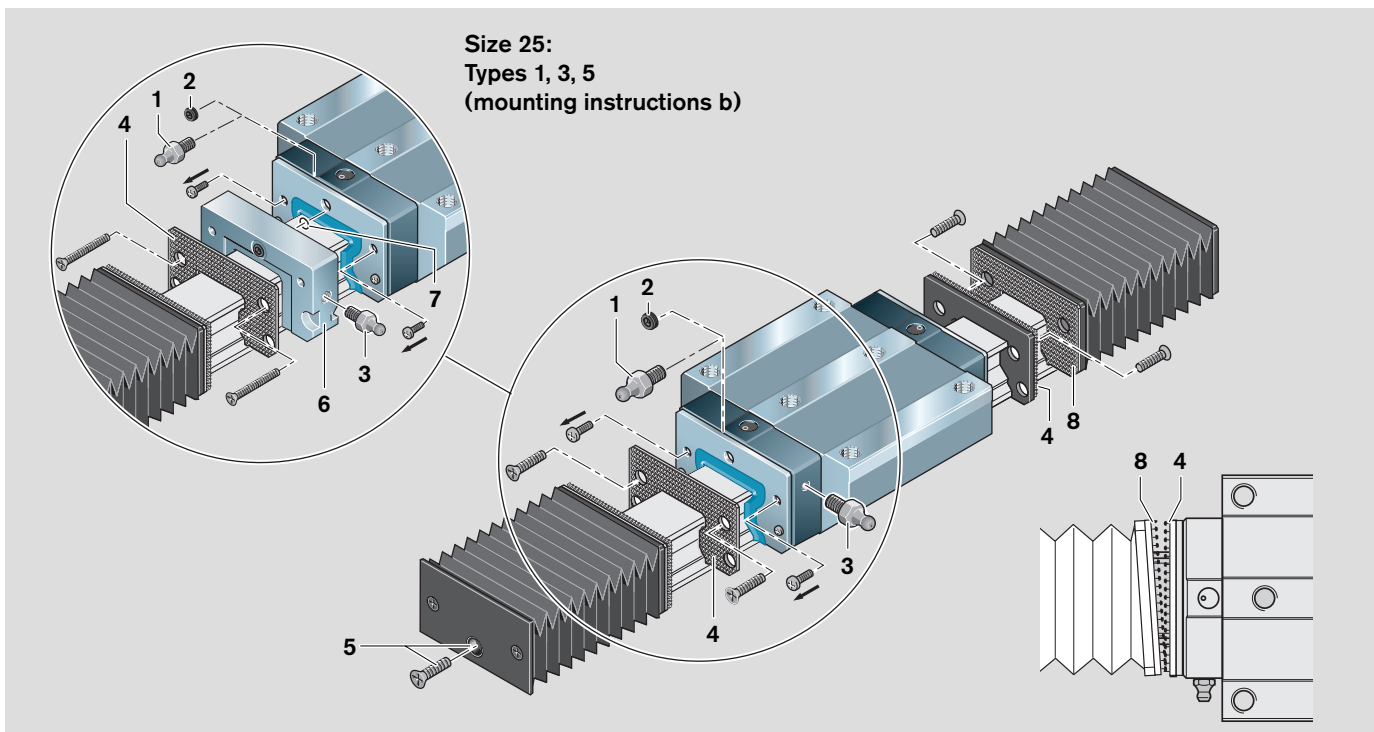

⚠ Be careful not to shear off the hooks and loops!

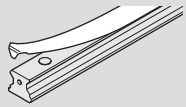
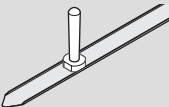
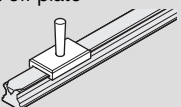
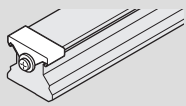
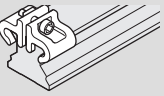

Accessories and Spare Parts

Accessories for Guide Rails

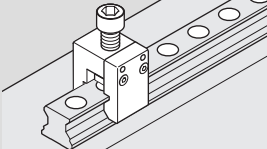
Accessories

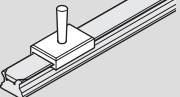
<p>Cover strip, separate</p> 
<p>Expanding tool</p> 
<p>Cover strip mounting kit With mounting tool and lift-off plate</p> 
<p>Protective end caps</p> 
<p>Strip clamps</p> 
<p>Mounting hole plugs Plastic or steel</p> 
<p>Two-piece mounting tool For steel mounting hole plugs</p> 
<p>Cover strip, separate + expanding tool</p> 
<p>Cover strip mounting kit With mounting tool and lift-off plate</p> 

...in the appropriate dimensions, suitable for...

...in the appropriate dimensions, suitable for...

Standard guide rails

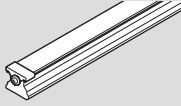
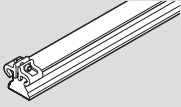
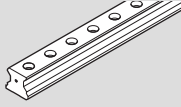
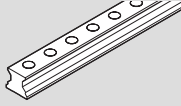
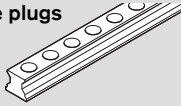
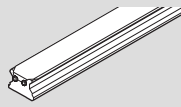
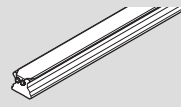
<p>For mounting from above, with cover strip and screw-down protective caps R1805 .6. .. Steel R1845 .6. .. Resist CR¹⁾</p> 
<p>For mounting from above, with cover strip and strip clamps R1805 .3. .. Steel R1845 .3. .. Resist CR¹⁾</p> 
<p>For mounting from above, for cover strip R1805 .2. .. Steel R1845 .7. .. Resist CR¹⁾</p> 
<p>For mounting from above, with plastic mounting hole plugs R1805 .5. .. Steel R1845 .0. .. Resist CR¹⁾</p> 
<p>For mounting from above, for steel mounting hole plugs R1806 .5. .. Steel R1846 .0. .. Resist CR¹⁾</p> 
<p>Wide guide rails With cover strip, screws and washers R1875 .6. .. Steel R1873 .6. .. Resist CR¹⁾</p> 
<p>Heavy duty guide rails With cover strip, screws and washers R1835 .6. .. Steel R1865 .6. .. Resist CR¹⁾</p> 

1) Corrosion-resistant guide rails, Resist CR, matte silver hard chrome plated, replace the guide rails with zinc-iron coating.

Accessories and Spare Parts

Accessories for Guide Rails

Notes on cover strip

For detailed information, see "Mounting Instructions for the Cover Strip."

Advantages

The cover strip is easy to clip on and remove.

- This considerably facilitates and speeds up the mounting process.
- The cover strip can be mounted and removed several times.

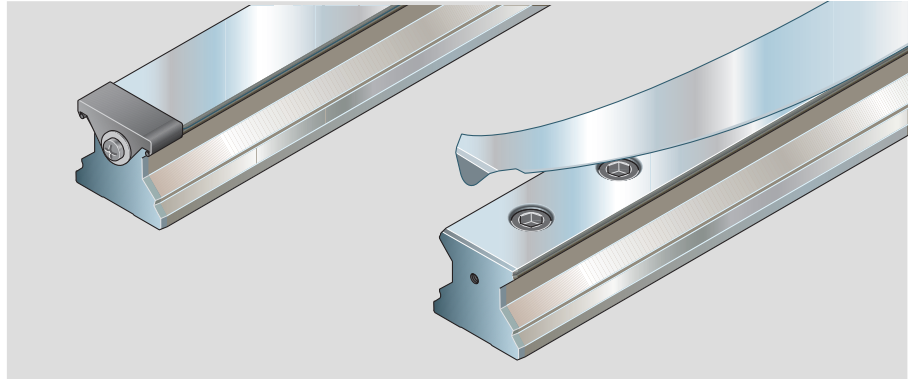

Versions and functions

A Snap-fit cover strip (standard)

- The cover strip is clipped on before the runner blocks are mounted and fits tightly.

B Sliding-fit cover strip

- For mounting or replacing a cover strip when the runner blocks or adjoining structure cannot be removed.
- A section of the snap-fit cover strip is very slightly widened and can then be easily slid under the runner blocks.

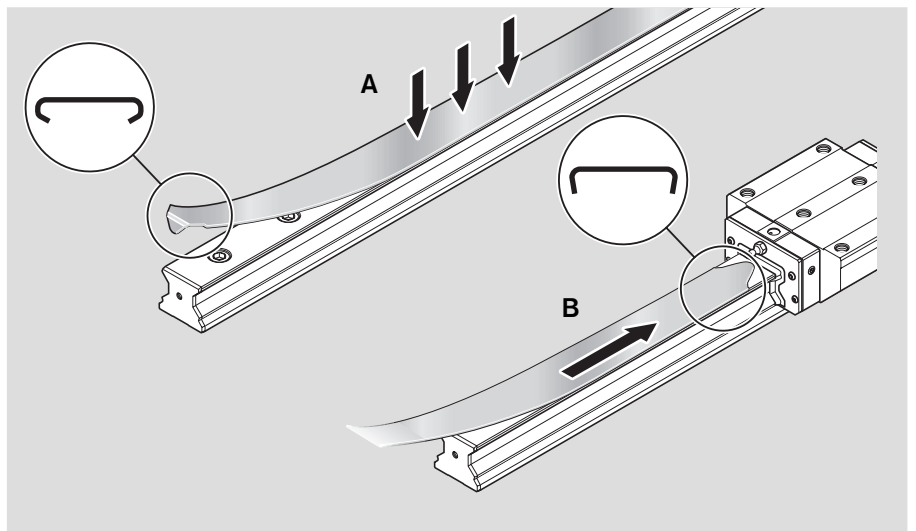

A special expanding tool can be used to create the sliding fit after a cover strip has been installed.

The main advantage is that the length L_S of the sliding fit can be optimized to suit the installation conditions.

Please read the detailed mounting instructions!

For part numbers, see the following pages.

! The cover strip is a precision-machined part that must be handled with great care. It must on no account be bent.

! Do not allow the runner blocks to travel right to the rail end! The seals on the runner blocks could be damaged by the tapered edges of the cover strip.

- Maintain a minimum distance of L_{min}

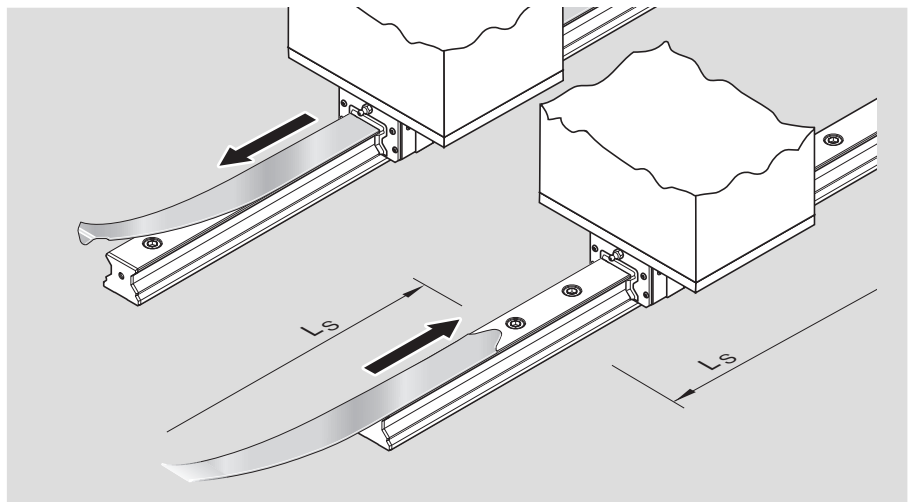

Size	L_{min} mm
25	approx. 10.0
35-65	approx. 12.0
55/85	approx. 13.0
65/100	approx. 12.5
100	approx. 12.0
125	approx. 21.5

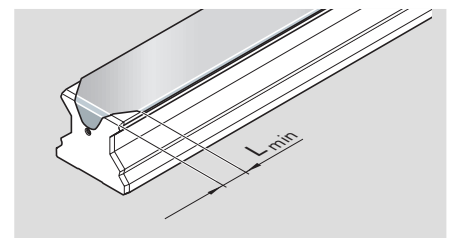

Accessories and Spare Parts

Accessories for Guide Rails

Cover strip, separate

For initial mounting, as spare part or as replacement part

Note

A matching cover strip (sliding or snap fit) can be supplied for each rail length (see previous page).

Ordering example

Standard snap-fit cover strip

- Guide rail size 35
- Rail length $L = 2696$ mm

Ordering data

Part number, length L (mm)

R1619 330 20, 2696 mm

Standard snap-fit cover strip

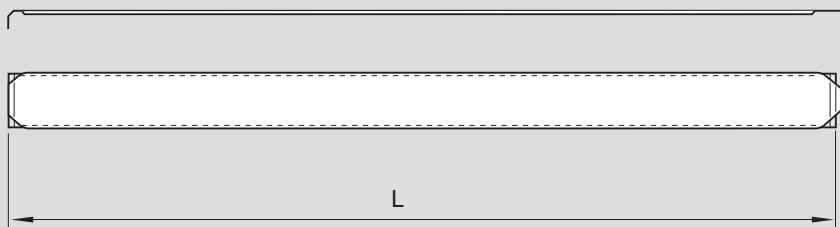

Size	Standard snap-fit cover strip Part number, length (mm)	Weight g/m
25	R1619 230 00, ...	25
35	R1619 330 20, ...	80
45	R1619 430 20, ...	100
55	R1619 530 20, ...	120
65	R1619 630 20, ...	140
55/85	R1810 532 20, ...	190
65/100	R1810 632 20, ...	220
100	R1810 231 20, ...	200
125	R1810 331 20, ...	270

Sliding-fit cover strip

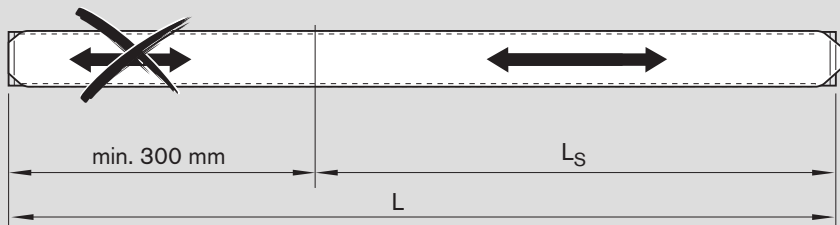

L_S = sliding fit length
 L = rail length

Ordering example

Sliding-fit cover strip

- Guide rail size 35
- Rail length $L = 2696$ mm
- Sliding fit length $L_S = 1200$ mm

Ordering data

Part number, length L (mm),

Sliding fit length L_S (mm)

R1619 330 30, 2696, 1200 mm

Size	Sliding-fit cover strip Part number, length (mm)	Weight g/m
25	R1619 230 10, ...	25
35	R1619 330 30, ...	80
45	R1619 430 30, ...	100
55	R1619 530 30, ...	120
65	R1619 630 30, ...	140
55/85	R1810 532 30, ...	190
65/100	R1810 632 30, ...	220
100	R1810 231 30, ...	200
125	R1810 331 30, ...	270

Detailed information about how to order and mount cover strips is contained in our "Mounting Instructions for the Cover Strip."

Accessories and Spare Parts

Accessories for Guide Rails

Expanding tool

For creating a sliding fit in the cover strip

Note

Detailed information about how to produce and mount sliding-fit cover strips is contained in our "Mounting Instructions for the Cover Strip."

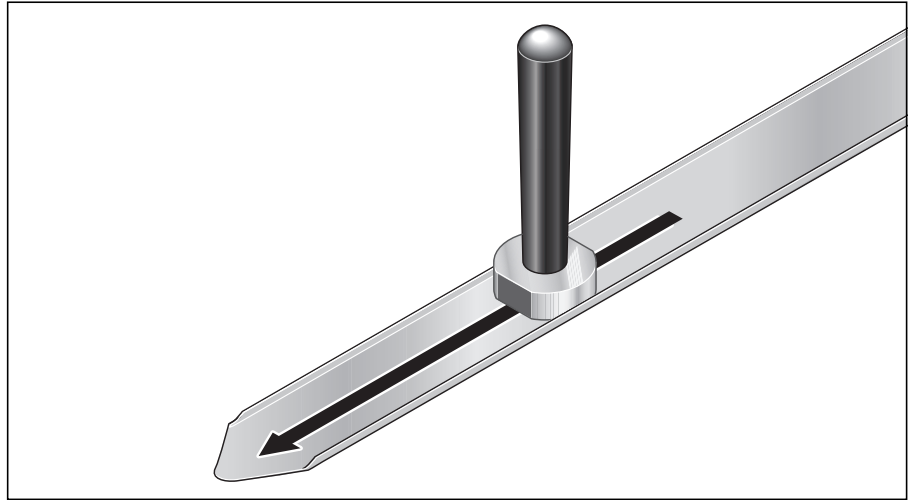

Size	Part numbers	Weight kg
25	R1619 215 10	0.08
35	R1619 315 30	0.10
45	R1619 415 30	0.13
55	R1619 515 30	0.21
65	R1619 615 30	0.27
55/85	R1810 592 30	on request
65/100	R1810 692 30	
100	R1810 291 30	
125	R1810 391 30	

Cover strip mounting kit

Mounting tool and lift-off plate

Notes

The kit comprises a mounting tool (A) for clipping on the cover strip and a lift-off plate (B) for removing the cover strip. For detailed information, see "Mounting Instructions for the Cover Strip."

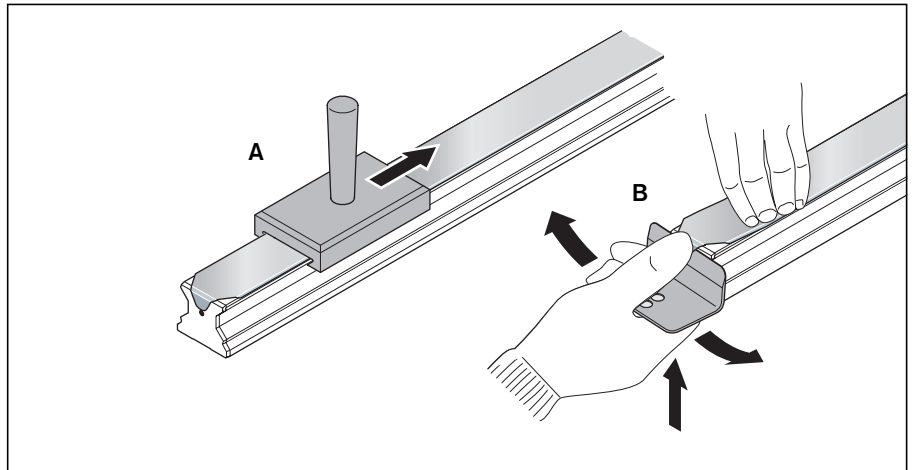

Size	Part numbers	Weight kg
25	R1619 210 70	0.17
35	R1619 310 50	0.21
45	R1619 410 50	0.20
55	R1619 510 50	0.21
65	R1619 610 50	0.28
55/85	R1810 592 53	on request
65/100	R1810 692 53	
100	R1810 291 53	
125	R1810 391 53	

Accessories and Spare Parts

Accessories for Guide Rails

Parts for securing the cover strip

Rexroth recommends securing the cover strip with:

- Protective end caps
- Screws and washers
- Strip clamps

For other means of securing the cover strip, see "Mounting Instructions for the Cover Strip."

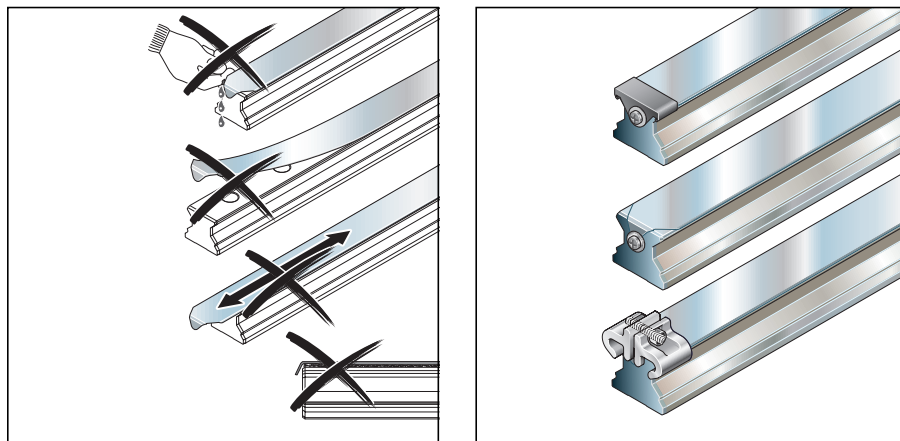

Protective end caps

Size	Single cap		Bulk pack		Set (2 pieces per unit with screws)	
	Part numbers (without screws)	Weight g	Part numbers/qty (without screws)	Weight kg	Part numbers (unit)	Weight g
25	R1619 239 00	1	R1619 239 01 / 1000	1.3	R1619 239 20	7
35	R1619 339 10	2	R1619 339 01 / 1000	2.5	R1619 339 30	10
45	R1619 439 00	4	R1619 439 01 / 700	2.6	R1619 439 20	13
55	R1619 539 00	4	R1619 539 01 / 500	2.1	R1619 539 20	20
65	R1619 639 00	6	R1619 639 01 / 300	1.7	R1619 639 20	20

Screws and washers

Size	Screws (1200 per unit)		Washers (1200 per unit)	
	Part numbers (unit)	Weight kg	Part numbers (unit)	Weight kg
25	R3427 046 05	1.8	R3448 026 01	0.92
35	R3427 046 05	1.8	R3448 024 01	1.30
45	R3427 046 05	1.8	R3448 024 01	1.30
55	R3427 046 05	1.8	R3448 027 01	2.90
65	R3427 046 05	1.8	R3448 027 01	2.90
55/85	R3427 046 05	1.8	R3448 027 01	2.90
65/100	R3427 046 05	1.8	R3448 027 01	2.90
100	R3427 046 05	1.8	R3448 027 01	2.90
125	R3427 046 05	1.8	R3448 027 01	2.90

Strip clamps

Size	Set (2 pieces per unit)		Bulk pack (100 per unit)	
	Part numbers (unit)	Weight g	Part numbers (unit)	Weight kg
25	R1619 239 50	14	R1619 239 60	1.4
35	R1619 339 50	38	R1619 339 60	3.8
45	R1619 439 50	56	R1619 439 60	5.6
55	R1619 539 50	62	R1619 539 60	6.2
65	R1619 639 50	84	R1619 639 60	8.4

Accessories and Spare Parts

Accessories for Guide Rails

Plastic mounting hole plugs

Size	Single plug		Bulk pack	
	Part numbers	Weight (g)	Part numbers/qty ¹⁾	Weight (g)
25	R1605 200 80	0.3	R1605 200 80 / 5000	1.2
35	R1605 300 80	0.6	R1605 300 80 / 2000	1.2
45	R1605 400 90	1.0	R1605 400 80 / 1000	1.0
55	R1605 500 90	1.7	R1605 500 80 / 500	0.8
65	R1605 600 90	2.1	–	–

1) When ordering bulk packs, add the required quantity to the part number of the single plug.

Mounting instructions

For details on how to mount the plastic plugs, see "Mounting Instructions for Roller Rail Systems."

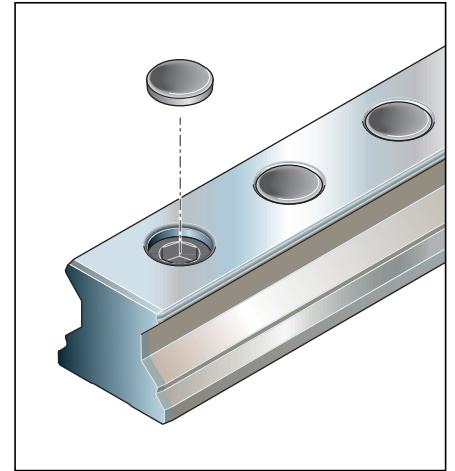

Steel mounting hole plugs

Size	Single plug made of machining steel		Single plug, Resist NR II ¹⁾	
	Part numbers	Weight (g)	Part numbers	Weight (g)
25	R1606 200 75	2	on request	on request
35	R1606 300 75	3		
45	R1606 400 75	6	R1606 400 78	6
55	R1606 500 75	8	R1606 500 78	8
65	R1606 600 75	9	R1606 600 78	9

1) Single plug, Resist NR II made from corrosion-resistant steel 1.4305

Notes on delivery and mounting

Steel mounting hole plugs are not supplied with the guide rails.

Order the mounting tool along with the plugs!

For details on how to mount the steel plugs, see "Mounting Instructions for Roller Rail Systems."

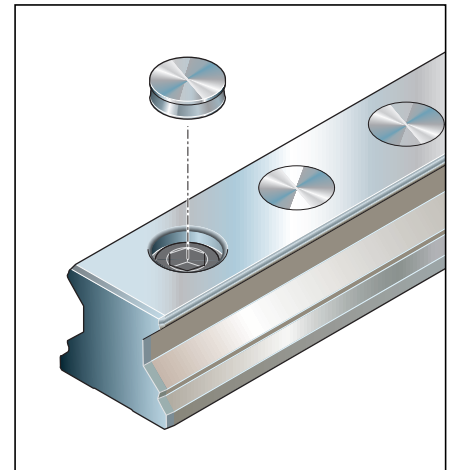

Mounting tool for steel mounting hole plugs

Two-piece

Notes

A mounting tool with mounting instructions is available for fitting steel mounting hole plugs.

The two-piece mounting tool is suitable for fitting plugs to a screwed down guide rail.

Size	Part numbers	Weight (kg)
25	R1619 210 20 ¹⁾	0.37
35	R1619 310 30	0.57
45	R1619 410 30	0.85
55	R1619 510 30	1.50
65	R1619 610 30	1.85

1) One-piece; two-piece on request

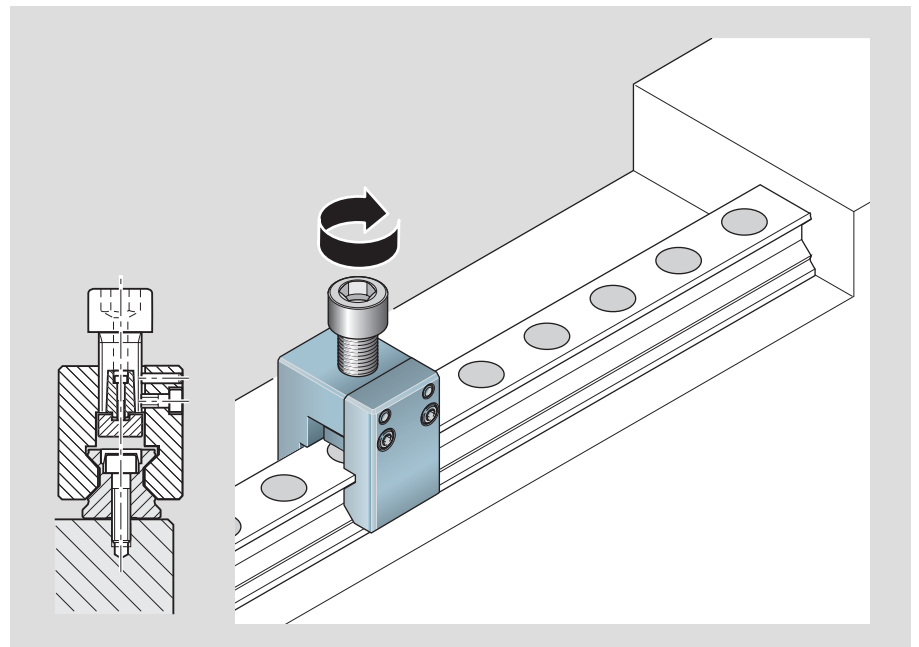

Accessories and Spare Parts

General Accessories – Runner Blocks

General accessories for runner blocks

Lube nipples



Lube fittings



- Reducers
- Extension pieces
- Connectors
- Swivel fittings
- Tube connectors

O-rings

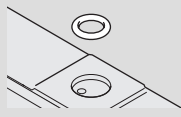

Mounting aid
For heavy duty runner blocks

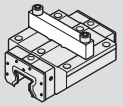
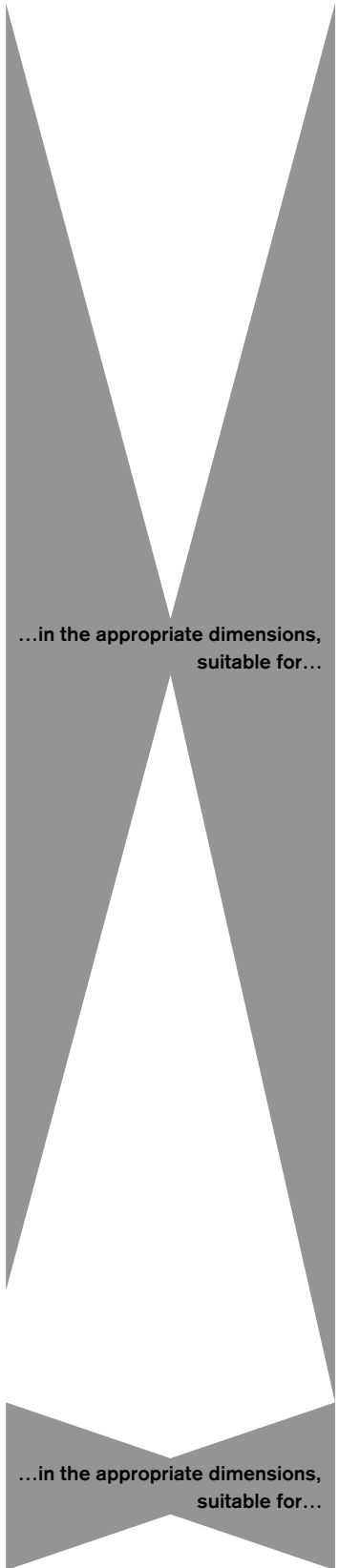

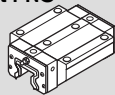

Standard runner blocks

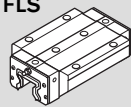
Flanged, normal, standard height FNS
Steel:
R1851 ... 10 
R1851 ... 13 with Al end caps
R1851 ... 16 for oil/grease lubrication from above
R1851 ... 17 for central oil lubrication systems
R1851 ... 18 for wall mounting
Resist CR¹⁾:
R1851 ... 6. (last digit same as in corresponding steel runner block)

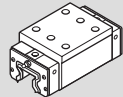
Flanged, long, standard height FLS
Steel:
R1853 ... 10 
R1853 ... 13 with Al end caps
R1853 ... 16 for oil/grease lubrication from above
R1853 ... 17 for central oil lubrication systems
R1853 ... 18 for wall mounting
Resist CR¹⁾:
R1853 ... 6. (last digit same as in corresponding steel runner block)

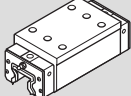
Slimline, normal, high SNH
Steel:
R1821 ... 10 
R1821 ... 13 with Al end caps
R1821 ... 16 for oil/grease lubrication from above
R1821 ... 17 for central oil lubrication systems
R1821 ... 18 for wall mounting
Resist CR¹⁾:
R1821 ... 6. (last digit same as in corresponding steel runner block)

Slimline, long, high SLH
Steel:
R1824 ... 10 
R1824 ... 13 with Al end caps
R1824 ... 16 for oil/grease lubrication from above
R1824 ... 17 for central oil lubrication systems
R1824 ... 18 for wall mounting
Resist CR¹⁾:
R1824 ... 6. (last digit same as in corresponding steel runner block)

Wide runner blocks
Wide, long, standard height BLS
R1872 ... 10 Steel 
R1872 ... 60 Resist CR¹⁾

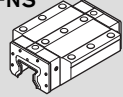
Heavy duty runner blocks
Flanged, normal, stand. height FNS
R1861 ... 10 Steel 
R1861 ... 60 Resist CR¹⁾

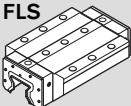
Flanged, long, standard height FLS
R1863 ... 10 Steel 
R1863 ... 60 Resist CR¹⁾

1) Corrosion-resistant runner blocks, Resist CR, matte silver hard chrome plated, replace the runner blocks with zinc-iron coating.

Accessories and Spare Parts

General Accessories – Runner Blocks

Lube nipples

Hydraulic type lube nipple

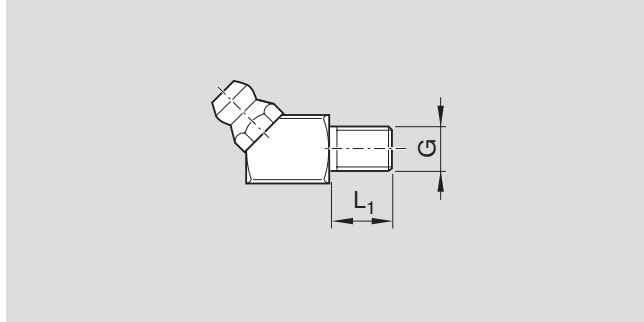

Part numbers	Dimensions (mm)		Weight g
	G	L ₁	
R3417 007 02	M6	8	7.4
R3417 010 02	M8x1	10	7.8

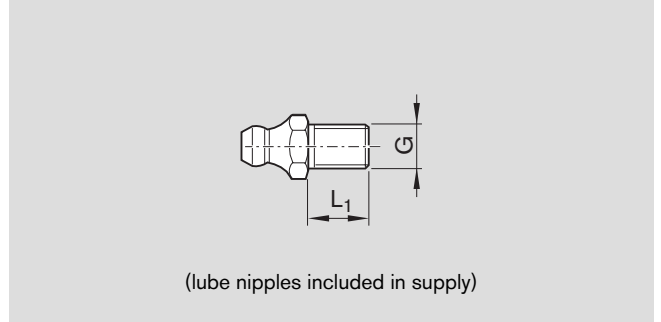

Part numbers	Dimensions (mm)		Weight g
	G	L ₁	
R3417 008 02	M6	8	2.6
R3417 014 02	M8x1	10	4.5

Lube fittings

Reducers

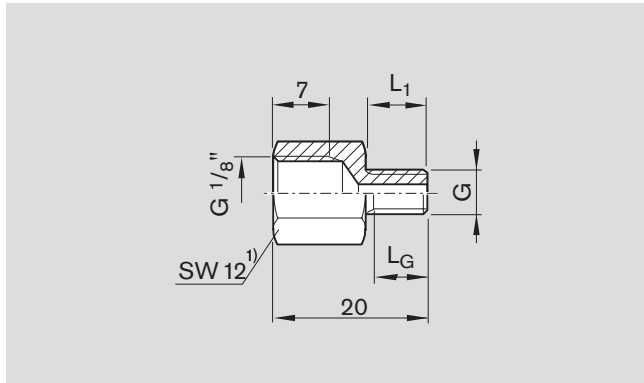

Part numbers	Dimensions (mm)			Weight g
	G	L ₁	L _G	
R3455 030 34	M6	8	6.5	7.5
R3455 030 51	M8x1	8	6.5	8.6

1) SW = WAF (width across flats)

Extension pieces

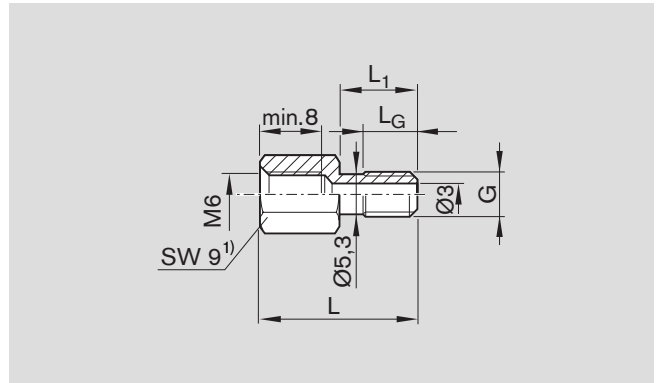

Part numbers	Dimensions (mm)				Weight g
	G	L	L ₁	L _G	
R3455 030 69	M6	21.0	10.5	7	5.0
R3455 030 87	M6	25.0	14.5	8	5.5
R3455 030 85	M6	26.5	16.0	7	5.0

General Accessories – Runner Blocks

Connectors

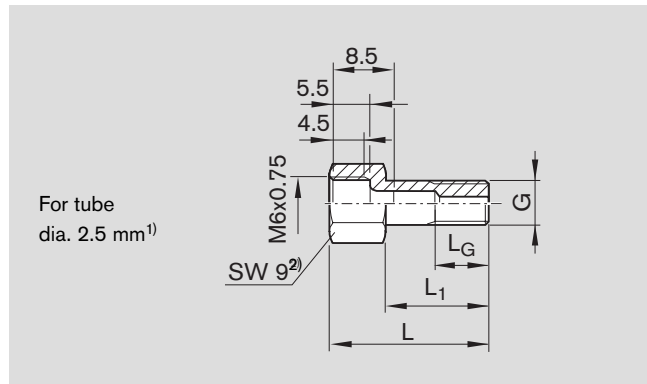

Part numbers	Dimensions (mm)				Weight g
	G	L	L ₁	L _G	
R3455 030 38	M6	15.5	8.0	6.5	4.1
R3455 030 92	M6	17.3	9.8	7.5	5.0
R3455 030 90	M6	20.0	12.5	8.0	5.0
R3455 030 50	M6	22.0	14.5	8.0	5.2
R3455 030 89	M6	24.0	16.5	8.0	5.0

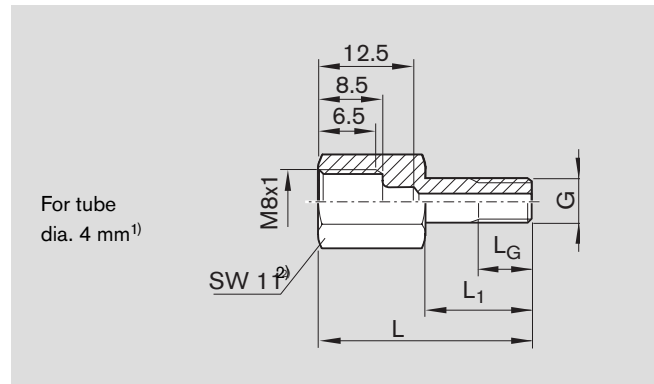

Part numbers	Dimensions (mm)				Weight g
	G	L	L ₁	L _G	
R3455 030 37	M6	22.0	8.0	6.5	8.8
R3455 030 79	M6	23.8	9.8	7.5	10.0
R3455 030 88	M6	28.5	14.5	8.0	10.0
R3455 030 52	M6	30.0	16.0	8.0	10.4

- 1) For connections as per DIN 3854 and DIN 3862 (solderless tube fittings)
- 2) SW = WAF (width across flats)

Swivel fittings

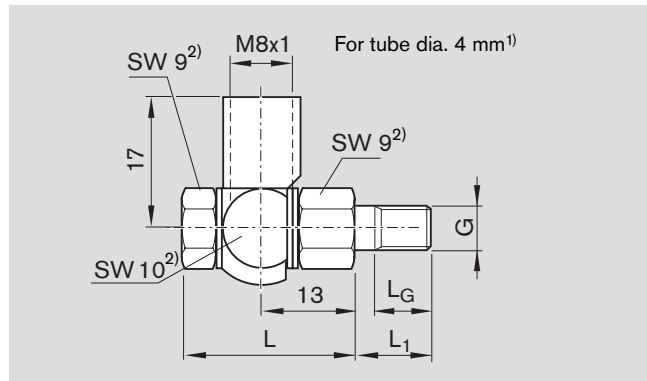

Part numbers	Dimensions (mm)				Weight g
	G	L	L ₁	L _G	
R3417 018 09	M6	22	8.0	6.5	17.5
R3417 045 09	M6	22	9.8	7.5	17.0
R3417 044 09	M6	22	12.5	8.0	20.0
R3417 023 09	M6	22	14.5	8.0	18.8
R3417 043 09	M6	22	16.5	8.0	20.0

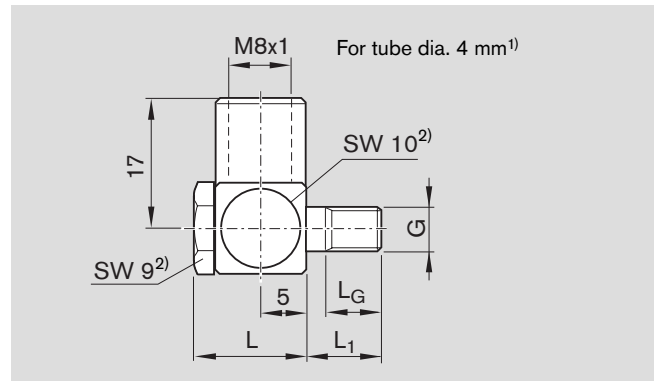

Part numbers	Dimensions (mm)				Weight g
	G	L	L ₁	L _G	
R3417 047 09	M6	12	8.0	8.0	10
R3417 048 09	M6	12	9.8	8.5	10

- 1) For connections as per DIN 3854 and DIN 3862 (solderless tube fittings)
- 2) SW = WAF (width across flats)

Accessories and Spare Parts

General Accessories – Runner Blocks

Tube connectors

Tube materials

- Copper
- Brass
- PU
- Nylon

Straight connector

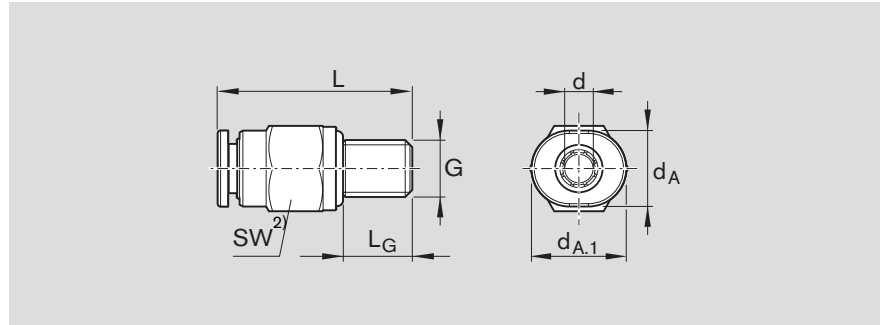

Part numbers	Dimensions (mm)							Weight g
	d_A	$d_{A,1}$	$d^{1)}$	G	L	L_G	WAF	
R3417 035 09	8.5	10	4	M6	20.5	8	9	4.6
R3417 036 09	10.0	12	6	M6	21.5	8	10	4.8

1) Tube diameter

2) SW = WAF (width across flats)

Angled socket connector, rotatable¹⁾

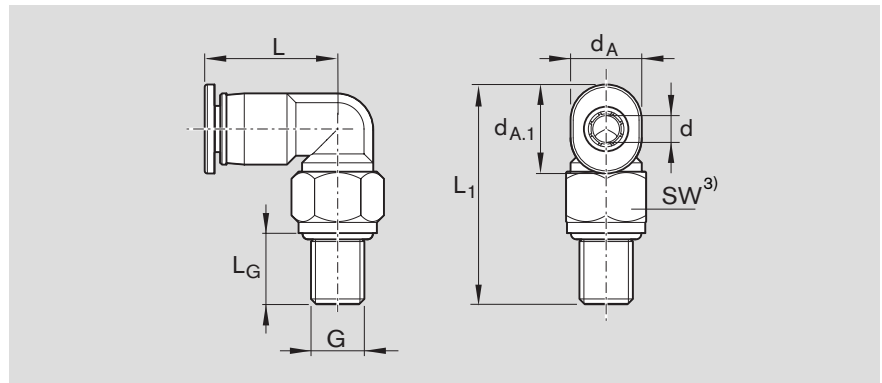

Part numbers	Dimensions (mm)							Weight g	
	d_A	$d_{A,1}$	$d^{2)}$	G	L	L_1	L_G		WAF
R3417 038 09	8.0	10	4	M6	14.95	24.7	8	9	5.1
R3417 039 09	10.5	12	6	M6	15.90	24.9	8	9	6.1

1) Maximum lubricating pressure: 30 bar (exerting slow pressure with manual grease gun)

2) Tube diameter

3) SW = WAF (width across flats)

O-rings



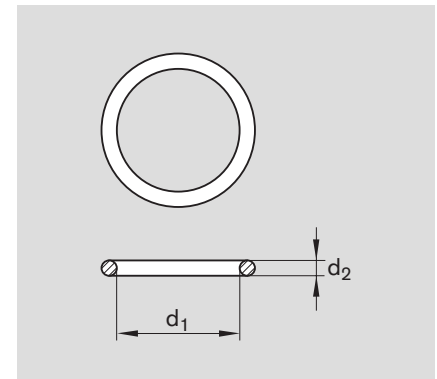



Part numbers	$d_1 \times d_2$ mm	Weight g
R3411 128 01	4 x 1.5	0.03
R3411 108 01	5 x 1.5	0.04
R3411 136 01	6 x 1.0	0.02
R3411 004 01	6 x 2.0	0.09
R3411 122 01	7 x 1.5	0.06
R3411 008 01	8 x 2.0	0.12
R3411 135 01	10 x 1.5	0.08
R3411 018 01	12 x 1.5	0.09
R3411 145 01	15 x 2.5	0.34



Accessories and Spare Parts

General Accessories – Runner Blocks

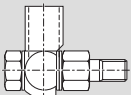
Combination options for lube fittings

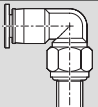
Hydraulic type lube nipple		R3417 007 02 R3417 008 02 M6x8 long					
Reducers		R3455 030 34 M6x8 to G 1/8					
Extension pieces					R3455 030 87 M6x14.5 to M6		
Connectors		R3455 030 38 M6x8 to M6x0.75 for tube dia. 2.5	R3455 030 92 M6x9.8 to M6x0.75 for tube dia. 2.5	R3455 030 90 M6x12.5 to M6x0.75 for tube dia. 2.5	R3455 030 50 M6x14.5 to M6x0.75 for tube dia. 2.5	R3455 030 89 M6x16.5 to M6x0.75 for tube dia. 2.5	
Swivel fittings							
Straight connector							
Angled socket connector, rotatable							

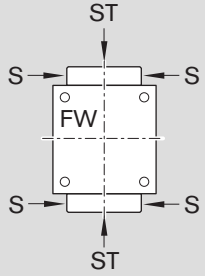
Roller runner blocks		Version	Size					
	Standard RB	25	ST	-	-	-	-	
		35	S, ST	-	-	-	-	
		45	S, ST ¹⁾	ST ²⁾	-	-	-	
		55	S, ST ¹⁾	ST ²⁾	-	-	-	
		65	S, ST ¹⁾	ST	-	-	-	
	Wide RB	55/85	S, ST	-	-	-	-	
		65/100	S, ST	ST	-	-	-	
	Heavy duty RB	100	-	-	-	-	-	
		125	-	-	-	-	-	
	Standard RB with metal scraper R1820 .10 00 or ... 40	25	-	-	ST	-	-	
		35	S	-	ST	-	-	
		45	S	-	-	ST ³⁾	-	
		55	S	-	-	ST ³⁾	-	
		65	S	-	-	ST	-	
	Standard RB with Viton seal R1810 .00 30/40/70/75 or NBR seal R1810 .00 90/95	25	-	-	-	ST	-	
		35	S	-	-	ST ³⁾	-	
		45	S	-	-	ST ³⁾	-	
		55	S	-	-	ST	-	
	Standard RB with Viton/NBR seal R1810 .00 70/75/90/95 and metal scraper R1820 .10 40 or Viton seal/metal scraper set R1810 .05 70	25	-	-	-	-	-	
		35	S	-	-	ST	-	
45		S	-	-	-	ST ³⁾		
55		S	-	-	-	ST		
	65	S	-	-	-	ST		

S = Connection at side of runner block (RB) end cap
ST = Connection at end face of runner block (RB) end cap

							R3417 010 02	R3417 014 02
							M8x1x10	
							R3455 030 51	M8x1x8 to G 1/8
						R3455 030 85		
						M6x16 to M6		
		R3455 030 37	R3455 030 79		R3455 030 88	R3455 030 52		
		M6x8 to M8x1 for tube dia. 4	M6x9.8 to M8x1 for tube dia. 4		M6x14.5 to M8x1 for tube dia. 4	M6x16 to M8x1 for tube dia. 4		
		R3417 018 09	R3417 045 09	R3417 044 09	R3417 023 09		R3417 043 09	
		R3417 047 09	R3417 048 09	M6x12.5 to M8x1 for tube dia. 4	M6x14.5 to M8x1 for tube dia. 4		M6x16.5 to M8x1 for tube dia. 4	
		M6x8 to M8x1 for tube dia. 4	M6x9.8 to M8x1 for tube dia. 4					
		R3417 035 09						
		R3417 036 09						
		M6x8 for tube dia. 4 and 6						
		R3417 038 09						
		R3417 039 09						
		M6x8 for tube dia. 4 and 6						
	Roller runner blocks							
	Size							
	25	ST	-	-	-	-	-	
	35	S, ST	-	-	-	-	-	
	45	S, ST ¹⁾	ST ²⁾	-	-	-	-	
	55	S, ST ¹⁾	ST ²⁾	-	-	-	-	
	65	S, ST ¹⁾	ST	-	-	-	-	
	55/85	S, ST	-	-	-	-	-	
	65/100	S, ST	ST	-	-	-	-	
	100	-	-	-	-	-	S, ST	
	125	-	-	-	-	-	S, ST	
	25	-	-	ST	-	-	-	
	35	S	-	ST	-	-	-	
	45	S	-	-	ST ³⁾	-	-	
	55	S	-	-	ST ³⁾	-	-	
	65	S	-	-	ST	-	-	
	25	-	-	-	ST	-	-	
	35	S	-	-	ST ³⁾	-	-	
	45	S	-	-	ST ³⁾	-	-	
	55	S	-	-	(ST)	ST ²⁾	-	
	65	S	-	-	(ST)	ST	-	
	25	-	-	-	-	-	-	
	35	S	-	-	ST	-	-	
	45	S	-	-	-	ST	ST ³⁾	
	55	S	-	-	-	ST	ST	
	65	S	-	-	-	ST	ST	

1) Preferred M6x9.8

2) Not for runner blocks R18... 13

3) For runner blocks R18... 13 with aluminum end caps, reduce the screwed-in length (using a 0.5 mm washer)

Accessories and Spare Parts

General Accessories – Runner Blocks

Mounting aid for heavy duty runner blocks

Note

For size 125:

The mounting aid expands the runner block elastically, making it easier to slide it onto the guide rail.

Bolts M27x100 not included in supply.

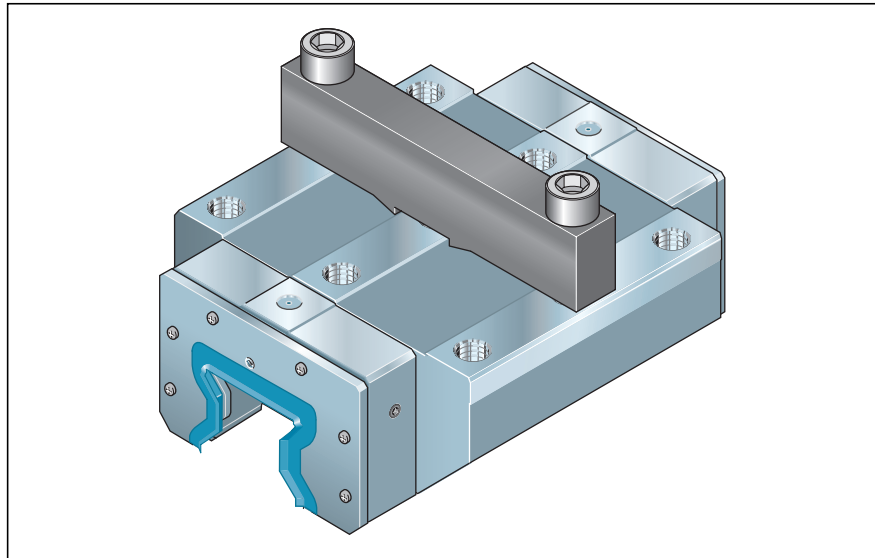

Size	Part numbers	Weight kg
100	R1869 240 09	on request
125	R1869 340 09	7

Accessories and Spare Parts

General Accessories – Guide Rails

General accessories

Adjusting shafts

Mounting aid
for composite guide rails

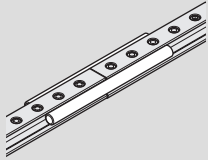

Wedge profile

Mounting aid
for lateral retention of guide rails

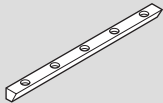

Mounting runner block

Mounting aid
for parallel alignment
of standard guide rails

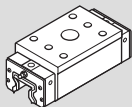

...in the appropriate dimensions,
suitable for...

Standard guide rails

For mounting from above,
with cover strip and
screw-down protective caps

R1805 .6. ..
Steel
R1845 .6. ..
Resist CR¹⁾

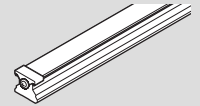

For mounting from above,
with cover strip and strip clamps

R1805 .3. ..
Steel
R1845 .3. ..
Resist CR¹⁾

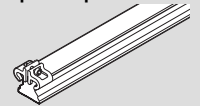

For mounting from above,
for cover strip

R1805 .2. ..
Steel
R1845 .7. ..
Resist CR¹⁾

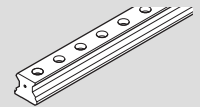

For mounting from above,
with plastic mounting hole plugs

R1805 .5. ..
Steel
R1845 .0. ..
Resist CR¹⁾

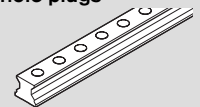

For mounting from above,
for steel mounting hole plugs

R1806 .5. ..
Steel
R1846 .0. ..
Resist CR¹⁾

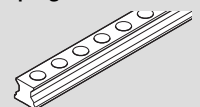

For mounting from below

R1807 .0. ..
Steel
R1847 .0. ..
Resist CR¹⁾

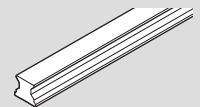

Wide guide rails

With cover strip, screws and washers

R1875 .6. ..
Steel
R1873 .6. ..
Resist CR¹⁾

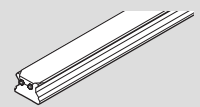

Heavy duty guide rails

With cover strip, screws and washers

R1835 .6. ..
Steel
R1865 .6. ..
Resist CR¹⁾

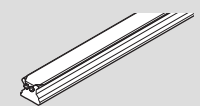

1) Corrosion-resistant guide rails, Resist CR, matte silver hard chrome plated, replace the guide rails with zinc-iron coating.

Accessories and Spare Parts

General Accessories – Guide Rails

Adjusting shafts

Mounting aid for composite guide rails

Notes

Adjusting shafts are especially helpful when there is no reference edge.

Observe the “Mounting Instructions for Roller Rail Systems.”

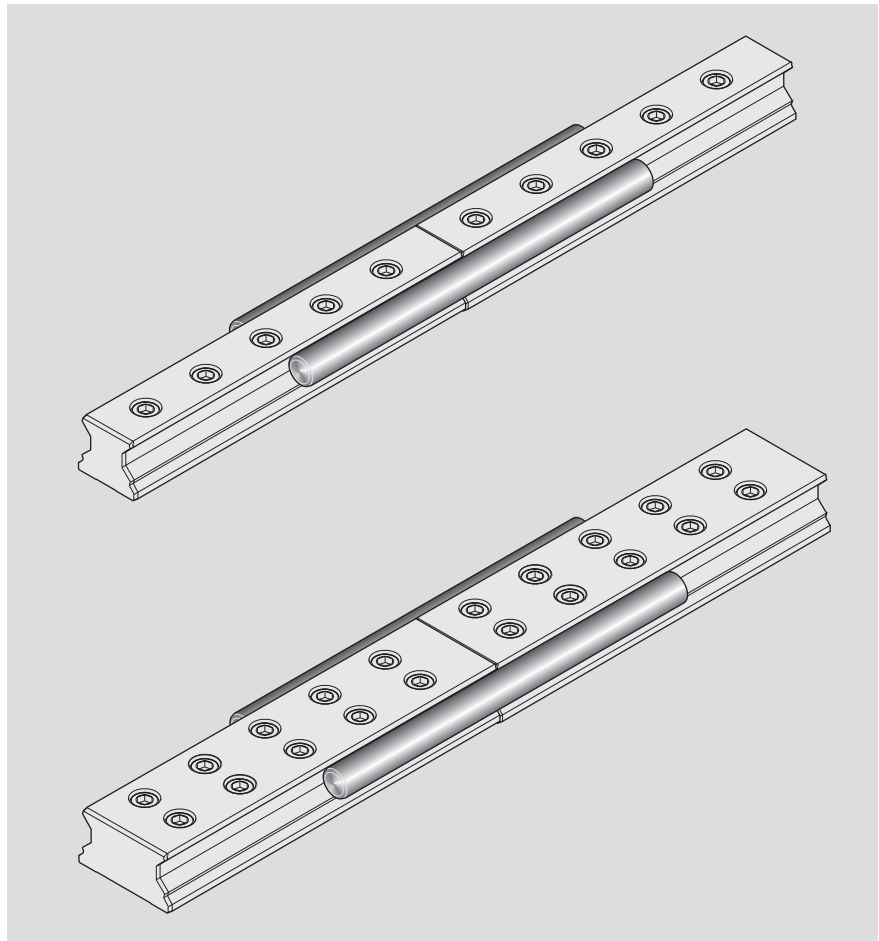

Note for ordering

Always order **two** adjusting shafts for mounting.

Size	Part numbers Adjusting shaft (single)	Dimensions (mm)		Weight kg
		Shaft dia.	Length	
25	–	–	–	–
35	R1810 390 01	20	160	0.4
45	R1810 490 01	25	200	0.8
55	R1810 590 01	30	250	1.4
65	R1810 690 01	35	300	2.3
55/85	R1810 590 01	30	250	1.4
65/100	R1810 690 01	35	300	2.3
100	R1810 291 01	75	400	13.9
125	R1810 391 01	80	600	23.7

Accessories and Spare Parts

General Accessories – Guide Rails

Wedge profile

Mounting aid for lateral retention of guide rails

Material: steel
Version: black finished

Observe the "Mounting Instructions for Roller Rail Systems."

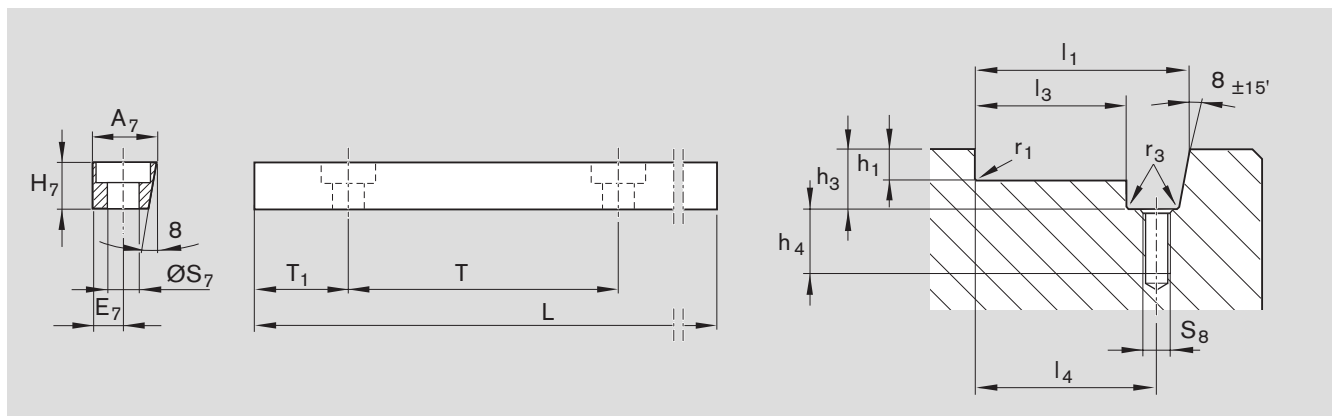
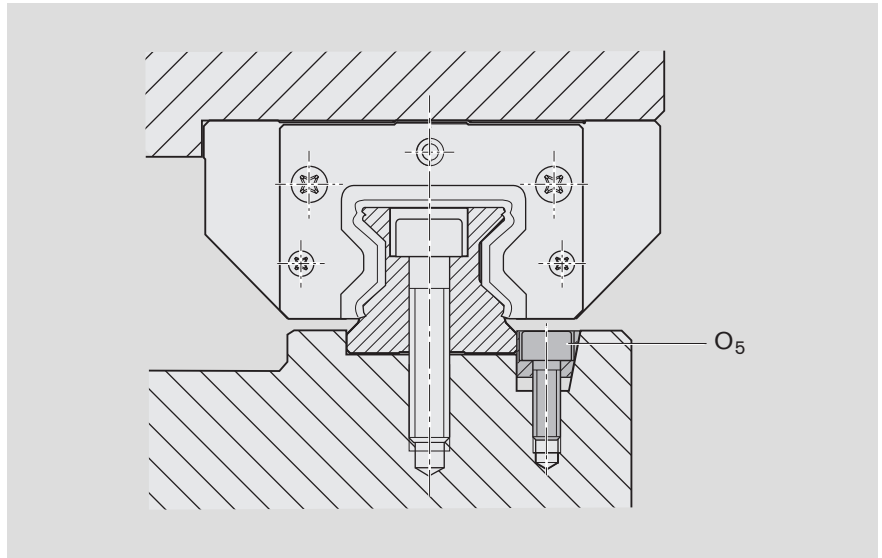

Wedge profile

Size	Part numbers	Dimensions (mm)								Weight kg
		A ₇	E ₇	H ₇	L	O ₅ ¹⁾	S ₇	T	T ₁	
25	R1619 200 01	12.0	6	10	957	M5x20	6.0	60	28.5	0.8
35										
45	R1619 400 01	19.0	9	16	942	M8x25	9.0	105	51.0	2.0
55										
65										
100 ²⁾	R1810 291 02	34.0	16	23	938	M12x35	13.5	105	49	5.3
125	R1810 391 02	47.5	23	30	954	M16x45	17.5	120	57.0	9.5

1) Screw O₅ to DIN 6912

2) Size 100 on request

Wedge profile groove

Size	Dimensions (mm)									
	h _{1-0.2}	h ₃₊₁	h ₄₊₂	l _{1±0.05}	l _{3-0.1}	l _{4±0.1}	r _{1 max}	r _{3 max}	S ₈	
25	4.5	12.5	15	35.1	22.9	29	0.8	0.5	M5	
35	5.0	12.5	15	46.1	33.9	40	0.8	0.5	M5	
45	7.0	19.0	16	64.1	44.9	54	0.8	0.5	M8	
55	9.0	19.0	16	72.1	52.9	62	1.2	0.5	M8	
65	9.0	19.0	16	82.1	62.9	72	1.2	0.5	M8	
100	12.0	26.0	20	134.0	99.9	116	1.8	1.0	M12	
125	20.0	34.0	29	172.6	124.9	148	1.8	1.0	M16	

Accessories and Spare Parts

General Accessories – Guide Rails

Mounting runner block

SLH R1829
Slimline, long, high

Mounting aid for parallel alignment of
standard guide rails

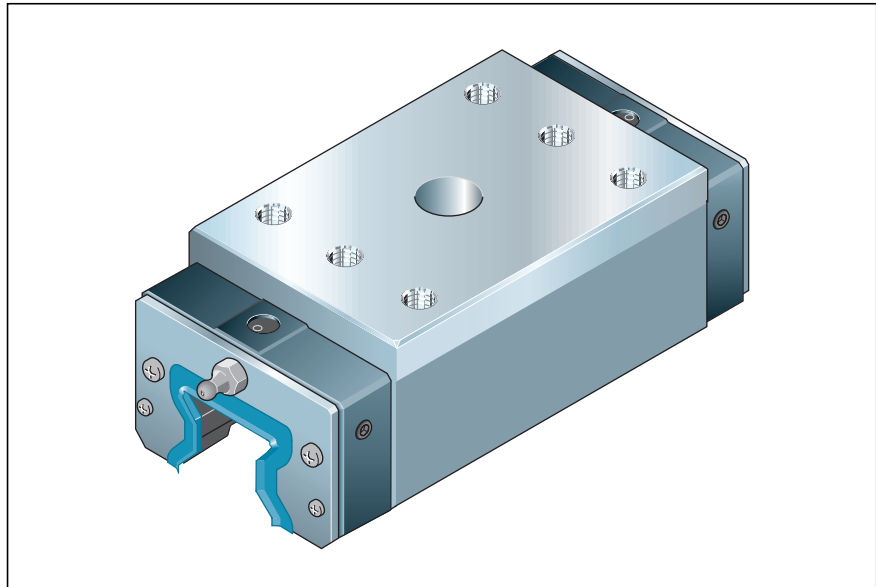

Size	Part numbers for preload class
	C3
25	R1829 220 27
35	R1829 320 39
45	R1829 420 53
55	R1829 520 14
65	R1829 620 04

Preload class

C3 = preload 13% C

Note

Hole D serves both as key hole and screw hole.

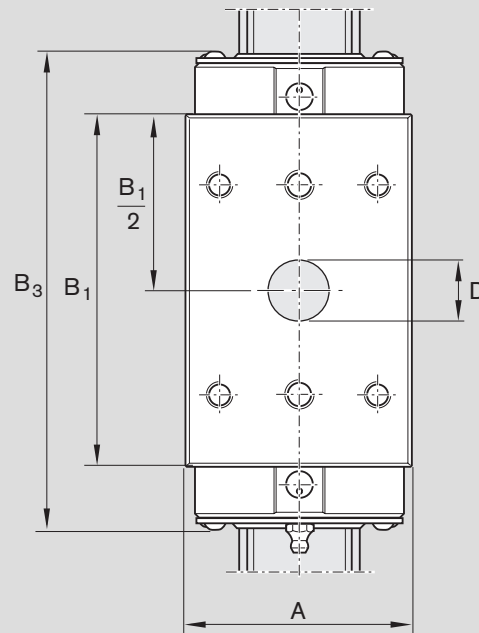
Mounting runner block SLH R1829

Size	Dimensions ¹⁾ (mm)				Weight kg
	A	B ₁	B ₃	D	
25	48	81.5	115	19	0.8
35	70	103.6	145	25	1.9
45	86	134.0	183	27	4.0
55	100	162.1	216	27	6.0
65	126	194.0	264	30	11.8

1) For all other dimensions, see runner blocks SLH R1824 ... 10

Mounting with mounting runner block

The central hole D in the mounting runner block allows precise measurement of the relative rail position. The rail mounting screws can also be driven down through this hole.

Aligning the rails

- Align and mount the first rail using a graduated straightedge.
- Set up a mounting bridge with dial gauge between the runner blocks.
- Move both runner blocks in parallel until hole D in the mounting runner block is positioned precisely above a mounting hole in the rail.
- Align the guide rail manually until the dial gauge shows the correct dimension.
- Then screw down the rail through hole D in the mounting runner block.

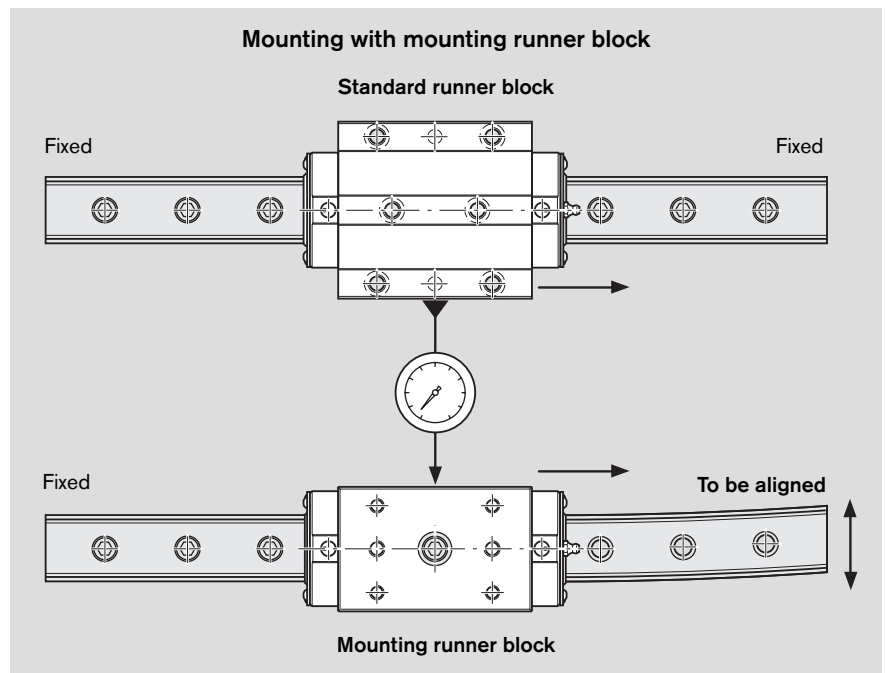
Mounting with mounting runner block

Accessories and Spare Parts

Spare Parts

Spare parts for runner blocks

End seal

Only for replacement on **new** runner block

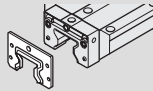

Set of end caps with end seals

For replacement as part of system servicing

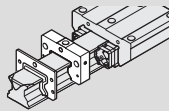

Transport and mounting arbor

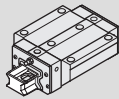

Set of end caps with end seals

For replacement as part of system servicing

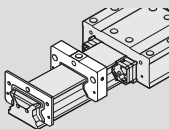

Transport and mounting arbor

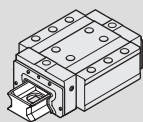

...in the appropriate dimensions, suitable for...

...in the appropriate dimensions, suitable for...

Standard runner blocks

Flanged, normal, standard height FNS

Steel:

R1851 ... 10

R1851 ... 13 with Al end caps

R1851 ... 16 for oil/grease lubrication from above

R1851 ... 17 for central oil lubrication systems

R1851 ... 18 for wall mounting

Resist CR¹⁾:

R1851 ... 6. (last digit same as in corresponding steel runner block)

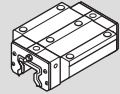

Flanged, long, standard height FLS

Steel:

R1853 ... 10

R1853 ... 13 with Al end caps

R1853 ... 16 for oil/grease lubrication from above

R1853 ... 17 for central oil lubrication systems

R1853 ... 18 for wall mounting

Resist CR¹⁾:

R1853 ... 6. (last digit same as in corresponding steel runner block)

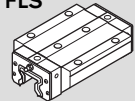

Slimline, normal, high SNH

Steel:

R1821 ... 10

R1821 ... 13 with Al end caps

R1821 ... 16 for oil/grease lubrication from above

R1821 ... 17 for central oil lubrication systems

R1821 ... 18 for wall mounting

Resist CR¹⁾:

R1821 ... 6. (last digit same as in corresponding steel runner block)

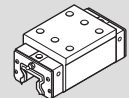

Slimline, long, high SLH

Steel:

R1824 ... 10

R1824 ... 13 with Al end caps

R1824 ... 16 for oil/grease lubrication from above

R1824 ... 17 for central oil lubrication systems

R1824 ... 18 for wall mounting

Resist CR¹⁾:

R1824 ... 6. (last digit same as in corresponding steel runner block)

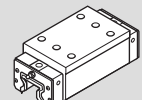

Wide runner blocks

Wide, long, standard height BLS

R1872 ... 10 Steel

R1872 ... 60 Resist CR¹⁾

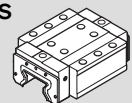

Heavy duty runner blocks

Flanged, normal, stand. height FNS

R1861 ... 10 Steel

R1861 ... 60 Resist CR¹⁾

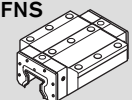

Flanged, long, standard height FLS

R1863 ... 10 Steel

R1863 ... 60 Resist CR¹⁾

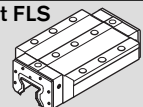

1) Corrosion-resistant runner blocks, Resist CR, matte silver hard chrome plated, replace the runner blocks with zinc-iron coating.

Accessories and Spare Parts

Spare Parts

End seal

Only for replacement on new runner block

- Material: corrosion-resistant spring steel to EN 10088 with polymer seal
- Version: bright

Mounting instructions

Comes complete with mounting screws.

- Dispose of the old screws.

For detailed information on mounting, see "Mounting Instructions for Roller Rail Systems."

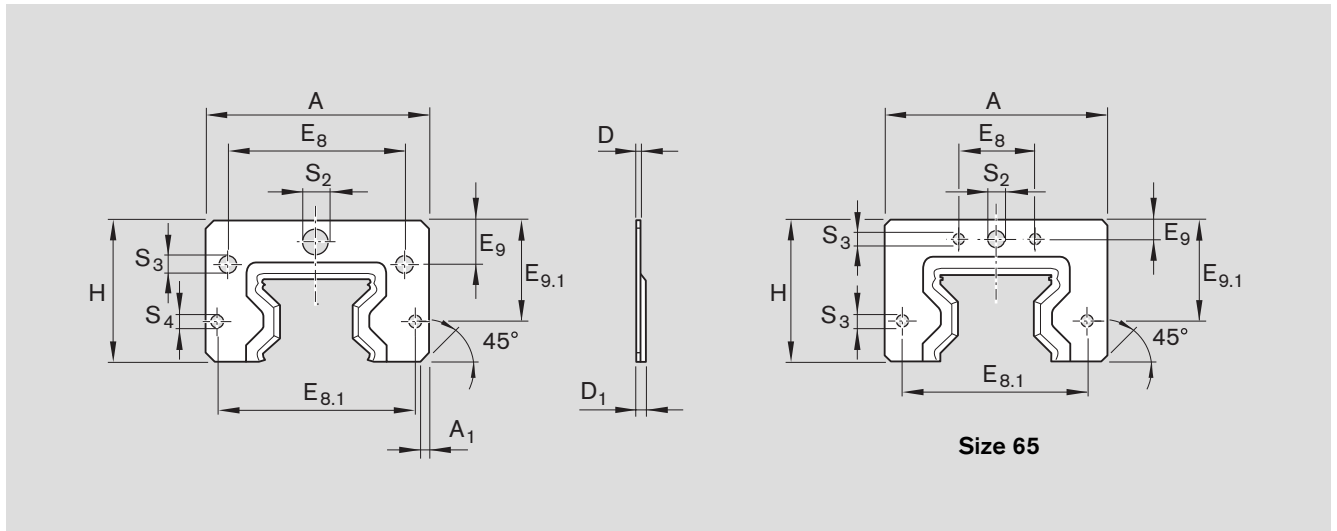
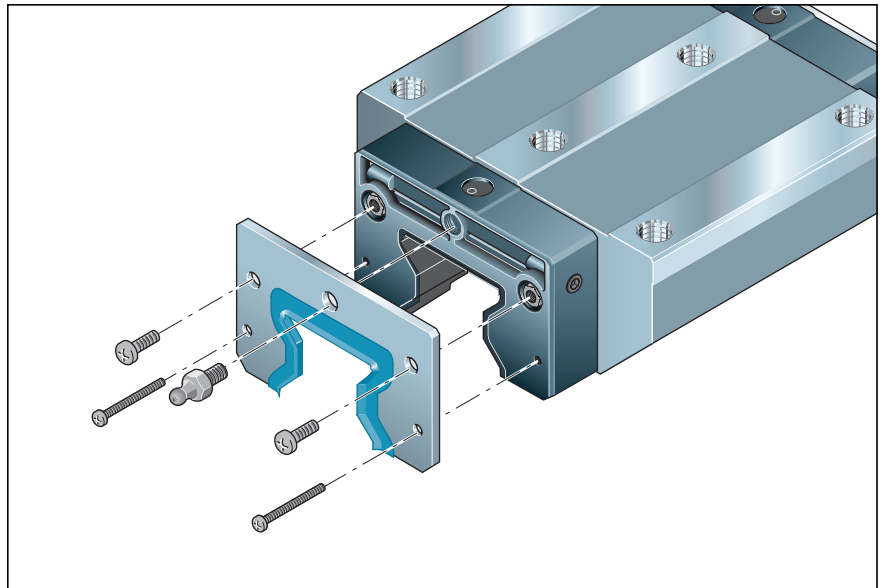

Size	Part numbers Kit ¹⁾	Dimensions (mm)												Weight g
		A	A ₁	D	D ₁	E ₈	E _{8.1}	E ₉	E _{9.1}	H	S ₂	S ₃	S ₄	
25	R1810 210 00	44.0	1.2	1.0	2.6	33.4	40.2	7.9	20.7	28.5	7	4.0	3.0	13
35 ²⁾	R1810 310 00	63.0	2.0	1.0	2.6	50.3	56.6	12.4	28.4	39.8	7	4.0	3.0	20
45 ²⁾	R1810 410 00	77.0	2.0	2.0	4.0	62.9	69.6	16.0	35.8	49.8	7	5.0	4.0	46
55 ²⁾	R1810 510 00	90.5	2.0	2.0	4.8	74.2	81.6	18.2	40.0	56.2	7	6.0	4.0	58
65	R1810 610 00	119.0	3.0	2.0	5.0	35.0	106.0	8.3	54.0	74.5	7	5.0	5.0	108
100	R1810 211 00	181.0	2.0	2.5	5.5	130.0	162.6	28.4	61.0	104.0	9	6.0	6.0	280
125	R1810 311 00	230.0	5.0	3.0	6.0	205.0	205.0	38.0	90.0	133.0	9	6.5	6.5	530

1) Kit with screws

2) Kit for runner block R18.. ... 18 or ... 68 (wall mounting) on request

Accessories and Spare Parts

Spare Parts

Set of end cap with end seal

For replacement as part of runner block servicing

Mounting instructions

Comes complete with mounting screws.

- Dispose of the old screws.

For detailed information on mounting, see "Mounting Instructions for Roller Rail Systems."

Set for standard runner blocks and wide runner blocks 65/100 (diagrams for illustration only)

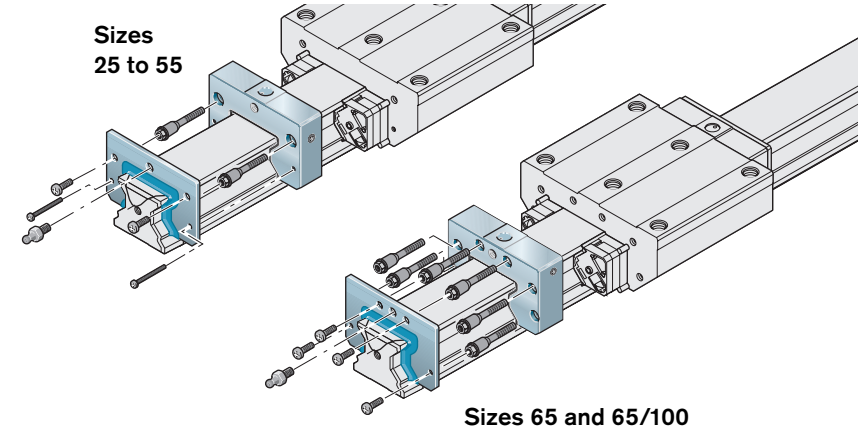

Size	Part numbers for set of end cap with end seal to match standard runner blocks						
	R18... 10	with Al end caps	for oil/grease lubrication from above	for central oil lubrication systems	for wall mounting		
	R18... 60	R18... 13 R18... 63	R185... 16 R185... 66	R182... 16 R182... 66	R185... 17 R185... 67	R182... 17 R182... 67	R18... 18 R18... 68
25	R1810 290 10	–	R1810 290 81	R1810 290 82	–	–	–
35	R1810 390 10	R1810 390 60	R1810 390 81	R1810 390 82	R1810 390 83	R1810 390 84	R1810 390 80
45	R1810 490 10	R1810 490 60	R1810 490 81	R1810 490 82	R1810 490 83	R1810 490 84	R1810 490 80
55	R1810 590 10	R1810 590 60	R1810 590 81	R1810 590 82	R1810 590 83	R1810 590 84	R1810 590 80
65	R1810 690 10	R1810 690 60	R1810 690 81	R1810 690 81	–	–	R18... .. 1)

1) Runner block R1859 620 31 size 65 (only) for wall mounting on request

Size	Weight of set with end caps made from	
	plastic kg	aluminum kg
25	0.03	–
35	0.05	0.07
45	0.09	0.15
55	0.12	0.18
65	0.26	0.42
55/85	–	0.30
65/100	–	0.65
100	0.61	–
125	–	2.30

Set for wide runner blocks and heavy duty runner blocks (diagrams for illustration only)

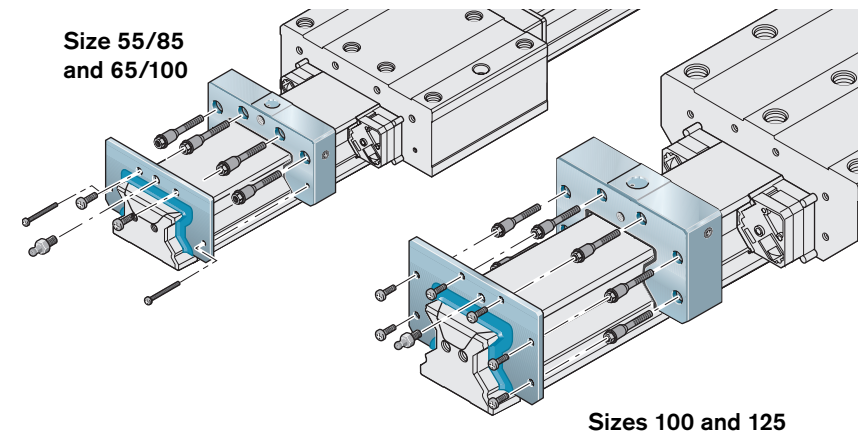

Size	Part numbers for set of end cap with end seal to match	
	Wide runner blocks R1872 ... 10 and R1872 ... 60	Heavy duty runner blocks R186 ... 10 and R186 ... 60
55/85	R1810 592 60 ¹⁾	–
65/100	R1810 692 60 ¹⁾	–
100	–	R1810 291 10
125	–	R1810 391 60 ¹⁾

1) Aluminum end caps

Accessories and Spare Parts

Spare Parts

Transport and mounting arbor for runner blocks

For shipping and as a mounting aid

– Material: plastic

Notes

The runner block simply slides off its arbor and onto the rail.

Please refer to the "Mounting Instructions" section.

⚠ The mounting arbor must remain in the runner block until the block is pushed onto the guide rail. Otherwise, rollers may be lost!

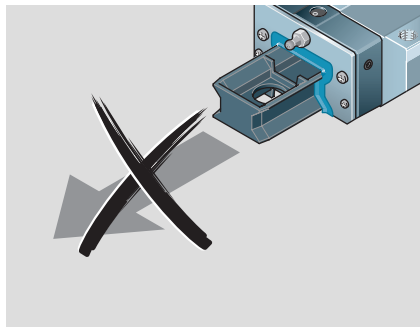
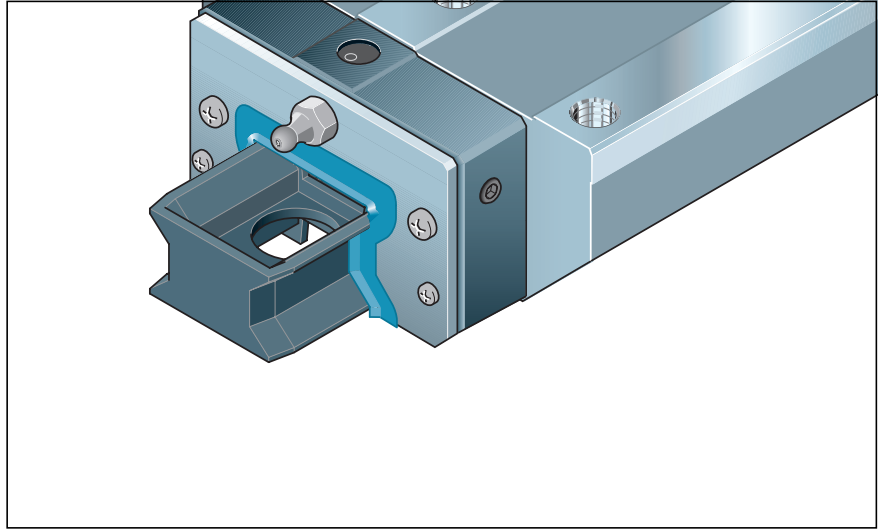

Size	Standard		Long	
	Part numbers	Weight (g)	Part numbers	Weight (g)
25	R1851 200 91	5.6	R1853 200 91	6.3
35	R1851 300 91	13.5	R1853 300 91	16.2
45	R1851 400 91	22.2	R1853 400 91	26.8
55	R1851 500 91	32.5	R1853 500 91	36.7
65	R1853 600 91	40.7	R1853 600 91	40.7
55/85	–	–	R1871 500 81	367.0
65/100	–	–	R1871 600 81	663.0
100	R1861 200 91	154.0	R1863 200 91	197.0
125	R1861 300 81	1888.0	R1863 300 81	2600.0

Mounting Instructions

General Mounting Instructions

General notes

The following installation notes apply to all Roller Rail Systems.

⚠ In overhead mounting orientations (suspended top down) the runner block could possibly come away from the rail due to loss or breakage of rollers. Secure the runner block against falling!

Rexroth roller rail systems are high quality, precision manufactured products and must therefore be handled with the utmost care in transit and during subsequent installation. The same care must be taken with cover strips. All steel parts are treated with anticorrosion oil prior to shipment. It is not necessary to remove this oil provided the recommended lubricants are used.

Parallelism offset of mounted rails

Values measured at the guide rails and at the runner blocks

The parallelism offset P_1 causes a slight increase in preload on one side of the assembly.

As long as the values specified in the table are met, the effect of this on the service life can generally be neglected.

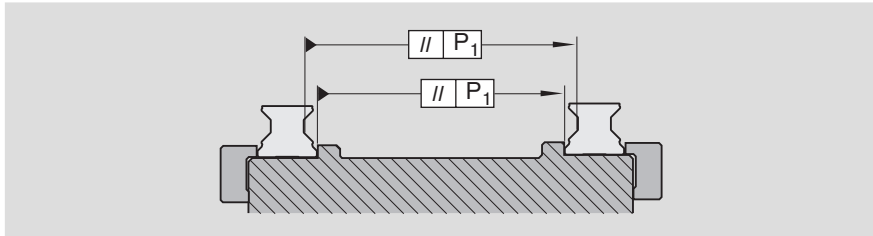

Roller Rail System	Size	Parallelism offset P_1 (mm) for preload class	
		C2	C3
Standard	25	0.007	0.005
	35	0.010	0.007
	45	0.012	0.009
	55	0.016	0.011
	65	0.022	0.016
Wide	55/85	0.016	0.011
	65/100	0.022	0.016
Heavy duty	100	0.029	0.022
	125	0.034	0.026

Preload classes

C2 = preload 8% C

C3 = preload 13% C

Mounting with mounting runner block

The central hole D in the mounting runner block allows precise measurement of the relative rail position. The rail mounting screws can also be driven down through this hole.

Aligning the rails

- Align and mount the first rail using a graduated straightedge.
- Set up a mounting bridge with dial gauge between the runner blocks.
- Move both runner blocks in parallel until hole D in the mounting runner block is positioned precisely above a mounting hole in the rail.
- Align the guide rail manually until the dial gauge shows the correct dimension.
- Then screw down the rail through hole D in the mounting runner block.

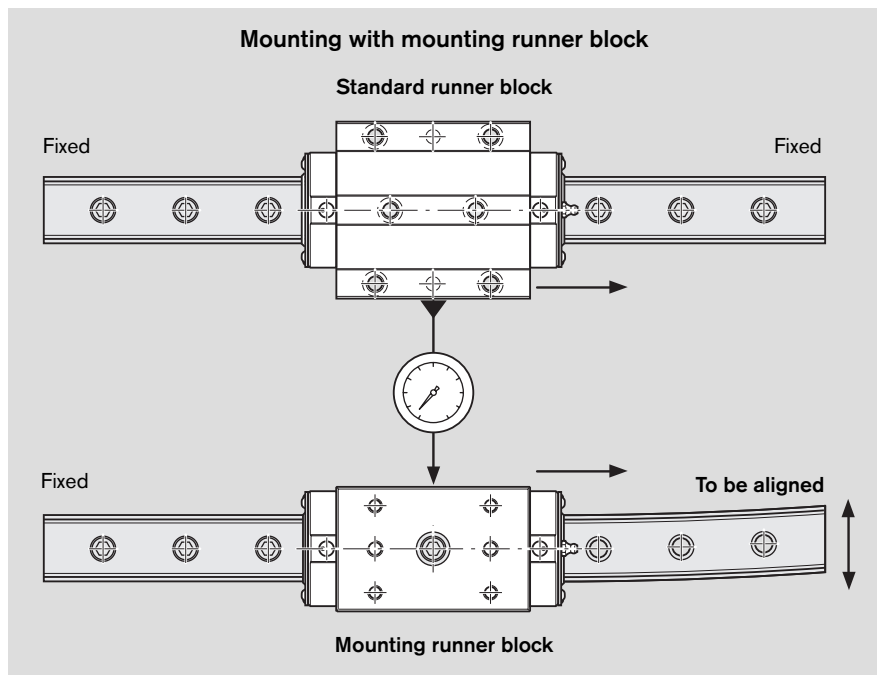

Mounting Instructions

General Mounting Instructions

Vertical offset

Provided the vertical offset is kept within the stated tolerances for S_1 and S_2 , its influence on the service life can generally be neglected.

Permissible vertical offset in the transverse direction S_1

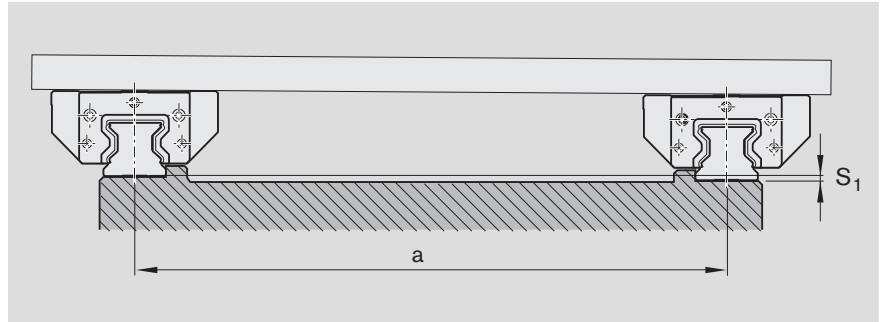

The tolerance for dimension H, as given the table with accuracy classes in the "General Product Description" section, must be deducted from the permissible vertical offset S_1 .

$$S_1 = a \cdot Y$$

S_1 = permissible vertical offset of the guide rails (mm)
 a = distance between guide rails (mm)
 Y = calculation factor

Calculation factor	For preload class	
	C2	C3
Y	$1.7 \cdot 10^{-4}$	$1.2 \cdot 10^{-4}$

Permissible vertical offset in the longitudinal direction S_2

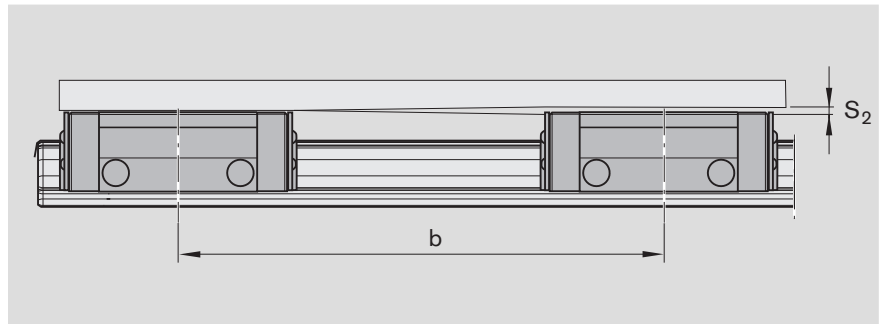

The tolerance "max. difference in dimension H on the same rail", as given the table with accuracy classes in the "General Product Description" section, must be deducted from the permissible vertical offset S_2 .

$$S_2 = b \cdot X$$

S_2 = permissible vertical offset of the runner blocks (mm)
 b = distance between runner blocks (mm)
 X = calculation factor

Calculation factor	For runner block length	
	Standard	Long
X	$4.3 \cdot 10^{-5}$	$3.0 \cdot 10^{-5}$

Runner block with standard length

- Standard roller rail system
FNS R1851, SNH R1821
- Heavy duty roller rail system
FNS R1861

Runner block, long

- Standard roller rail system
FLS R1853, SLH R1824
- Wide roller rail system
BLS R1872
- Heavy duty roller rail system
FLS R1863

Mounting Instructions

General Mounting Instructions

Shipment of guide rails

One-piece guide rails

Standard: One-piece roller guide rails with cover strip are shipped with the cover strip clipped on, both ends angled down and with protective caps screwed on.

If required, guide rails can also be supplied with a separate cover strip.

Composite guide rails

The cover strip and protective caps are supplied complete with screws and washers in a separate packing unit.

The packing unit is marked with the same manufacturing job number as the labels on the guide rails.

The cover strips have one angled down and one straight end (strip tongue).

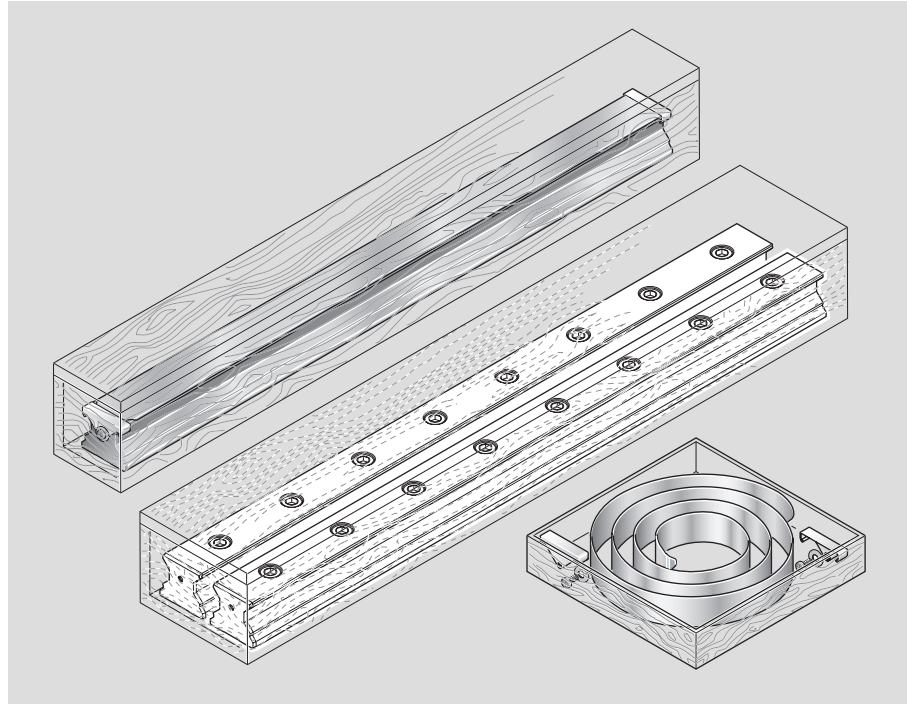

Composite guide rails

Matching sections of a composite guide rail are identified as such by a label on the packaging.

All sections of the same rail have the same number, which is marked on the top of the guide rail.

Standard guide rail made up of two sections

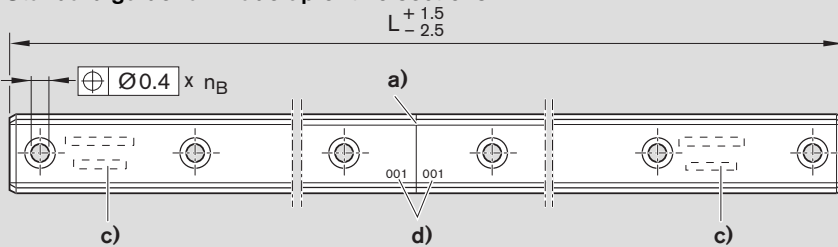

n_B Number of holes

a) Joint (sharp-edged, now also in hard chrome plated guide rails)

b) Rail number

c) Full rail identification on first and last sections

d) Joint number

Standard guide rail made up of three or more sections

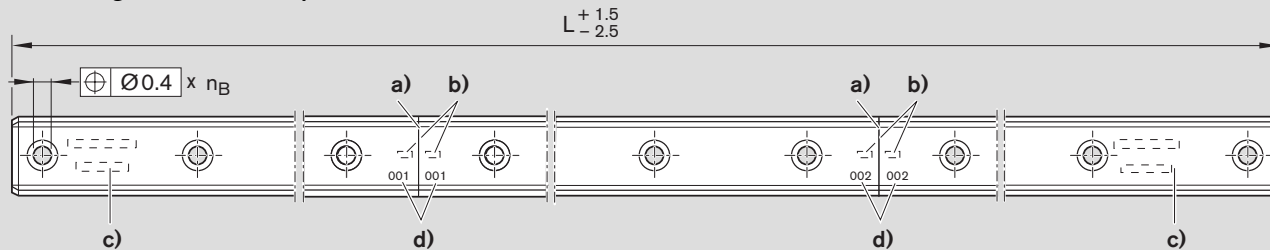

Note on cover strip

For composite rails, a cover strip to cover the total length L is supplied separately along with the rails.

Adjusting shaft

The sections of composite rails can be aligned with the aid of an adjusting shaft. For more detailed information see

“Accessories” and “Mounting Instructions for Roller Rail Systems.”

Mounting Instructions

General Mounting Instructions

Wide guide rail made up of two sections

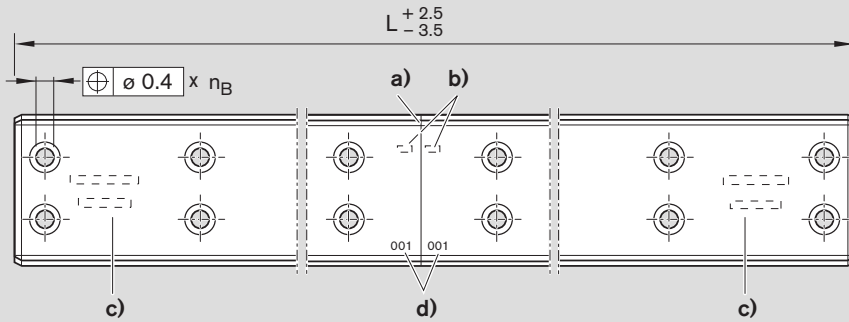

- n_B Number of holes
- a) Joint (sharp-edged, now also in hard chrome plated guide rails)
- b) Rail number
- c) Full rail identification on first and last sections
- d) Joint number

Wide guide rail made up of three or more sections

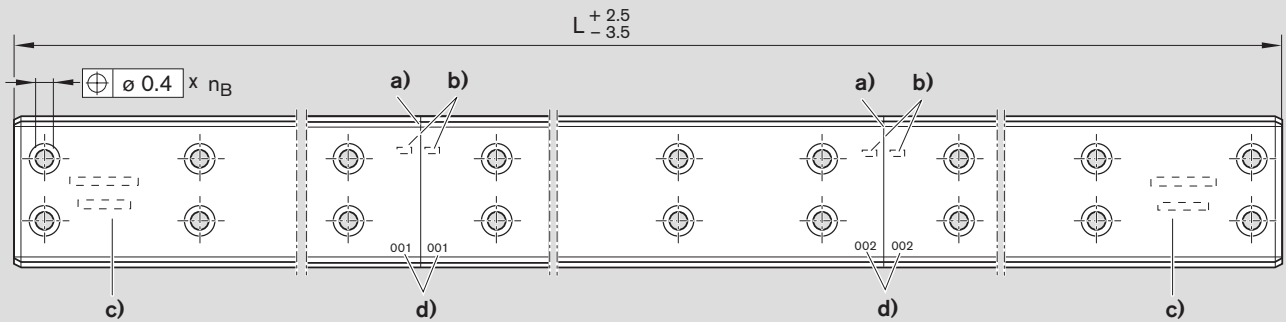

Heavy duty guide rail made up of two sections

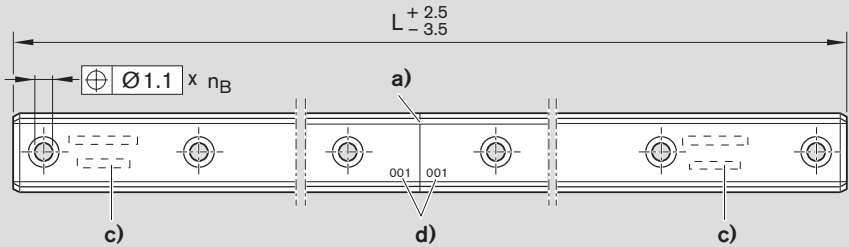

- n_B Number of holes
- a) Joint (sharp-edged, now also in hard chrome plated guide rails)
- b) Rail number
- c) Full rail identification on first and last sections
- d) Joint number

Heavy duty guide rail made up of three or more sections

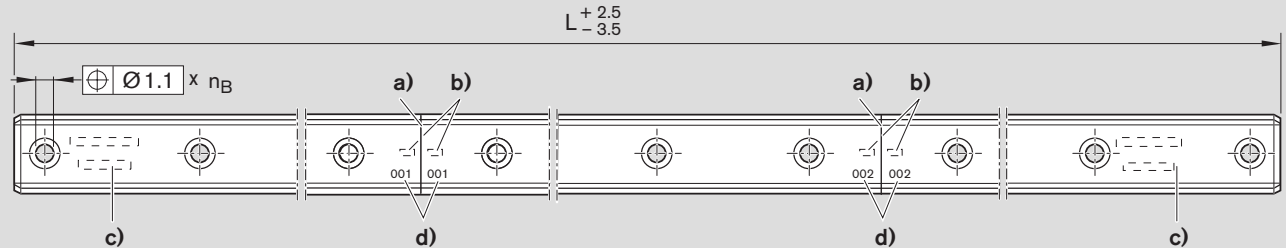

Note on cover strip

For composite rails, a cover strip to cover the total length L is supplied separately along with the rails.

Adjusting shaft

The sections of composite rails can be aligned with the aid of an adjusting shaft. For more detailed information see "Accessories" and "Mounting Instructions for Roller Rail Systems."

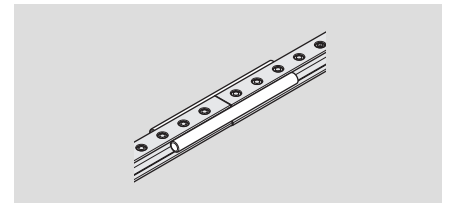

Mounting Instructions

General Mounting Instructions

Mounting examples

Guide rails

Each guide rail has ground reference surfaces on both sides. These are not marked, since each guide rail can be mounted to the left or the right of a reference edge (1) for lateral retention.

Notes

- For guide rails without lateral retention, we recommend using a straight-edge to make sure the rails are properly aligned and parallel during assembly (recommended limits for side load if no additional lateral retention is provided, see "Mounting").
- Use a mounting runner block (see "General Mounting Instructions").
- Install mounting hole plugs or a cover strip (see the relevant Mounting Instructions!):

A After mounting the guide rails, tap the plastic mounting hole plugs into the screw holes with the aid of a plastic pad until flush with the surface of the rail.

B To fit steel mounting hole plugs, always use the special mounting tool (see "Accessories").

The plugs must be flush with the rail surface before mounting the runner block!

C For guide rails with cover strip, see "Notes on cover strip."

Runner blocks

Standard and heavy duty runner blocks have one ground reference edge on each side, while wide runner blocks have two (total of four) (dimension V_1 in the dimension drawings).

⚠ Always fit steel mounting hole plugs before pushing on the runner blocks! Before mounting the runner block, oil or grease the sealing lips of the runner block and the bevel on the end face of the guide rail!

- After sliding the runner block onto the rail, check that it moves easily.

⚠ Then apply initial lubrication (see "Lubrication" section)!

- Detailed information on the mounting procedure can be found in "Mounting Instructions for Roller Rail Systems."

Lateral retention of the guide rails and/or runner blocks (examples)

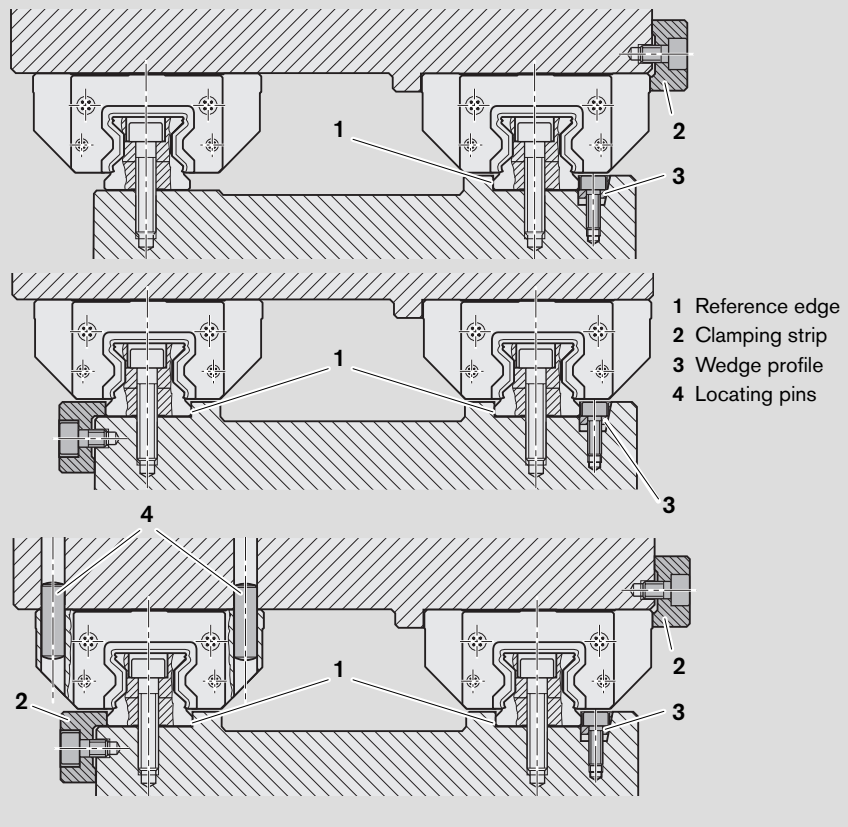

Installing mounting hole plugs or a cover strip to the guide rail

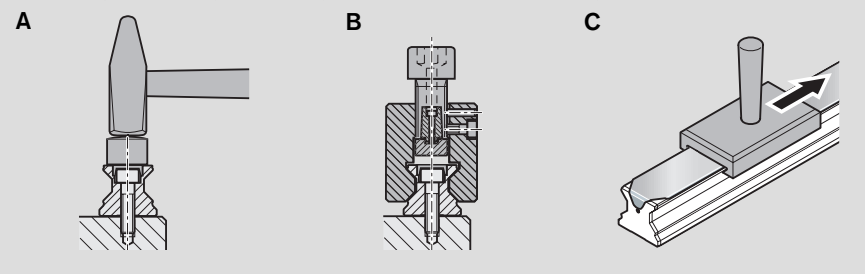

Mounting the runner block

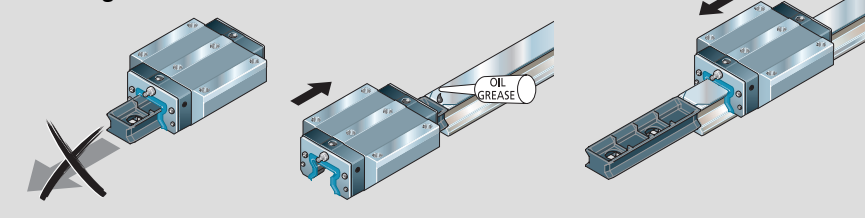

⚠ The transport and mounting arbor must remain in the runner block until the block is pushed onto the guide rail. Otherwise, rollers may be lost!

⚠ Use the mounting arbor again to remove runner blocks from the rail! When not installed on the guide rails, the runner blocks should always be kept on the arbor!

Mounting Instructions

Mounting

Load on the screw connections between the guide rail and the mounting base

The high-performance capability of Roller Rail Systems permits the load limits for screw connections as specified in DIN 645-1 to be exceeded. The most critical point is the screw connection between the guide rail and the mounting base. Screw connections for which the loads F or moment loads M_t exceed the relevant load limits in the table must be separately recalculated (see VDI Guideline 2230).

The values shown in the table apply under the following conditions:

- Mounting screws quality 12.9
- Screws tightened with a torque wrench
- Screws lightly oiled
(for screws in quality 8.8, an approximation factor of 0.6 can be applied).
- Parts screwed down to steel or cast iron bases
- Screw-in depth at least 2x thread diameter

Standard roller rail systems

Guide rail	Size	Static lift-off loads F and moment loads M_t			
		Runner block, standard length SNH R1821, FNS R1851		Runner block, long SLH (SLS) R1824, FLS R1853	
		F_{max} N	$M_{t max}$ Nm	F_{max} N	$M_{t max}$ Nm
R1805	25	34 300	360	39 200	410
R1806	35	64 500	1 030	73 800	1 180
R1845	45	157 800	3 390	180 400	3 870
	55	216 800	5 400	247 800	6 100
	65	296 000	8 900	339 400	10 100
R1807	25	34 300	360	39 200	410
R1847	35	64 500	1 030	73 800	1 180
	45	157 800	3 390	180 400	3 870
	55	216 800	5 400	247 800	6 100
	65	296 000	8 900	339 400	10 100

Wide roller rail systems

Guide rail	Size	Static lift-off loads F and moment loads M_t	
		F_{max} N	$M_{t max}$ Nm
R1875	55/85	360 000	10 100
R1873	65/100	494 000	16 500

Heavy duty roller rail systems

Guide rail	Size	Static lift-off loads F and moment loads M_t			
		Runner block, standard length FNS R1861		Runner block, long FLS R1863	
		F_{max} N	$M_{t max}$ Nm	F_{max} N	$M_{t max}$ Nm
R1835	100	686 000	33 270	784 000	38 000
R1865	125	1 102 500	66 150	1 260 000	75 600

Guide rail for mounting from above

Standard: R1805, R1806, R1845
Wide: R1875, R1873
Heavy duty: R1835, R1865

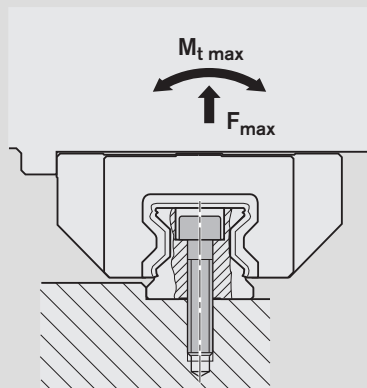

Guide rail for mounting from below

Standard: R1807, R1847

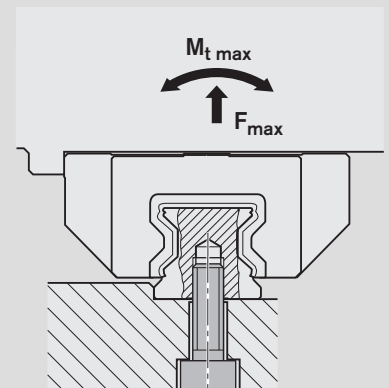

Mounting Instructions

Mounting

Standard Roller Rail Systems

Reference edges and corner radii

Combination examples

The combinations shown here are examples. Basically, any runner block may be combined with any of the rail types offered.

Mounting and lubrication

For details of runner block and guide rail mounting, see "General Mounting Instructions."

For initial and in-service lubrication, see "Lubrication."

Detailed information on the mounting procedure can be found in "Mounting Instructions for Roller Rail Systems."

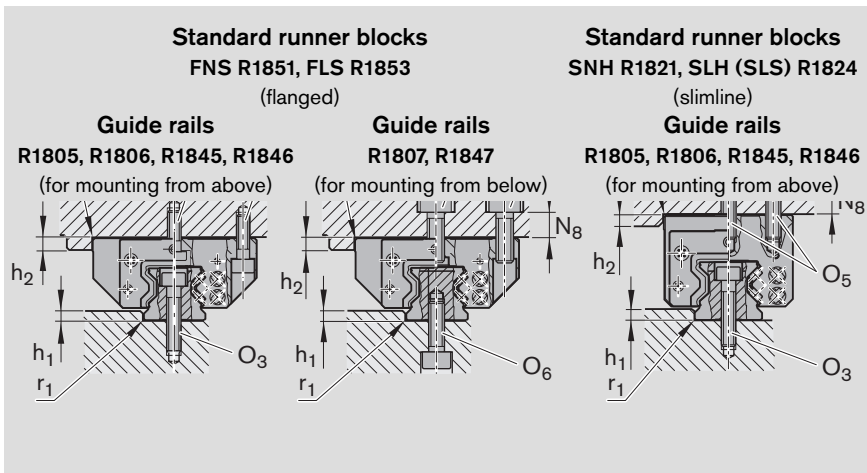

Size	Dimensions (mm)					
	$h_{1\min}$	$h_{1\max}^{1)}$	h_2	N_8	$r_{1\max}$	$r_{2\max}$
25	3.0	4.5	5	10	0.8	0.8
35	3.5	5.0	6	13	0.8	0.8
45	4.5	7.0	8	14	0.8	0.8
55	7.0	9.0	10	20	1.2	1.0
65	7.0	9.0	14	22	1.2	1.0

1) When using braking and clamping units, please take account of the values H_1 from the "Braking and Clamping Units" catalog.

Mounting screws

⚠ Always check the strength factor of the screws in the case of high lift-off loads!

Please refer to the section "Load on the screw connections between the guide rail and the mounting base."

Size	Screw sizes					
	Runner block				Guide rail	
	O_1	$O_2^{1)}$	$O_4^{1) 2)}$	O_5	O_3	O_6
	ISO 4762 4 pieces	DIN 6912 2 pieces	ISO 4762 6 pieces	ISO 4762 6 pieces	ISO 4762	ISO 4762
25	M6x20	M6x16	M8x20	M6x18	M6x30	M6x20
35	M8x25	M8x20	M10x25	M8x25	M8x35	M8x25
45	M10x30	M10x25	M12x30	M10x30	M12x45	M12x30
55	M12x40	M12x30	M14x40	M12x35	M14x50	M14x40
65	M14x45	M14x35	M16x45	M16x40	M16x60	M16x45

- For runner block mounting using 6 screws:
Tighten the centerline screws O_2 , O_4 or O_5 with the tightening torque for strength class 8.8.
- For runner block mounting from above with only 4 O_4 screws:
Permissible side load 1/3 lower, and lower rigidity

Permissible side load

The recommended limits for permissible side loads without additional lateral retention indicate the approximate upper limits for screws in two strength classes.

In other cases, the permissible side load must be calculated from the screw tension force. This can be up to about 15% less when using screws in strength class 10.9 instead of 12.9.

Screw strength class	Permissible side load without lateral retention ¹⁾					
	Runner block				Guide rail	
	O_1	O_2	O_4	O_5	O_3	O_6
8.8 ²⁾	9% C	13% C ⁴⁾	20% C	13% C	10% C	10% C
8.8 ³⁾	7% C	11% C ⁴⁾	16% C	11% C	7% C	7% C
12.9 ²⁾	15% C	19% C ⁴⁾	30% C	22% C	17% C	17% C
12.9 ³⁾	12% C	16% C ⁴⁾	23% C	18% C	12% C	12% C

- Calculated with friction coefficient $\mu = 0.125$
- Runner blocks FNS, SNH
- Runner blocks FLS, SLH
- For mounting with 2 O_2 screws and 4 O_1 screws

Recommended tightening torques

For $\mu_K = \mu_G = 0.125$

Strength class	Nm max	M6	M8	M10	M12	M14	M16
		8.8	9.5	23	46	80	125
10.9		13.0	32	64	110	180	275
12.9		16.0	39	77	135	215	330

Mounting Instructions

Mounting

Locating pins

⚠ If the recommended limits for permissible side loads are exceeded, the runner block must be additionally fixed!

Possible pin types

- Taper pin (hardened) or
- Straight pin ISO 8734

Notes

Rough-drilled holes made for production reasons may exist at the recommended pin hole positions on the runner block centerline (dia. $< S_{10}$). These may be bored open to accommodate the locating pins.

If the locating pins have to be driven in at another point, dimension E_2 must not be exceeded in the longitudinal direction (for dimension E_2 , see the tables for the individual runner block types).
Observe dimensions E_1 and E_4 !

Standard Roller Rail Systems

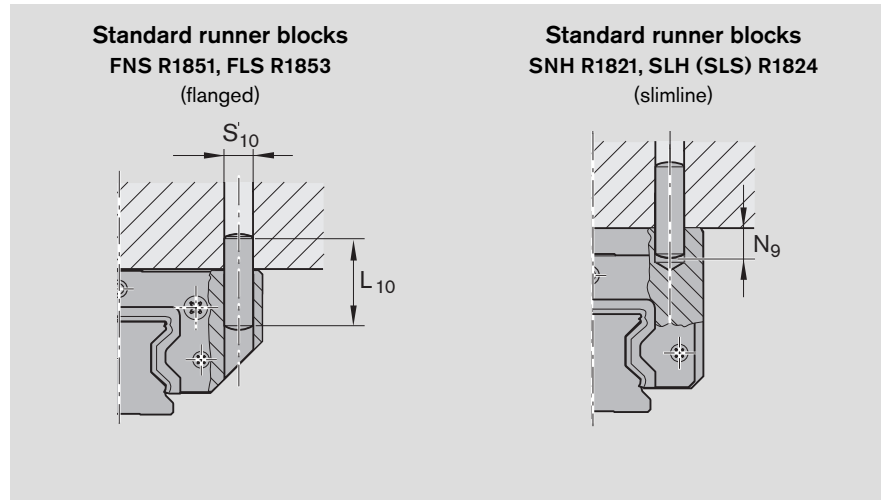

Size	Dimensions (mm)				
	E_1	E_4	$L_{10}^{1)}$	$N_{9 \max}$	$S_{10}^{1)}$
25	35	55	32	9	6
35	50	80	40	13	8
45	60	98	50	18	10
55	75	114	60	19	12
65	76	140	60	22	14

1) Taper pin (hardened) or straight pin (ISO 8734)

Mounting Instructions

Mounting

Wide Roller Rail Systems

Reference edges and corner radii

Mounting and lubrication

For details of runner block and guide rail mounting, see "General Mounting Instructions."

For initial and in-service lubrication, see "Lubrication."

Detailed information on the mounting procedure can be found in "Mounting Instructions for Roller Rail Systems."

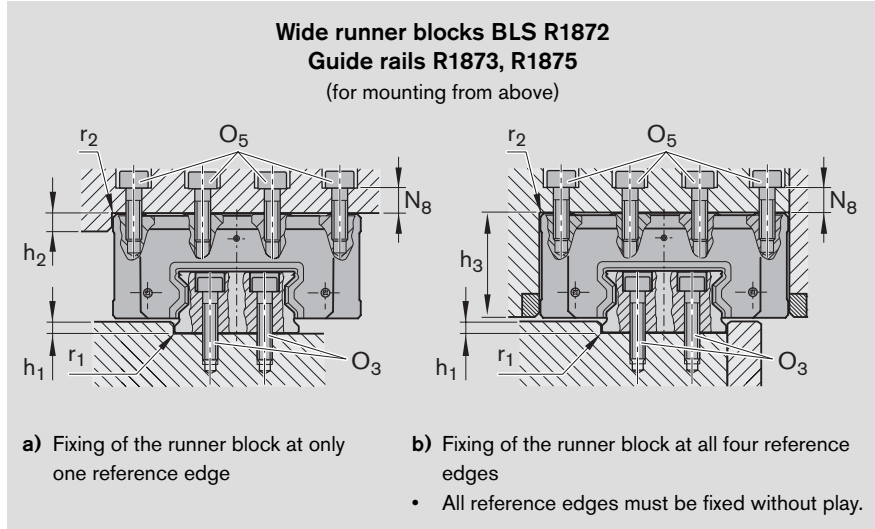

Size	Dimensions (mm)						
	$h_{1 \min}$	$h_{1 \max}$	h_2	h_3	N_8	$r_{1 \max}$	$r_{2 \max}$
55/85	7.0	9.0	10	84	14	1.2	1.0
65/100	7.0	9.0	14	66.5	20	1.2	1.0

Mounting screws

⚠ Always check the strength factor of the screws in the case of high lift-off loads!

Please refer to the section "Load on the screw connections between the guide rail and the mounting base."

Permissible side load

The recommended limits for permissible side loads without additional lateral retention indicate the approximate upper limits for screws in two strength classes. In other cases, the permissible side load must be calculated from the screw tension force. This can be up to about 15% less when using screws in strength class 10.9 instead of 12.9.

Recommended tightening torques

For $\mu_K = \mu_G = 0.125$

Size	Screw sizes	
	Runner block O_5 ISO 4762 6 pieces	Guide rail O_3 ISO 4762
55/85	M12x50	M12x30
65/100	M14x60	M14x35

Screw strength class	Permissible side load without lateral retention ¹⁾	
	Runner block O_5	Guide rail O_3
8.8	16% C ²⁾	16% C
12.9	27% C ²⁾	27% C

1) Calculated with friction coefficient $\mu = 0.125$

2) For runner block mounting using 8 screws

Screw strength class	Nm max	M12	M14
		8.8	80
10.9		110	180
12.9		135	215

Mounting Instructions

Mounting

Reference edges and corner radii

Mounting and lubrication

For details of runner block and guide rail mounting, see "General Mounting Instructions."

To facilitate the mounting of heavy duty runner blocks on the rail, a mounting aid is available on request (see "Accessories").

For initial and in-service lubrication, see "Lubrication."

Detailed information on the mounting procedure can be found in "Mounting Instructions for Roller Rail Systems."

Heavy Duty Roller Rail Systems

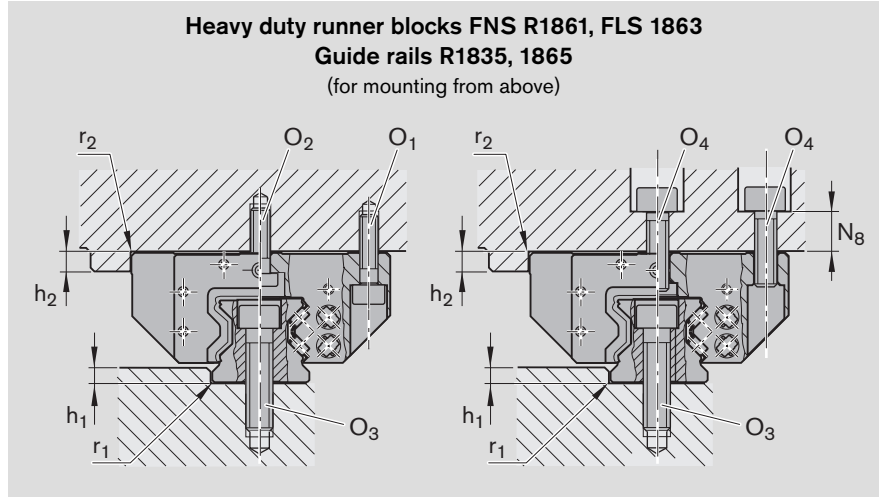

Size	Dimensions (mm)					
	$h_{1 \text{ min}}$	$h_{1 \text{ max}}$	h_2	N_8	$r_{1 \text{ max}}$	$r_{2 \text{ max}}$
100	10	14	18	30	1.8	1.3
125	15	20	23	40	1.8	1.8

Mounting screws

⚠ Always check the strength factor of the screws in the case of high lift-off loads!

Please refer to the section "Load on the screw connections between the guide rail and the mounting base."

Size	Screw sizes			Guide rail O_3 ISO 4762
	Runner block			
	O_1 ISO 4762 6 pieces	$O_2^{1)}$ DIN 6912 3 pieces	$O_4^{1) 2)}$ ISO 4762 9 pieces	
100	M16x60	M16x55	M20x60	M24x100
125	M24x85	M24x70	M27x80	M30x120

- For runner block mounting using 9 screws:
Tighten the centerline screws O_2 , or O_4 along the rail with the tightening torque for strength class 8.8.
- For runner block fixing from above using only 6 O_4 screws:
Permissible side load 1/3 lower, and lower rigidity

Permissible side load

The recommended limits for permissible side loads without additional lateral retention indicate the approximate upper limits for screws in two strength classes. In other cases, the permissible side load must be calculated from the screw tension force. This can be up to about 15% less when using screws in strength class 10.9 instead of 12.9.

Screw strength class	Permissible side load without lateral retention ¹⁾			Guide rail O_3
	Runner block			
	O_1	O_2	O_4	
8.8 ²⁾	9% C	13% C ⁴⁾	20% C	10% C
8.8 ³⁾	7% C	11% C ⁴⁾	16% C	7% C
12.9 ²⁾	15% C	19% C ⁴⁾	30% C	17% C
12.9 ³⁾	12% C	16% C ⁴⁾	23% C	12% C

- Calculated with friction coefficient $\mu = 0.125$
- Runner block FNS R1861
- Runner block FLS R1863
- For mounting with 3 O_2 screws and 6 O_1 screws

Recommended tightening torques

For $\mu_K = \mu_G = 0.125$

Nm max	⌚	M16	M20	M24	M27	M30
		8.8	195	390	660	980
10.9		280	560	930	1 400	1 850
12.9		330	650	1 100	1 650	2 250

Lubrication and Maintenance

Lubrication

Rexroth Roller Rail Systems are delivered filled with an anti-corrosion agent.

Immediately after mounting the runner blocks (before start-up), make sure the system has sufficient initial lubrication (basic lubrication).

Depending on the runner block type, the following lubricant types are possible:

- Both grease and oil
- Oil only

Grease lubrication using grease guns or progressive feeder systems

Recommended grease types

We recommend using **Dynalub 510** with the following properties:

- High performance lithium soap grease, consistency class NLGI 2, to DIN 51818 (KP2K-20 to DIN 51825)
- Good water resistance
- Corrosion protection
- Temperature range: -20 to +80°C

Under conventional environmental conditions this ground-fiber, homogeneous grease is ideally suited for the lubrication of linear elements:

- At loads of up to 50% C
- For short-stroke applications > 1 mm
- For the permissible speed range of Roller Rail Systems

The product and safety data sheets can be found on our website at

www.boschrexroth.de/brl.

Please also read the notes on page 154 of this catalog!

Part numbers for Dynalub 510:

- R3416 037 00 (cartridge 400 g)
- R3416 035 00 (hobcock 25 kg)

Initial lubrication of the runner blocks (basic lubrication)

Stroke ≥ 2 · runner block length B₁ (normal stroke)

- For initial lubrication, mount one lube fitting per runner block, at either of the two end caps!

Initial lubrication is applied in three partial quantities as specified in table 1:

1. Grease the runner block with the first partial quantity as per Table 1, pressing it in slowly with the help of a grease gun.
2. Slide the runner block back and forth over at least three times the block length (size 125: at least 300 mm) for three full cycles.
3. Repeat steps 1. and 2. twice more.
4. Check whether a film of lubricant is visible on the guide rail.

Stroke < 2 · runner block length B₁ (short stroke)

- Install and lubricate two lube fittings per runner block, one on each of the two end caps!

Initial lubrication is applied to each fitting in three partial quantities as specified in table 2:

1. Grease each fitting on the runner block with the first partial quantity as per Table 2, pressing it in slowly with the help of a grease gun.
2. to 4. Repeat the procedure as for initial lubrication (normal stroke).

Size	Initial lubrication (normal stroke) Partial quantity cm ³
25	0.8 (3x)
35	0.9 (3x)
45	1.0 (3x)
55	1.4 (3x)
65	2.7 (3x)
55/85	1.8 (3x)
65/100	3.2 (3x)
100	15.0 (3x)
125	as shown in Fig. 1

Table 1

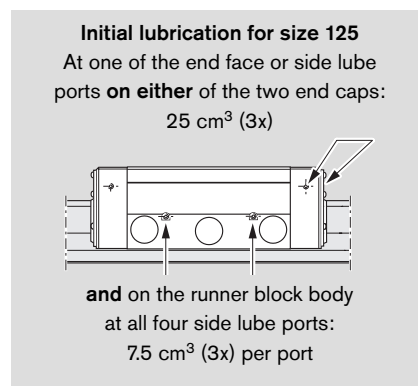

Fig. 1

Size	Initial lubrication (short stroke) Partial quantity per port	
	1st end cm ³	2nd end cm ³
25	0.8 (3x)	0.8 (3x)
35	0.9 (3x)	0.9 (3x)
45	1.0 (3x)	1.0 (3x)
55	1.4 (3x)	1.4 (3x)
65	2.7 (3x)	2.7 (3x)
55/85	1.8 (3x)	1.8 (3x)
65/100	3.2 (3x)	3.2 (3x)
100	15.0 (3x)	15.0 (3x)
125	Lube ports 1st end, 2nd end and sides as shown in Fig. 2	

Table 2

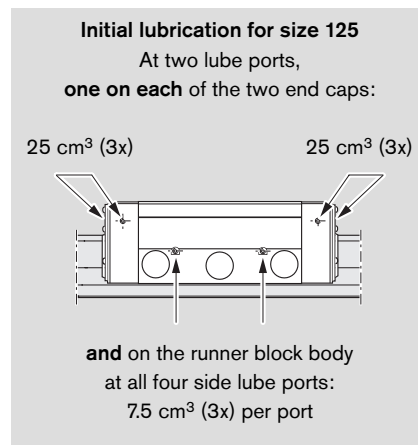

Fig. 2

Lubrication and Maintenance

Lubrication

Grease lubrication using grease guns or progressive feeder systems (continued)

Relubrication of runner blocks

Stroke $\geq 2 \cdot$ runner block length B_1 (normal stroke)

- When the travel distance shown as the relubrication interval in Fig. 5 has been reached, apply the relubrication quantity as specified in Table 3.

Please also read the notes on relubrication on page 154 of this catalog!

Size	Relubrication (normal stroke) cm ³
25	0.8
35	0.9
45	1.0
55	1.4
65	2.7
55/85	1.8
65/100	3.2
100	15.0
125	as shown in Fig. 3

Table 3

Stroke $< 2 \cdot$ runner block length B_1 (short stroke)

- When the travel distance shown as the relubrication interval in Fig. 5 has been reached, apply the relubrication quantity as specified in Table 4.
- At each lubrication cycle the runner block should be traversed through a lubricating stroke of $3 \cdot$ runner block length B_1 . In any case, the lubricating stroke must be at least the length of the runner block. If the largest possible lubricating stroke is smaller than the runner block length B_1 , lubricant must be applied to the guide rail. Please consult us for details.

Please also read the notes on relubrication on page 154 of this catalog!

Size	Relubrication (short stroke) per port	
	1st end cm ³	2nd end cm ³
25	0.8	0.8
35	0.9	0.9
45	1.0	1.0
55	1.4	1.4
65	2.7	2.7
55/85	1.8	1.8
65/100	3.2	3.2
100	15.0	15.0
125	Side ports as shown in Fig. 4	

Table 4

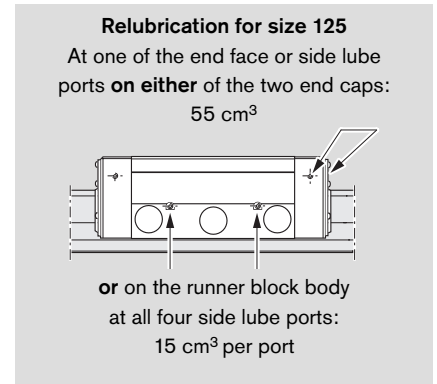

Fig. 3

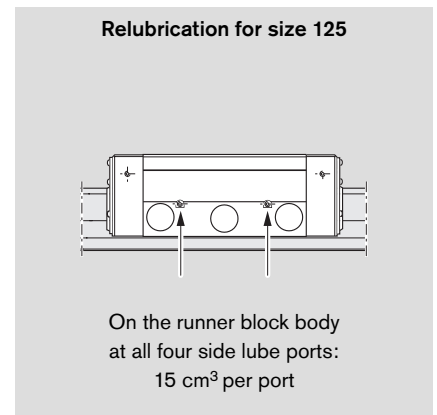

Fig. 4

Lubrication and Maintenance

Lubrication

Grease lubrication using grease guns or progressive feeder systems (continued)

Load-dependent relubrication intervals for grease lubrication using grease guns or progressive feeder systems ("dry axes")

Sizes 25 to 125

The following conditions apply:

- Grease lubricant Dynalub 510
- or alternatively
Castrol Longtime PD 2
- Maximum speed:
 $v_{\max} = 2 \text{ m/s}$
- No exposure to metalworking fluids
- Standard seals
- Ambient temperature:
 $T = 20 - 30^\circ\text{C}$

Key to graph

- s = relubrication interval
expressed as travel (km)
- C = dynamic load capacity (N)
- F = equivalent dynamic load (N)

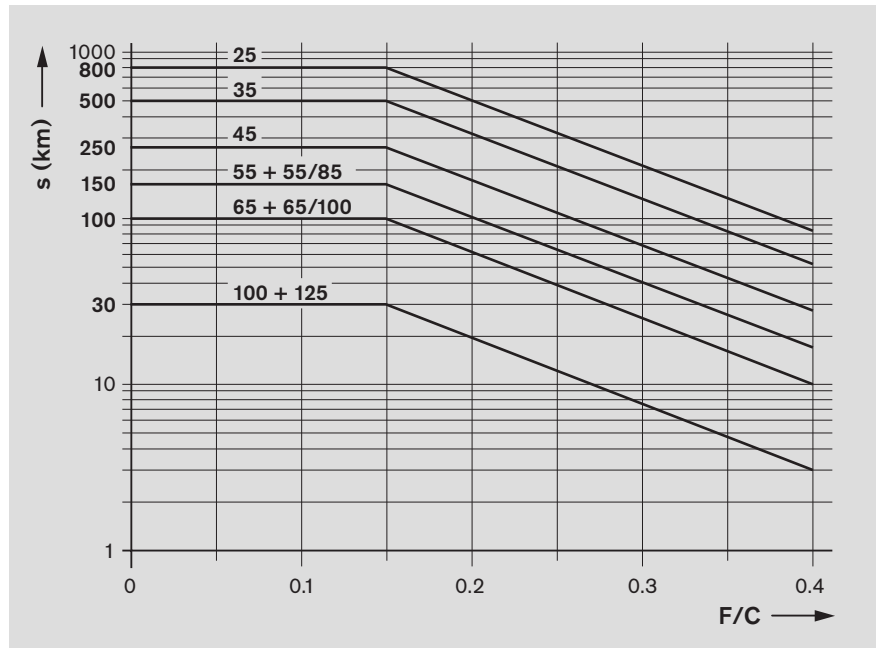

Fig. 5

Notes

The load ratio F/C is the quotient of the equivalent dynamic load on the bearing F (making allowance for a preload of 8% C or 13% C) divided by the dynamic load capacity C (see "General Technical Data and Calculations").

⚠ If other lubricants are used, this may lead to a reduction in the relubrication intervals, the achievable travel in short-stroke applications, and the load capacities. Possible chemical interactions between the plastic materials, lubricants and preservative oils must also be taken into account.

⚠ Do not use greases containing solid particles (e.g., graphite or MoS_2)!

⚠ When using progressive feeder systems, do not go below the minimum dosing quantity for relubrication as given in Table 9.

For relubrication intervals in applications involving exposure to metalworking fluids, please consult us.

⚠ If the system is to be exposed to metalworking fluids, always apply 2 to 5 lubricant pulses at the beginning or when the system has been at a standstill for a longer period. If possible, apply lubricant while the system is in motion. Carry out cleaning and lubricating strokes (see "Maintenance").

⚠ If the application conditions involve dirt, vibrations, impacts, etc. we recommend shortening the relubrication intervals accordingly. Even under normal operating conditions, the system must be relubricated at the latest after 2 years due to aging of the grease.

If your application involves more demanding environmental requirements (such as clean room, vacuum, food industry environment, increased exposure to fluids or aggressive media, extreme temperatures), please consult us. These situations must be investigated on a case by case basis and may require the use of a special lubricant. Be sure to have all the information concerning your application at hand when contacting us.

⚠ Switching from grease to oil lubrication while the system is in service is not possible as the lubrication ducts are already filled with grease, and oil will not be able to pass through them.

Lubrication and Maintenance

Lubrication

Liquid grease lubrication via single-line piston distributor systems

Liquid grease lubrication

We recommend using **Dynalub 520** with the following properties:

- High performance lithium soap grease, consistency class NLGI 00, to DIN 51818 (GP00K-20 to DIN 51826)
- Good water resistance
- Corrosion protection
- Temperature range: –20 to +80°C

Initial lubrication of the runner blocks (basic lubrication)

Stroke $\geq 2 \cdot$ runner block length B_1 (normal stroke)

- For initial lubrication, mount one lube fitting per runner block, at either of the two end caps!

Initial lubrication is applied in three partial quantities as specified in table 5:

1. Grease the runner block with the first partial quantity as per Table 5, pressing it in slowly with the help of a grease gun.
2. Slide the runner block back and forth over at least three times the block length (size 125: at least 300 mm) for three full cycles.
3. Repeat steps 1. and 2. twice more.
4. Check whether a film of lubricant is visible on the guide rail.

Stroke $< 2 \cdot$ runner block length B_1 (short stroke)

- Install and lubricate two lube fittings per runner block, one on each of the two end caps!

Initial lubrication is applied to each fitting in three partial quantities as specified in table 6:

1. Grease each fitting on the runner block with the first partial quantity as per Table 6, pressing it in slowly with the help of a grease gun.
2. to 4. Repeat the procedure as for initial lubrication (normal stroke).

Under conventional environmental conditions this ground-fiber, homogeneous grease is ideally suited for the lubrication of linear elements:

- In single-line centralized lubrication systems
- At loads of up to 50% C
- For short-stroke applications > 1 mm
- For the permissible speed range of Roller Rail Systems
- For miniature versions

We recommend applying initial lubrication with a manual grease gun before connecting the equipment to the centralized lubrication system.

Size	Initial lubrication (normal stroke) Partial quantity cm ³
25	0.8 (3x)
35	0.9 (3x)
45	1.0 (3x)
55	1.4 (3x)
65	2.7 (3x)
55/85	1.8 (3x)
65/100	3.2 (3x)
100	15.0 (3x)
125	as shown in Fig. 6

Table 5

Size	Initial lubrication (short stroke) Partial quantity per port	
	1st end cm ³	2nd end cm ³
25	0.8 (3x)	0.8 (3x)
35	0.9 (3x)	0.9 (3x)
45	1.0 (3x)	1.0 (3x)
55	1.4 (3x)	1.4 (3x)
65	2.7 (3x)	2.7 (3x)
55/85	1.8 (3x)	1.8 (3x)
65/100	3.2 (3x)	3.2 (3x)
100	15.0 (3x)	15.0 (3x)
125	Lube ports 1st end, 2nd end and sides as shown in Fig. 7	

Table 6

The product and safety data sheets can be found on our website at www.boschrexroth.de/brl. Please also read the notes on page 158 of this catalog!

Part numbers for Dynalub 520:

- R3416 043 00 (cartridge 400 g)
- R3416 042 00 (bucket 5 kg)

If initial lubrication is nevertheless carried out via the centralized lubrication system, it is essential that all lines and piston distributors should be filled. The pulse count can then be calculated from the partial quantities and the piston distributor size according to Table 9.

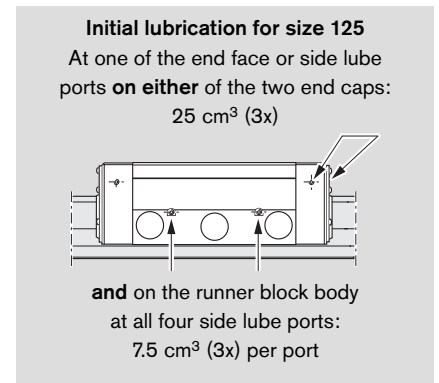

Fig. 6

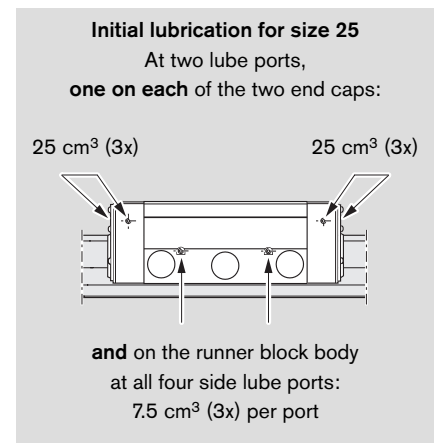

Fig. 7

Lubrication and Maintenance

Lubrication

Liquid grease lubrication via single-line piston distributor systems (continued)

Relubrication of runner blocks

Stroke $\geq 2 \cdot$ runner block length B_1 (normal stroke)

- Apply the minimum quantity according to Table 7 to the lube port until the relubrication interval as specified (in Fig. 10) has been reached.

Notes

The required pulse count is the quotient (as a whole number) of the minimum relubrication quantity according to Table 7 and the smallest permissible piston distributor size (i.e. the minimum pulse quantity) according to Table 9. The smallest permissible piston distributor size also depends on the mounting orientation.

The lubricant cycle time can then be obtained by dividing the relubrication interval (according to Fig. 10) by the calculated pulse count (see design example on page 163).

Stroke $< 2 \cdot$ runner block length B_1 (short stroke)

- Apply the minimum quantity according to Table 8 per lube port until the relubrication interval as specified (in Fig. 10) has been reached. Calculate the required pulse count and lubricant cycle time in the same way as for relubrication (normal stroke).
- At each lubrication cycle the runner block should be traversed through a lubricating stroke of $3 \cdot$ runner block length B_1 . In any case, the lubricating stroke must be at least the length of the runner block. If the largest possible lubricating stroke is smaller than the runner block length B_1 , lubricant must be applied to the guide rail. Please consult us for details.

Please also read the notes on relubrication on page 158 of this catalog!

Size	Relubrication (normal stroke)
	cm ³
25	0.8
35	0.9
45	1.0
55	1.4
65	2.7
55/85	1.8
65/100	3.2
100	15.0
125	as shown in Fig. 8

Table 7

Please also read the notes on relubrication on page 158 of this catalog!

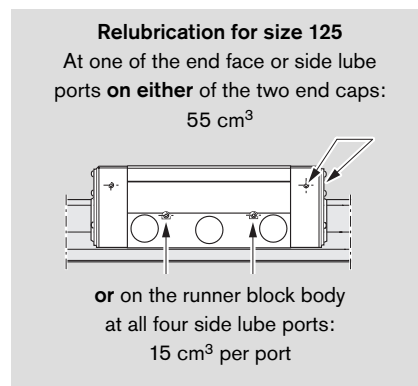

Fig. 8

Size	Relubrication (short stroke) per port	
	1st end cm ³	2nd end cm ³
25	0.8	0.8
35	0.9	0.9
45	1.0	1.0
55	1.4	1.4
65	2.7	2.7
55/85	1.8	1.8
65/100	3.2	3.2
100	15.0	15.0
125	Side ports as shown in Fig. 9	

Table 8

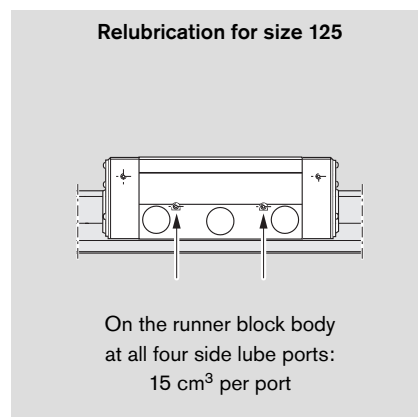
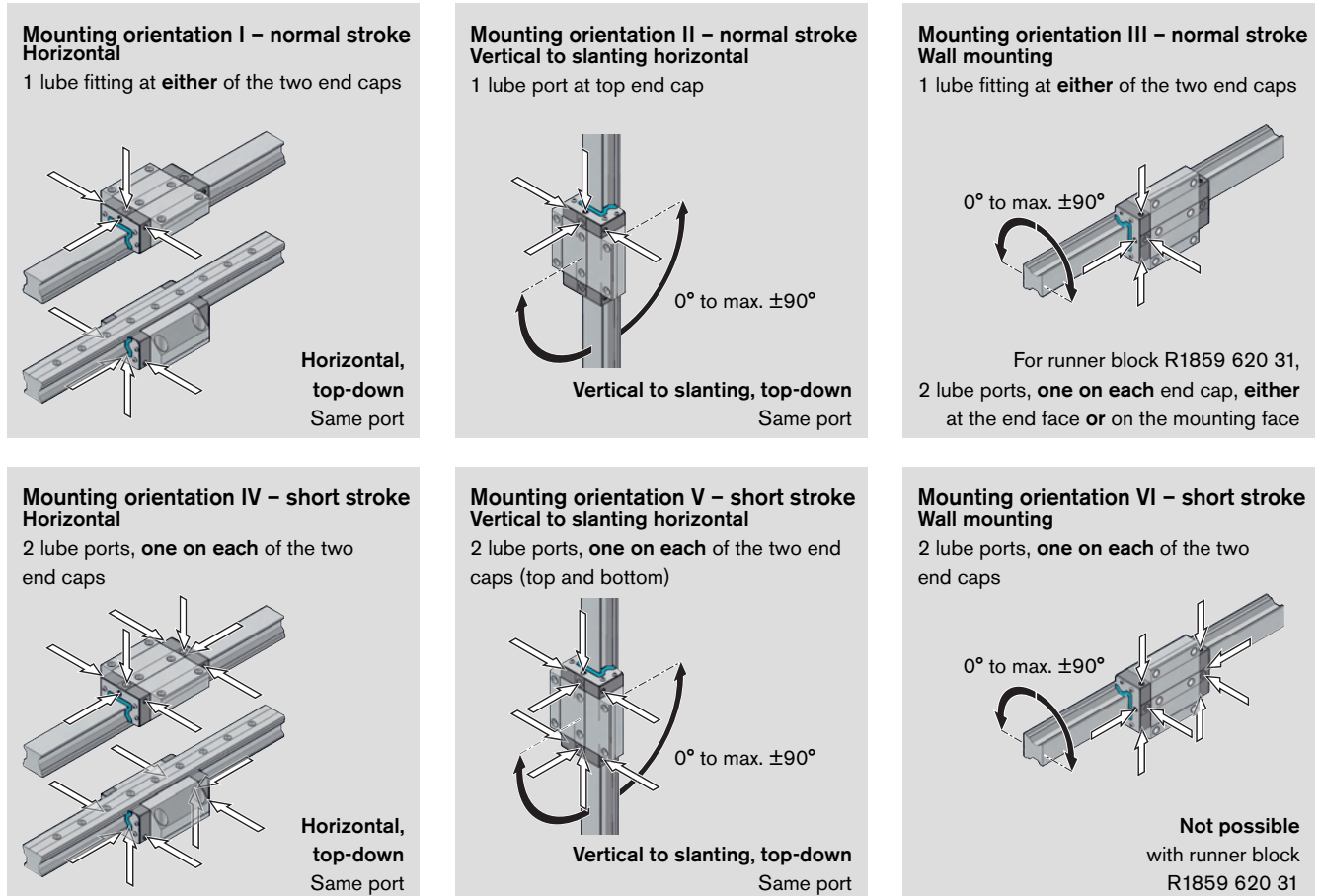

Fig. 9

Lubrication and Maintenance

Lubrication

Liquid grease lubrication via single-line piston distributor systems (continued)



Smallest permissible piston distributor sizes for liquid grease lubrication through single-line centralized systems¹⁾

Runner blocks		Smallest permissible piston distributor size (↔ minimum pulse quantity) per lube port (cm ³) for liquid grease, NLGI class 00								
		Size								
Part numbers	Mounting orientations	25	35	45	55	65	55/85	65/100	100	125
R18.. ... 10 or ... 60 or	Horizontal I, IV	0.06	0.1	0.1	0.1	0.2	0.1	0.2	0.3	0.3
R18.. ... 13 or ... 63 or	Vertical II, V	0.06	0.1	0.1	0.1	0.2	0.1	0.2	0.3	0.3
R18.. ... 16 or ... 66	Wall mounting III, VI	0.06	0.1	0.1	0.1	0.2	0.1	0.2	0.3 (2x) ²⁾	0.3 (2x) ²⁾³⁾
R18.. ... 18 or ... 68	Wall mounting III, VI ²⁾	–	0.06	0.06	0.06	–	–	–	–	–
R1859 620 31	Wall mounting III	–	–	–	–	0.1	–	–	–	–

Table 9

1) Applies under the following conditions:

- Dynalub 520 (or alternatively Castrol Longtime PD 00) and piston distributors from Vogel
- Lube ducts must be filled
- Ambient temperature T = 20 – 30 °C

2) Sizes 100 and 125: Either two pulses in short succession or two metering valves each delivering one pulse simultaneously

3) Size 125: 0.3 cm³ per port when all four ports in the runner block body are used

Lubrication and Maintenance

Lubrication

Liquid grease lubrication via single-line piston distributor systems (continued)

Load-dependent relubrication intervals for liquid grease lubrication via single-line piston distributor systems (“dry axes”)

Sizes 25 to 125

The following conditions apply:

- Liquid grease Dynalub 520 or alternatively Castrol Longtime PD 00
- Maximum speed: $v_{\max} = 2 \text{ m/s}$
- No exposure to metalworking fluids
- Standard seals
- Ambient temperature: $T = 20 - 30^\circ\text{C}$

Key to graph

- s = relubrication interval expressed as travel (km)
 C = dynamic load capacity (N)
 F = equivalent dynamic load (N)

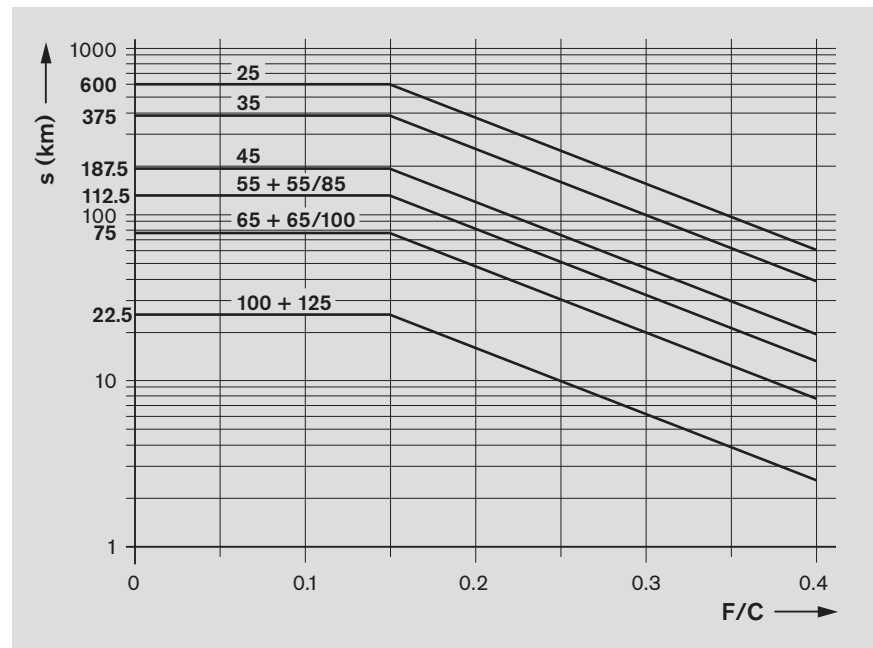

Fig. 10

For relubrication intervals in applications involving exposure to metalworking fluids, please consult us.

Without taking distance traveled into account

Assume 3 to 4 pulses per hour as a guide value for relubrication.

Notes

The load ratio F/C is the quotient of the equivalent dynamic load on the bearing F (making allowance for a preload of 8% C or 13% C) divided by the dynamic load capacity C (see “General Technical Data and Calculations”).

⚠ If other lubricants are used, this may lead to a reduction in the relubrication intervals, the achievable travel in short-stroke applications, and the load capacities. Possible chemical interactions between the plastic materials, lubricants and preservative oils must also be taken into account. In addition, the suitability of the lubricant for use in single-line centralized lubrication systems must be ensured.

⚠ Do not use greases containing solid particles (e.g., graphite or MoS_2)!

⚠ If the system is to be exposed to metalworking fluids, always apply 2 to 5 lubricant pulses at the beginning or when the system has been at a standstill for a longer period. If possible, apply lubricant while the system is in motion. Carry out cleaning and lubricating cycles (see “Maintenance”).

⚠ If the application conditions involve dirt, vibrations, impacts, etc. we recommend shortening the relubrication intervals accordingly. Even under normal operating conditions, the system must be relubricated at the latest after 2 years due to aging of the grease.

If your application involves more demanding environmental requirements (such as clean room, vacuum, food industry environment, increased exposure to fluids or aggressive media, extreme temperatures), please consult us. These situations must be investigated on a case by case basis and may require the use of a special lubricant. Be sure to have all the information concerning your application at hand when contacting us.

⚠ Switching from grease to oil lubrication while the system is in service is not possible as the lubrication ducts are already filled with grease, and oil will not be able to pass through them.

We recommend using piston distributors from Vogel. These should be installed as close as possible to the lube ports of the runner blocks.

Long lines and small line diameters should be avoided, and the lines should be laid on an upward slant.

A selection of possible lube fittings is given in the section “General Accessories – Runner Blocks” (for more information, you should also consult the manufacturer of your lubrication system).

If other consumers are connected to the single-line centralized lubrication system, the weakest link in the chain will determine the lubrication cycle time.

Lubrication and Maintenance

Lubrication

Oil lubrication via single-line piston distributor systems

Oil lubricant

We recommend using **Shell Tonna S 220** with the following properties:

- Special demulsifying oil CLP or CGLP to DIN 51517-3 for machine bed tracks and tool guides
- A blend of highly refined mineral oils and additives
- Can be used even when mixed with significant quantities of metalworking fluids

Please also read the notes on page 162 of this catalog!

Initial lubrication of the runner blocks (basic lubrication)

We recommend applying initial lubrication with a manual grease gun before connecting the equipment to the centralized lubrication system.

Stroke $\geq 2 \cdot$ runner block length B_1 (normal stroke)

- For initial lubrication, mount one lube fitting per runner block, at either of the two end caps!

Initial lubrication is applied in two partial quantities as specified in table 10:

1. Apply the first of the oil quantities as specified in table 10 to the runner block.
2. Slide the runner block back and forth over at least three times the block length (size 125: at least 300 mm) for three full cycles.
3. Repeat steps 1. and 2.
4. Check whether a film of lubricant is visible on the guide rail.

Stroke $< 2 \cdot$ runner block length B_1 (short stroke)

- Install and lubricate two lube fittings per runner block, one on each of the two end caps!

Initial lubrication is applied in two partial quantities per lube fitting as specified in table 11:

1. Apply the first of the oil quantities as specified in table 11 to each of the lube fittings on the runner block.
2. to 4. Repeat the procedure as for initial lubrication (normal stroke).

Size	Initial lubrication (normal stroke) Partial quantity cm ³
25	1.2 (2x)
35	1.3 (2x)
45	1.5 (2x)
55	2.0 (2x)
65	4.0 (2x)
55/85	2.7 (2x)
65/100	4.8 (2x)
100	11.0 (2x)
125	as shown in Fig. 11

Table 10

Size	Initial lubrication (short stroke) Partial quantity per port	
	1st end cm ³	2nd end cm ³
25	1.2 (2x)	1.2 (2x)
35	1.3 (2x)	1.3 (2x)
45	1.5 (2x)	1.5 (2x)
55	2.0 (2x)	2.0 (2x)
65	4.0 (2x)	4.0 (2x)
55/85	2.7 (2x)	2.7 (2x)
65/100	4.8 (2x)	4.8 (2x)
100	11.0 (2x)	11.0 (2x)
125	Lube ports 1st end, 2nd end and sides as shown in Fig. 12	

Table 11

If initial lubrication is nevertheless carried out via the centralized lubrication system, it is essential that all lines and piston distributors should be filled. The pulse count can then be calculated from the partial quantities and the piston distributor size according to Table 14.

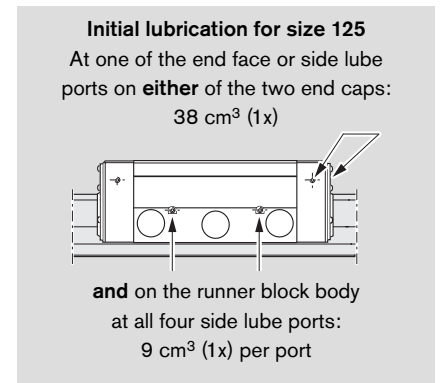

Fig. 11

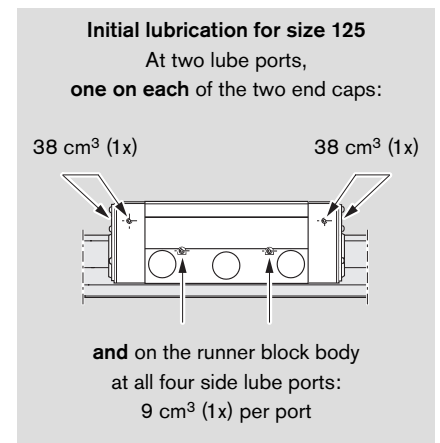

Fig. 12

Lubrication and Maintenance

Lubrication

Oil lubrication via single-line piston distributor systems (continued)

Relubrication of runner blocks

Stroke $\geq 2 \cdot$ runner block length B_1 (normal stroke)

- Apply the minimum quantity according to Table 12 to the lube port until the relubrication interval as specified (in Fig. 15) has been reached.

Notes

The required pulse count is the quotient (as a whole number) of the minimum relubrication quantity according to Table 12 and the smallest permissible piston distributor size (i.e. the minimum pulse quantity) according to Table 14. The smallest permissible piston distributor size also depends on the mounting orientation.

The lubricant cycle time can then be obtained by dividing the relubrication interval (according to Fig. 15) by the calculated pulse count.

Stroke $< 2 \cdot$ runner block length B_1 (short stroke)

- Apply the minimum quantity according to Table 13 per lube port until the relubrication interval as specified (in Fig. 15) has been reached. Calculate the required pulse count and lubricant cycle time in the same way as for relubrication (normal stroke).
- At each lubrication cycle the runner block should be traversed through a lubricating stroke of $3 \cdot$ runner block length B_1 . In any case, the lubricating stroke must be at least the length of the runner block. If the largest possible lubricating stroke is smaller than the runner block length B_1 , lubricant must be applied to the guide rail. Please consult us for details.

Please also read the notes on relubrication on page 162 of this catalog!

Size	Relubrication (normal stroke)	
	cm ³	
25	1.2	
35	1.3	
45	1.5	
55	2.0	
65	4.0	
55/85	2.7	
65/100	4.8	
100	11.0	
125	as shown in Fig. 13	

Table 12

Please also read the notes on relubrication on page 162 of this catalog!

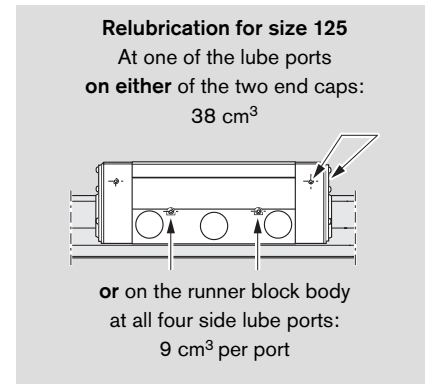

Fig. 13

Size	Relubrication (short stroke) per port	
	1st end cm ³	2nd end cm ³
25	1.2	1.2
35	1.3	1.3
45	1.5	1.5
55	2.0	2.0
65	4.0	4.0
55/85	2.7	2.7
65/100	4.8	4.8
100	11.0	11.0
125	Side ports as shown in Fig. 14	

Table 13

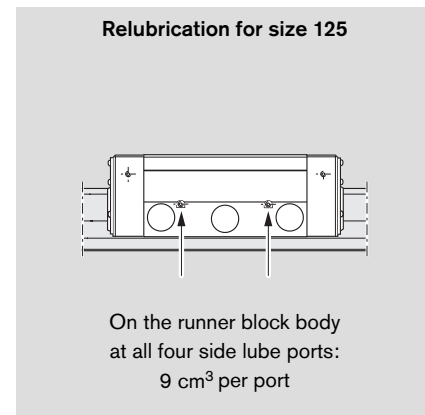
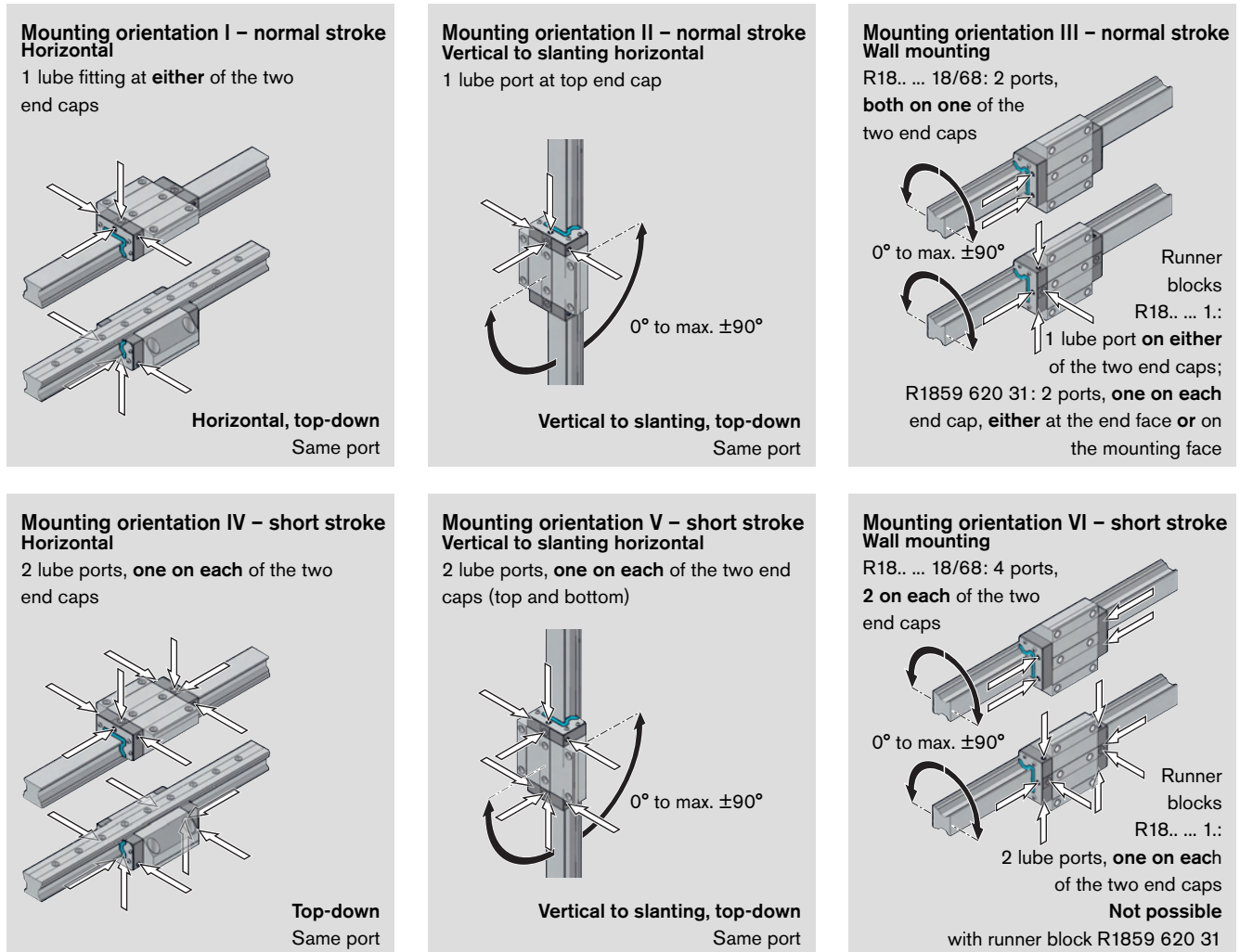

Fig. 14

Lubrication and Maintenance

Lubrication

Oil lubrication via single-line piston distributor systems (continued)

Smallest permissible piston distributor sizes for oil lubrication via single-line centralized systems¹⁾

Runner blocks		Smallest permissible piston distributor size (⇔ minimum pulse quantity) per lube port (cm ³) at oil viscosity 220 mm ² /s								
		Size								
Part numbers	Mounting orientations	25	35	45	55	65	55/85	65/100	100	125
R18.. ... 10 or ... 60 or	Horizontal I, IV	0.06	0.10	0.10	0.16	0.2	0.6	0.6	1.5	1.5
R18.. ... 13 or ... 63 or	Vertical II, V	0.06	0.10	0.10	0.16	0.2	0.6	0.6	1.5	1.5
R18.. ... 16 or ... 66	Wall mounting III, VI ²⁾	0.10	0.20	0.40	0.40	0.6	1.0	1.5	1.5 (3x) ³⁾	1.5 (3x) ³⁾⁴⁾
R18.. ... 17 or ... 67	Horizontal I, IV	–	0.06	0.06	0.10	–	–	–	–	–
	Vertical II, V	–	0.06	0.06	0.10	–	–	–	–	–
	Wall mounting III, VI ²⁾	–	0.06	0.10	0.16	–	–	–	–	–
R18.. ... 18 or ... 68	Wall mounting III, VI ²⁾	–	0.06	0.06	0.10	–	–	–	–	–
R1859 620 31	Wall mounting III	–	–	–	–	0.1	–	–	–	–

Table 14

1) Applies under the following conditions: Lube oil Shell Tonna S 220 using piston distributors from Vogel

2) Please note the varying **suitability of the runner blocks for the mounting orientations wall mounting III, VI:**

+++ runner blocks R18.. ... 18 or ... 68

++ runner blocks R18.. ... 17 or ... 67

+ runner blocks R18.. ... 10/13/16 or ... 60/63/66

3) Sizes 100 and 125: Either three pulses in short succession or three metering valves delivering one pulse simultaneously

4) Size 125: 1.5 cm³ per port when all four ports in the runner block body are used

Lubrication and Maintenance

Lubrication

Oil lubrication via single-line piston distributor systems (continued)

Load-dependent relubrication intervals for oil lubrication via single-line piston distributor systems ("dry axes")

Sizes 25 to 125

The following conditions apply:

- Shell Tonna S 220
- Maximum speed:
 $v_{\max} = 2 \text{ m/s}$
- No exposure to metalworking fluids
- Standard seals
- Ambient temperature:
 $T = 20 - 30^\circ\text{C}$

Key to graph

- s = relubrication interval
expressed as travel (km)
- C = dynamic load capacity (N)
- F = equivalent dynamic load (N)

Notes

The load ratio F/C is the quotient of the equivalent dynamic load on the bearing F (making allowance for a preload of 8% C or 13% C) divided by the dynamic load capacity C (see "General Technical Data and Calculations").

⚠ If other lubricants are used, this may lead to a reduction in the relubrication intervals, the achievable travel in short-stroke applications, and the load capacities. Possible chemical interactions between the plastic materials, lubricants and preservative oils must also be taken into account. In addition, the suitability of the lubricant for use in single-line centralized lubrication systems must be ensured.

⚠ Do not use greases containing solid particles (e.g., graphite or MoS_2)!

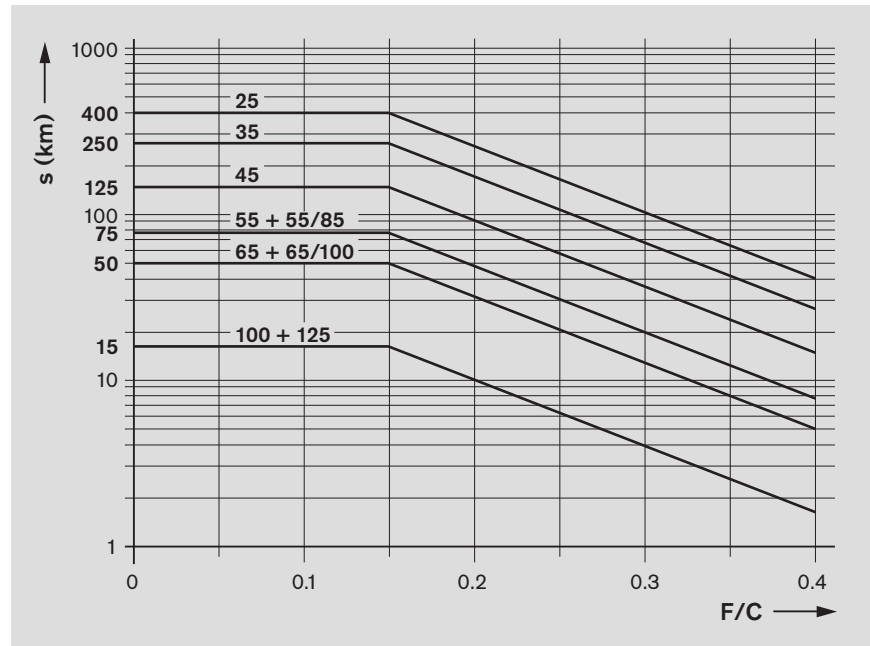

Fig. 15

For relubrication intervals in applications involving exposure to metalworking fluids, please consult us.

Without taking distance traveled into account

Assume 3 to 4 pulses per hour as a guide value for relubrication.

⚠ If the system is to be exposed to metalworking fluids, always apply 2 to 5 lubricant pulses at the beginning or when the system has been at a standstill for a longer period. If possible, apply lubricant while the system is in motion. Carry out cleaning and lubricating cycles (see "Maintenance").

⚠ If the application conditions involve dirt, vibrations, impacts, etc. we recommend shortening the relubrication intervals accordingly.

If your application involves more demanding environmental requirements (such as clean room, vacuum, food industry environment, increased exposure to fluids or aggressive media, extreme temperatures), please consult us. These situations must be investigated on a case by case basis and may require the use of a special lubricant. Be sure to have all the information concerning your application at hand when contacting us.

⚠ Switching from grease to oil lubrication while the system is in service is not possible as the lubrication ducts are already filled with grease, and oil will not be able to pass through them.

We recommend using piston distributors from Vogel. These should be installed as close as possible to the lube ports of the runner blocks. Long lines and small line diameters should be avoided, and the lines should be laid on an upward slant.

A selection of possible lube fittings is given in the section "General Accessories – Runner Blocks" (for more information, you should also consult the manufacturer of your lubrication system).

If other consumers are connected to the single-line centralized lubrication system, the weakest link in the chain will determine the lubrication cycle time.

Lubrication and Maintenance

Lubrication

Design calculation example for lubrication of a typical 2-axis application with centralized lubrication

X-axis

Component or parameter	Given data
Runner block	Size 45; 4 blocks; C = 92,300 N; part numbers: R1851 423 10 (catalog page 38)
Guide rail	Size 45; 2 rails; L = 1,500 mm; part numbers: R1805 463 61 (catalog page 64)
Equivalent dynamic load on bearing	F = 20,768 N (per runner block) taking into account the preload (in this case 8% C)
Stroke	500 mm
Average speed	$v_m = 1$ m/s
Temperature	20 to 30°C
Mounting orientation	Horizontal
Lubrication	Single-line centralized lubrication system for all axes with liquid grease Dynalub 520
Exposure to contaminants	No exposure to fluids, chips, dust

Design variables	Design input (per runner block)	Information sources
1. Normal or short stroke?	Normal stroke: Stroke $\geq 2 \cdot$ runner block length B_1 $500 \text{ mm} \geq 2 \cdot 101.5 \text{ mm} ?$ $500 \text{ mm} \geq 203 \text{ mm}$ i.e. normal stroke	– Normal stroke formula from catalog page 155, B_1 from catalog page 39
2. Initial lubrication quantity	Initial lubrication quantity: 1.0 cm^3 (3x)	– Initial lubrication quantity from Table 5
3. Relubrication quantity	Relubrication quantity: 1.0 cm^3	– Relubrication quantity from Table 7
4. Mounting orientation	Mounting orientation I – normal stroke (horizontal)	– Mounting orientation from catalog page 157
5. Piston distributor size	Permissible piston distributor size: 0.1 cm^3	– Piston distributor size from Table 9 For size 45, mounting orientation I
6. Pulse count	$\text{Pulse count} = \frac{1.0 \text{ cm}^3}{0.1 \text{ cm}^3} = 10$	– Pulse count = $= \frac{\text{relubrication quantity}}{\text{perm. piston distributor size}}$
7. Load ratio	$\text{Load ratio} = \frac{20,768 \text{ N}}{92,300 \text{ N}} = 0.225$	– Load ratio = $\frac{F}{C}$ F and C from given data
8. Relubrication interval	Relubrication interval: 90 km	– Relubrication interval from Table 10: – Curve size 45 at load ratio 0.22
9. Lubrication cycle	$\text{Lubrication cycle} = \frac{90 \text{ km}}{10} = 9 \text{ km}$	– Lube cycle = $\frac{\text{relubrication interval}}{\text{pulse count}}$
Interim result (X-axis)	For the X-axis, a minimum quantity of 0.1 cm^3 Dynalub 520 must be supplied to each runner block every 9 km.	

Lubrication and Maintenance

Lubrication

Y-axis

Component or parameter	Given data
Runner block	Size 35; 4 blocks; C = 56,300 N; part numbers: R1851 323 10 (catalog page 38)
Guide rail	Size 35; 2 rails; L = 1,000 mm; part numbers: R1805 333 61
Equivalent dynamic load on bearing	F = 8,445 N (per runner block) taking into account the preload (in this case 8% C)
Stroke	50 mm
Average speed	$v_m = 1$ m/s
Temperature	20 to 30°C
Mounting orientation	Vertical
Lubrication	Single-line centralized lubrication system for all axes with liquid grease Dynalub 520
Exposure to contaminants	No exposure to fluids, chips, dust

Design variables

Design input (per runner block)

Information sources

1. Normal or short stroke?	Normal stroke: Stroke $\geq 2 \cdot$ runner block length B_1 $50 \text{ mm} \geq 2 \cdot 79.6 \text{ mm} ?$ $50 \text{ mm} < 159.6 \text{ mm}$ i.e. short stroke	– Normal stroke formula from catalog page 155, B_1 from catalog page 39
2. Initial lubrication quantity	2 lube ports, initial lubrication quantity per lube port: 0.9 cm^3 (3x)	– Initial lubrication quantity from Table 5
3. Relubrication quantity	2 lube ports, relubrication quantity per port: 0.9 cm^3	– Relubrication quantity from Table 7
4. Mounting orientation	Mounting orientation V – short stroke (vertical)	– Mounting orientation from catalog page 157
5. Piston distributor size	Permissible piston distributor size: 0.1 cm^3	– Piston distributor size from Table 9 for size 35, mounting orientation V
6. Pulse count	Pulse count = $\frac{0.9 \text{ cm}^3}{0.1 \text{ cm}^3} = 9$	– Formula as for X-axis
7. Load ratio	Load ratio = $\frac{8,445 \text{ N}}{56,300 \text{ N}} = 0.15$	– Formula as for X-axis, F and C from given data
8. Relubrication interval	Relubrication interval: 375 km	– Relubrication interval from Fig. 10: – Curve size 35 at load ratio 0.15
9. Lubrication cycle	Lubrication cycle = $\frac{375 \text{ km}}{9} = 42 \text{ km}$	– Formula as for X-axis

Interim result (Y-axis)

For the Y-axis, a minimum quantity of 0.1 cm^3 Dynalub 520 must be supplied to each runner block every 42 km.

End result (two-axis lubrication)

Since both the axes in this example are supplied by a single-line centralized lubrication system, the X-axis with its smaller lube cycle (9 km) determines the overall cycle of the system, i.e. the Y-axis will also be lubricated every 9 km.

The number of ports and the minimum lubricant quantities determined for each axis remain the same.

Lubrication and Maintenance

Lubrication

Lubrication from above

Standard runner blocks with open lube ports for lubrication from above

The following new standard runner blocks have lube ports opened at the top:

R18... .. 16 or ... 66

R18... .. 17 or ... 67

In the new standard runner blocks for lubrication from above the top lube holes have already been opened, but they are closed with screws for shipment.

In the high runner blocks S.H, slimline ... high, the vertical clearance between the end caps and an attachment mounting surface with integrated lube adapters has been designed for ease of maintenance (see Fig. B).

Remove screw (1) from the lube hole (3).

Insert O-ring (2) in the recess (O-ring is supplied with the runner block).

Subsequent opening of a lube hole at the top for standard runner blocks F.S and S.H and for heavy duty runner blocks

If a lube hole is to be opened up at the top of standard or heavy duty runner blocks, the following points should be noted:

⚠ In the O-ring recess there is a further pre-formed small recess (5). Do not use a drill to open this. Risk of contamination!

- Heat up a pointed metal punch (4) with diameter of 1.5 mm.
- Carefully punch through the recess (5) to open the lube hole.
- Do not exceed the permissible depth T_{max} as specified in the table!
- Insert O-ring (2) in the recess (O-ring is **not** supplied with the runner block).

For subsequent lubrication from above of high runner blocks S.H, use a lube adapter (not included in supply scope; please consult us).

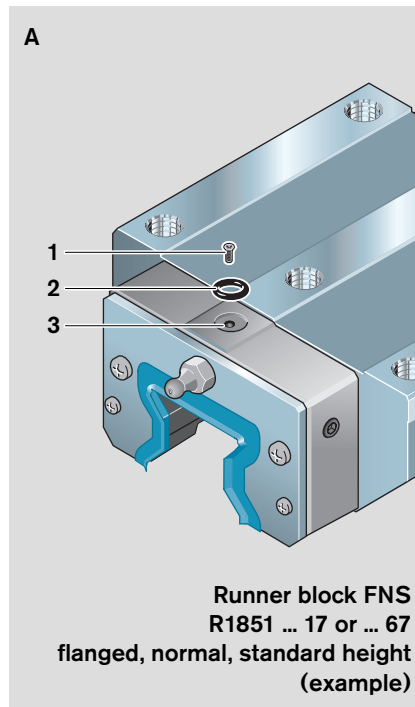

Runner block FNS
R1851 ... 17 or ... 67
flanged, normal, standard height
(example)

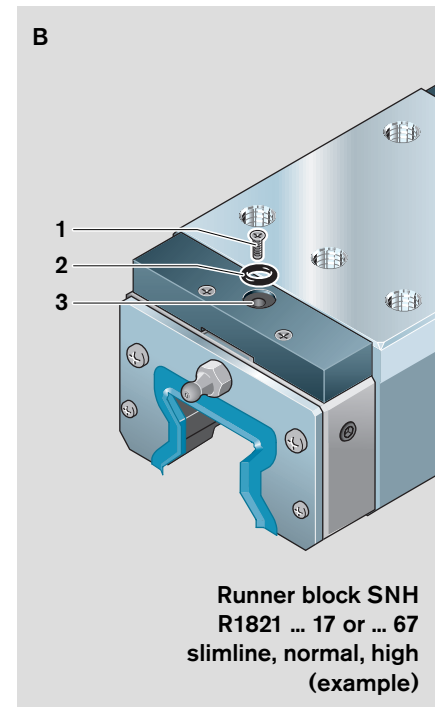

Runner block SNH
R1821 ... 17 or ... 67
slimline, normal, high
(example)

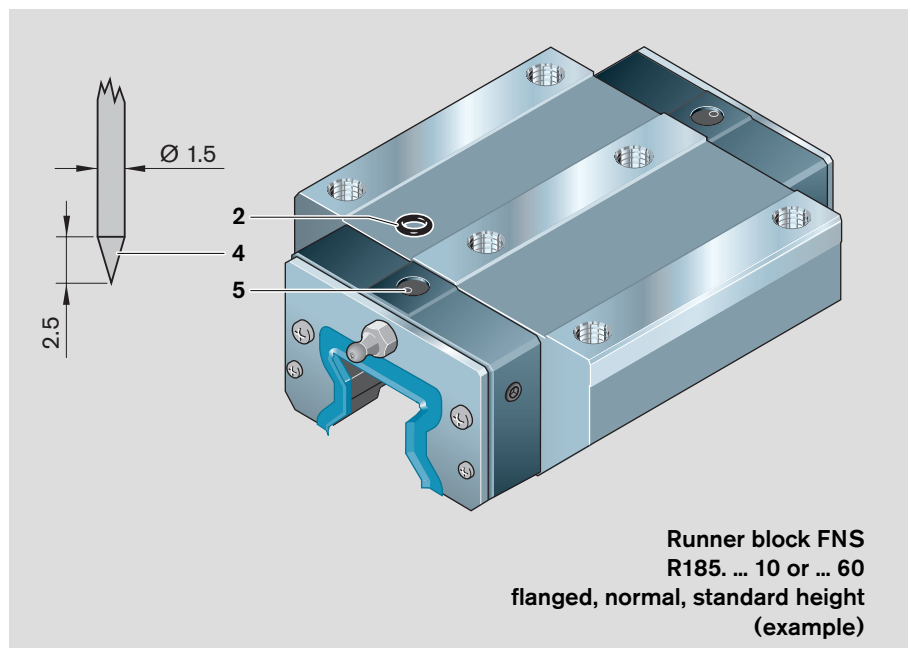

Runner block FNS
R185... 10 or ... 60
flanged, normal, standard height
(example)

Size	Lube hole at top: Maximum permissible depth for punching open T_{max} (mm)
25	4
35	5
45	5
55	5
65	5
100	5

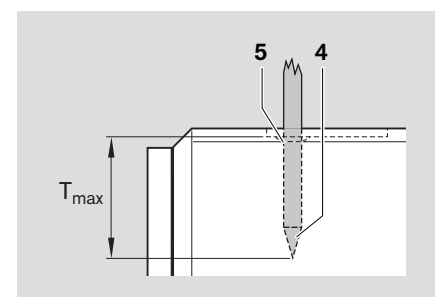

Lubrication and Maintenance

Maintenance

Cleaning cycle

Dirt can settle and encrust on guide rails, especially when these are not enclosed.

To ensure that seals and cover strips retain their functionality, this dirt must be removed at regular intervals.

It is advisable to run the machine through at least one full cleaning cycle over the entire installed rail length every 8 hours. Depending on the amount of soiling and on the coolant used, more frequent cleaning may be required.

Before shutting down the machine, always run two cleaning cycles over the entire installed rail length, followed by at least two lubrication cycles over the entire installed rail length.

Checking accessories

All accessories used for scraping or wiping the guide rails must be checked at regular intervals.

In environments with heavy soiling, it is advisable to replace all the parts in the soiled area.

We recommend checking the accessories at least once a year.

Bosch Rexroth Corporation
Linear Motion and
Assembly Technologies
14001 South Lakes Drive
Charlotte, NC 28273
Telephone (800) 438-5983
Facsimile (704) 583-0523
www.boschrexroth-us.com

Bosch Rexroth Corporation
Corporate Headquarters
5150 Prairie Stone Parkway
Hoffman Estates, IL 60192-3707
Telephone (847) 645-3600
Facsimile (847) 645-6201

Bosch Rexroth Corporation
Industrial Hydraulics
2315 City Line Road
Bethlehem, PA 18017-2131
Telephone (610) 694-8300
Facsimile (610) 694-8467

Bosch Rexroth Corporation
Electric Drives and Controls
5150 Prairie Stone Parkway
Hoffman Estates, IL 60192-3707
Telephone (847) 645-3600
Facsimile (847) 645-6201

Bosch Rexroth Corporation
Pneumatics
1953 Mercer Road
Lexington, KY 40511-1021
Telephone (859) 254-8031
Facsimile (859) 281-3491

Bosch Rexroth Corporation
Mobile Hydraulics
1700 Old Mansfield Road
Wooster, OH 44691-0394
Telephone (330) 263-3300
Facsimile (330) 263-3333